

T40-180SLP 75 V R-Series Telescopic Handler

Telescopic Specifications

Performance

Rated capacity	4000 kg
Capacity (at max. height on tyres)	1000 kg
Capacity at max. height on stabilizers	2500 kg
Capacity at max. reach on stabilizers	500 kg
Lifting height	16200.0 mm
Lifting height on stabilizers	17466.0 mm
Tilt Breakout force	12300 daN
Drawbar pull (24" tyres)	4500 daN
Max. gradeability (24" tyres)	25.0°
Max. reach	13680.0 mm
Lifting height on stabilizers (24" tyres)	17466.0 mm
Max. reach on stabilizers (24" tyres)	13680.0 mm

Cycle times

Boom raising	16.0 s
Boom lowering	10.0 s
Boom extension	36.5 s
Boom retraction	22.0 s
Crowding	6.0 s
Dumping	5.0 s

Weights

Unladen weight (24" tyres)	10290 kg
----------------------------	----------

Engine

Make / Model	Bobcat D34
Fuel	DIESEL
Rated power (ISO 14396)	55.0 kW
Rated speed	2400.0 RPM
Maximum torque at 1400 rpm	360.0 Nm
Number of cylinders	4.0
Displacement	3.41 L

Hydraulic system

Pump type	Gear pump with LS valve
Pump capacity	80.00 L/min
Relief valve pressure setting	250.00 bar
Control valve type	Open center with flow sharing & flow compensators technology

Drive system

Transmission	Hydrostatic with electronic regulation
Main Drive	Hydrostatic motor

Traction

Standard Tyres	400/80-24 / 20PR TM R4
Max speed - rabbit mode (24" / 20")	24 kph

Brakes

Engine Braking	Hydrostatic
Parking and Emergency brake	Passive brake
Service Brake	Oil immersed discs

Steering

Steering Mode	2 wheel steering / 4 wheel steering / Crab-steering
---------------	---

Fluid Capacities

Fuel tank	145.00 L
Hydraulic tank	76.00 L
Hydraulic system	173.00 L

Environmental

Operator noise level (LpA) (EN 12053)	75 dB(A)
Level of acoustic power (LwA)	104 dB(A)
Whole body vibration (EN 13059)	1.20 ms ⁻²

Dimensions

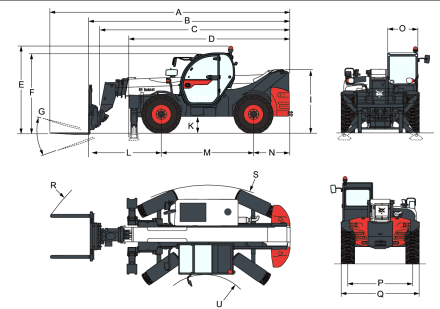

Values marked with * - 24" tyres

(A)	7425.0 mm	(L)	2263.0 mm
(B)	6220.0 mm	(M)	2850.0 mm
(C)	5821.0 mm	(N)	1107.0 mm
(D*)	4950.0 mm	(O)	930.0 mm
(E*)	2673.0 mm	(P)	1992.0 mm
(F*)	2520.0 mm	(Q)	2418.0 mm
(G)	124.0°	(R*)	5840.0 mm
(I*)	1956.0 mm	(S*)	4150.0 mm
(K*)	509.0 mm	(U*)	1519.0 mm

Load Charts

Load Charts

