

Performance

Tipping load - Straight - Bucket	1265 kg
Tipping load - Straight - Forks	872 kg
Tipping load - Articulated - Bucket	1051 kg
Tipping load - Articulated - Forks	724 kg
Rated Operating Capacity - Straight - Bucket	633 kg
Rated Operating Capacity - Straight - Forks	436 kg
Rated Operating Capacity - Articulated - Bucket	525 kg
Rated Operating Capacity - Articulated - Forks	362 kg
Lift Capacity	1116 kg
Breakout Force - Boom	1047 kg

Engine

Make / Mode	KUBOTA / D1305-E4B-BC-1
Fuel	DIESEL
Cooling	53% PROPYLENE GLYCOL / 47% WATER MIXTURE
Power at 2600 RPM (ISO 14396)	18.2 kW
Torque at 1700 RPM (ISO 14396)	81.3 Nm
Number of cylinders	3 IN-LINE
Displacement	1.26 L

Weight

Operating weight	1719 kg
Shipping weight	1540 kg

Hydraulic System

System Relief	20.0 MPa
Implement Pump	ENGINE DRIVEN GEAR TYPE
Implement Pump Capacity	45.80 L/min
Main Filter	REPLACEABLE 16(c) ≥ 75 ISO 4572, SPIN ON WITH O-RING, 0.34 MPa [50 psi] BYPASS
Tank Breather Filter	NON-REPLACEABLE 10 MICRON, THREAD-ON CAP
Control Valve	MANUALLY OPERATED SERIES TYPE (LIFT & TILT FUNCTIONS) WITH FLOAT DETENT ON LIFT. E/H OPERATED PARALLEL TYPE (AUX & TELESCOPIC FUNCTIONS)
Hydraulic Fluid	PREMIUM GRADE, ANTI WEAR, MULTI VISCOSITY ISO VG46, PETROLEUM BASED

Fluid Capacities

Cooling System	5.70 L
Fuel tank	36.20 L
Engine Oil	3.80 L
Hydraulic and Hydrostatic System	18.50 L

Drive System

Transmission	4 Wheel Drive with automatic drive modes, Optional Traction assist function
--------------	---

Electrical

Alternator	90 AMP VENTILATED
Battery	12 VOLT BCI GROUP 26 540 AMPS COLD CRANKING CAPACITY AT 0 F (-18 C) 80 MINUTE RESERVE CAPACITY
Starter	12 V GEAR TYPE 2.0 kW [2.68 hp]
Ignition Switch	ACTIVATES STARTER AND INSTRUMENTATION

Cycle times

Raising time	2.4 s
Lowering time	2.0 s
Dump time	1.7 s
Rollback time	1.2 s

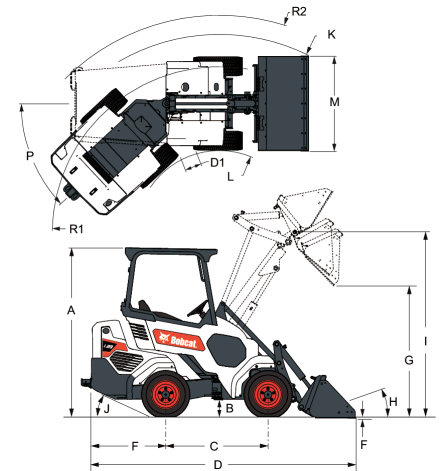
Dimensions

(A)	1983.7 mm	(J)	23.0°
(B)	139.1 mm	(K)	2339.2 mm
(C)	1200.0 mm	(L)	974.4 mm
(D)	3109.0 mm	(M)	1117.6 mm
(E)	19.5 mm	(O)	1180.7 mm
(G)	1654.8 mm	(P)	43.0°
(H)	30.0°	(Q)	40.0°
(I)	2169.2 mm		