

SECTION DRAWING

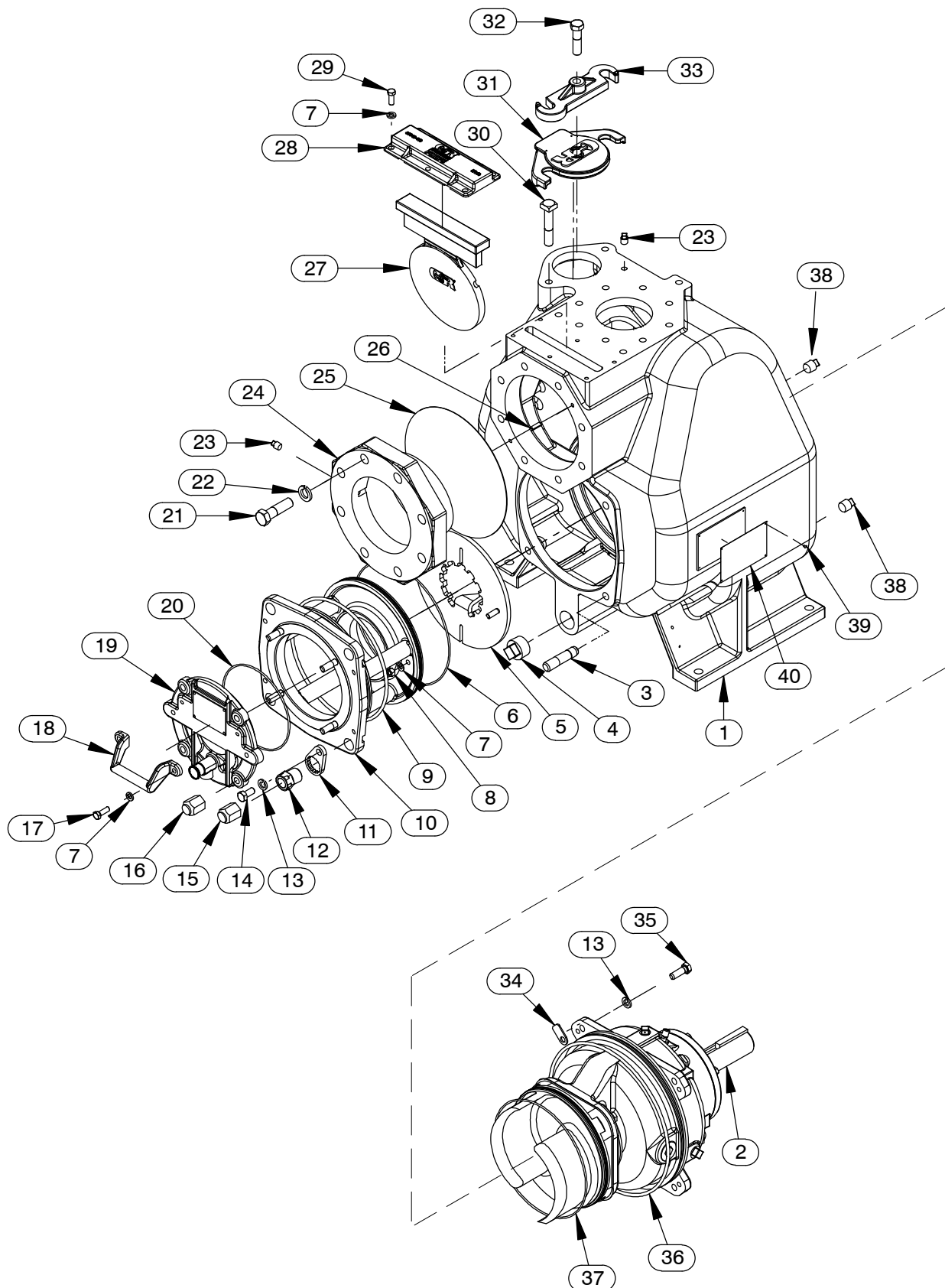

Figure 1. Pump Model V4A60-B (Including /WW)

PARTS LIST
Pump Model V4A60-B (Including /WW)
 (From S/N 1727335 Up)

If your pump serial number is followed by an "N", your pump is **NOT** a standard production model. Contact the Gorman-Rupp Company to verify part numbers.

ITEM NO.	PART NAME	PART NUMBER	QTY	ITEM NO.	PART NAME	PART NUMBER	QTY
1	PUMP CASING	SEE NOTE BELOW	1	39	DRIVE SCREW	BM#04-03 17000	4
2	REPAIR ROTATING ASSY:			40	NAMEPLATE BLANK	38819-002 13000	1
	-V4A60-B	44163-458	1	NOT SHOWN:			
	-V4A60-B /WW	44163-459	1		INSTRUCTION TAG	38817-023	1
3	STUD	C1213 15991	4		ULTRA V DECAL	38816-342	1
4	PIPE PLUG	P20 10009	1		G-R DECAL	GR-03	1
5 *	WEAR PLATE ASSY	46451-760 24150	1		DISCHARGE STICKER	6588BJ	1
6 *	O-RING	25152-273	1		FILL TO PRIME STICKER	6588AH	1
7	LOCK WASHER	J06 15991	10		SUCTION STICKER	6588AG	1
8	HEX NUT	D06 15991	2		WARNING DECAL	2613FE	1
9 *	O-RING	S1674	1		LUBRICATION DECAL	38817-084	1
10	BACK COVER ASSY	42111-461	1		ROTATION DECAL	2613M	1
11	LOCK COLLAR	38115-551 15001	4		INSTRUCTION TAG	38817-011	1
12	ADJUSTING SCREW	31871-070 1500G	4	OPTIONAL:			
13	LOCK WASHER	J08 15991	8		DISASSEMBLY TOOL	48711-020	1
14	HEX HEAD CAP SCREW	B0804 15991	4	FLAP VALVES:			
15	BACK COVER NUT	31871-073 15000	4	†	-FLUOROCARBON	46411-152 24010	1
16	BACK COVER NUT	31871-075 15000	4		-BUNA-N	46411-153 24010	1
17	HEX HEAD CAP SCREW	B0604-1/2 15991	2		-EPDM	46411-157 24010	1
18	HANDLE	12354 13010	1	FLANGE KITS:			
19	INSPECT COVER ASSY	42111-456	1		-4" NPT DISCH KIT	48213-125	1
	-WARNING PLATE	2613EV 13990	1		-6" X 4" ASA SUCTION/DISCHARGE		
	-DRIVE SCREW	BM#04-03 17000	4		SPOOL KIT	48213-147	1
	* -PRESS RELIEF VALVE	26662-005	1		-6" ASA SUCTION		
20 *	O-RING	S1472	1		SPOOL KIT	48213-146	1
21	HEX HEAD CAP SCREW	B1211 15991	8		-4" ASA DISCHARGE		
22	LOCK WASHER	J12 15991	8		SPOOL KIT	48213-126	1
23	PIPE PLUG	P04 15079	2		-6" X 4" METRIC SUCTION/DISCHARGE		
24	SUCTION FLANGE	38641-532 10000	1		SPOOL KIT	48213-127	1
25 *	GASKET	38683-660 19370	1		-6" METRIC SUCTION		
26	ROLL PIN	21154-229	2		SPOOL KIT	48213-148	1
27	FLAP VALVE ASSY	46411-151 24010	1		-4" METRIC DISCHARGE		
28	FLAP VALVE COVER	38346-619 17040	1		SPOOL KIT	48213-149	1
29	HEX HEAD CAP SCREW	B0604 15991	6	G-R HARD IRON PARTS:			
30	MACHINE BOLT	A1014 15991	2		-WEAR PLATE ASSY	46451-760 24160	1
31	FILL PORT COVER ASSY	42111-437	1	SST PARTS:			
	* -FILL PORT GASKET	50G 19210	1		-WEAR PLATE ASSY	46451-760 24170	1
	-WARNING PLATE	38816-097 13990	1	HI TEMP SHUT-DOWN KITS:			
	-DRIVE SCREW	BM#04-03 17000	2		-145°F	48313-186	1
32	HEX HEAD CAP SCREW	B1010S 15991	1		-130°F	48313-256	1
33	CLAMP BAR	38111-004 11010	1		-120°F	48313-257	1
34	SPACER	33221-022 17040	4	HIGH TEMP SHUT-DOWN THERMOSTAT KIT 145°F			
35	HEX HEAD CAP SCREW	B0806 15991	4		AIR RELEASE VALVES:		
36 *	O-RING	S1676	1		-10# COMP SPRING	GRP33-07A	1
37 *	O-RING	25152-273	1		-25# COMP SPRING	GRP33-07	1
38	PIPE PLUG	P08 15079	2		-80# COMP SPRING	GRP33-07B	1

* INDICATES PARTS RECOMMENDED FOR STOCK

☞ INCLUDED WITH REPAIR 46472-735 1
 PUMP CASING ASSY

† DUPONT VITON® OR EQUIVALENT

SECTION DRAWING

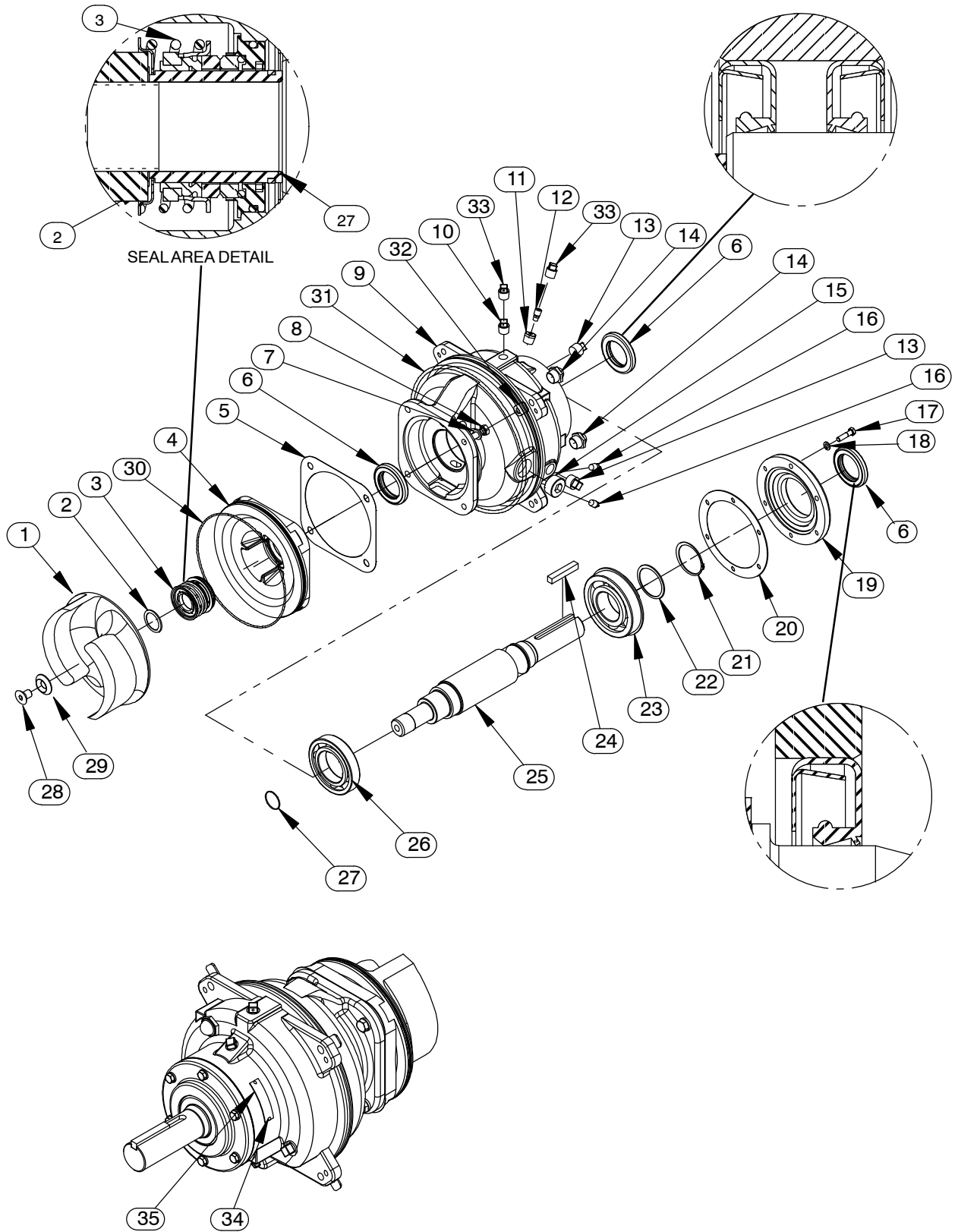

Figure 2. Repair Rotating Assemblies

PARTS LIST

Repair Rotating Assemblies

Note: Order the complete Repair Rotating Assembly from the Pump Model Assembly Parts List on page E-3. Rotating Assemblies for /WW models also include all standard parts listed below.

ITEM NO.	PART NAME	PART NUMBER	QTY
1	* IMPELLER	38615-104 11010	1
2	* ADJ SHIM SET	5091 17090	1
3	* CARTRIDGE SEAL ASSY	46513-154	1
4	SEAL PLATE	38272-360 10000	1
5	* GASKET	38687-059 20000	1
6	* OIL SEAL	S1907	3
7	LOCK WASHER	J08 15991	4
8	HEX HEAD CAP SCREW	B0806 15991	4
9	BEARING HOUSING	38251-521 10000	1
10	VENTED PIPE PLUG	4823A 15079	1
11	REDUCER PIPE BUSHING	AP0802 15079	1
12	AIR VENT	S1530	1
13	PIPE PLUG	P12 15079	2
14	SIGHT GAUGE	S1471	2
15	SOC HD PIPE PLUG	PC20 10009	1
16	PIPE PLUG	P04 15079	2
17	HEX HEAD CAP SCREW	B0606 15991	6
18	LOCK WASHER	J06 15991	6
19	BEARING CAP	38322-230 10000	1
20	* GASKET	38683-474 18000	1
21	RETAINING RING	S720	1
22	THRUST WASHER	31133-268 15000	1
23	* BALL BEARING	23287-014	1
24	* KEY	N0812 15990	1
25	* IMPELLER SHAFT	38514-828 16000	1
26	* BALL BEARING	23251-019	1
27	* O-RING	25154-026	REF
28	FLAT HEAD SOCKET SCREW	F1004S 1500G	1
29	IMPELLER WASHER	31167-029 16000	1
30	* O-RING	25152-273	1
31	* O-RING	S1676	1
32	SPACER	33221-022 17040	4
33	SHIPPING PLUG	11495B 15079	2
34	DRIVE SCREW	BM#04-03 17000	2
35	ASSEMBLY PLATE	2613GG 13990	1
NOT SHOWN:			
	INSTRUCTION TAG	6588U	1
	ROTATION DECAL	2613M	1
OPTIONAL:			
G-R HARD IRON PARTS:			
	-IMPELLER	38615-104 1102H	1
	-SEAL PLATE	38272-360 1102H	1
SST PARTS:			
	-IMPELLER	38615-104 17070	1
	-SEAL PLATE	38272-360 17070	1
	-IMPELLER SHAFT	38514-828 1706H	1
	-IMP CAPSCREW	F1004S 1704G	1
	-IMPELLER WASHER	31167-029 1706H	1
	-CART SEAL ASSY	46513-159	1

* INDICATES PARTS RECOMMENDED FOR STOCK