

ILLUSTRATION

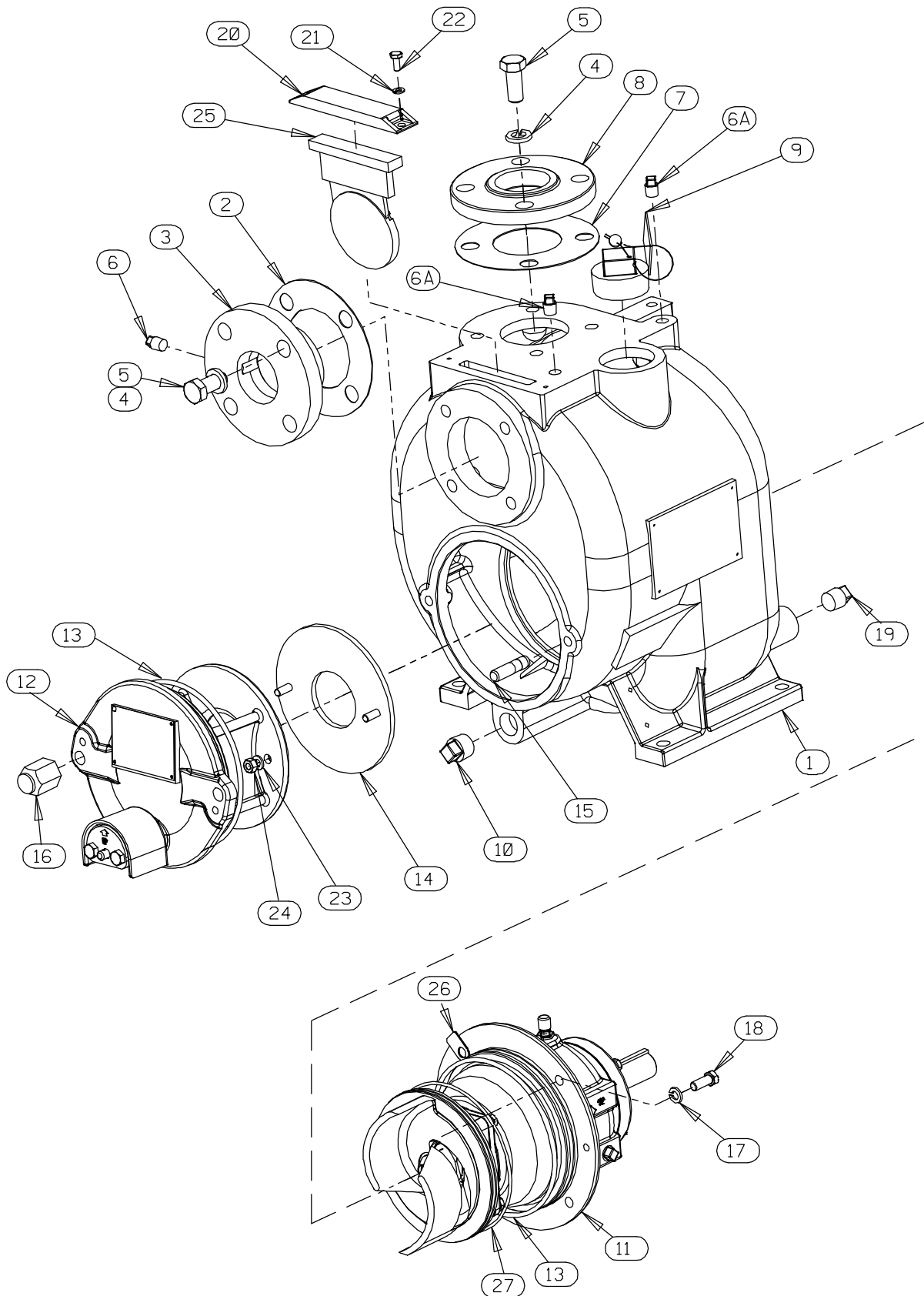

Figure 1. Pump Model T2A61-B, Including /F, /FM

**PARTS LIST**  
**Pump Model T2A61-B, Including /F, /FM**  
 (From S/N 1250109 Up)

If your pump serial number is followed by an "N", your pump is **NOT** a standard production model. Contact the Gorman-Rupp Company to verify part numbers.

ITEM NO.	PART NAME	PART NUMBER	QTY	ITEM NO.	PART NAME	PART NUMBER	QTY
1	PUMP CASING	SEE NOTE BELOW	1	22	HEX HEAD CAP SCREW	B0402-1/2 15991	2
2	SUCTION FLG GSKT	38683-273 19370	1	23	LOCK WASHER	J05 15991	2
3	SUCTION FLANGE	38641-039 10000	1	24	HEX NUT	D05 15991	2
4	LOCK WASHER	J10 15991	8	25 *	FLAP VALVE	46411-132 24010	1
5	HEX HEAD CAP SCREW	B1006 15991	8	26	ROT ASSY ADJ SHIM SET	48261-058	4
6	PIPE PLUG	P04 15079	1	27 *	O-RING	25152-259	1
6A	PIPE PLUG	P04 15079	2	NOT SHOWN:			
7 *	FLANGE GASKET	25113-031	1		DISCHARGE STICKER	6588BJ	1
8	COMPANION FLANGE	1688A 10010	1		PRIMING STICKER	6588AH	1
9	FILL PLUG ASSY	48271-068	1		SUCTION STICKER	6588AG	1
10	CASING DRAIN PLUG	P12 15079	1		WARNING DECAL	2613FE	1
11	REPAIR ROTATING ASSY	44163-339	1		ROTATION DECAL	2613M	1
12	BACK COVER PLATE ASSY	42111-813	1		NAME PLATE	38818-040 13990	1
	-WARNING PLATE	2613EV 13990	1		DRIVE SCREW	BM#04-03 17000	4
	-DRIVE SCREW	BM#04-03 17000	4		LUBE DECAL	11421	1
	-WARNING DECAL	38816-302	1		G-R DECAL	GR-03	1
	-PRESS RELIEF VALVE	46431-803	1	OPTIONAL:			
13 *	O-RING	25152-363	2		/F FLANGES		
14 *	WEAR PLATE ASSY	46451-370 17090	1		-SUCTION FLANGE	38642-009 10000	1
15	STUD	C0808 15991	2		-DISCHARGE FLANGE	38642-008 10000	1
16	BACK COVER NUT	31871-075 15000	2		/FM METRIC FLANGES		
17	LOCK WASHER	J06 15991	4		-SUCTION FLANGE	38642-006 10000	1
18	HEX HEAD CAP SCREW	B0604 15991	4		-DISCHARGE FLANGE	38642-007 10000	1
19	PIPE PLUG	P08 15079	2		/WW SUCTION FLANGE	38642-009 10000	1
20	FLAP VALVE COVER	38346-617 17070	1				
21	LOCK WASHER	J04 15991	2				

\* INDICATES PARTS RECOMMENDED FOR STOCK

INCLUDED WITH REPAIR	46472-719	1
PUMP CASING ASSY		

ILLUSTRATION

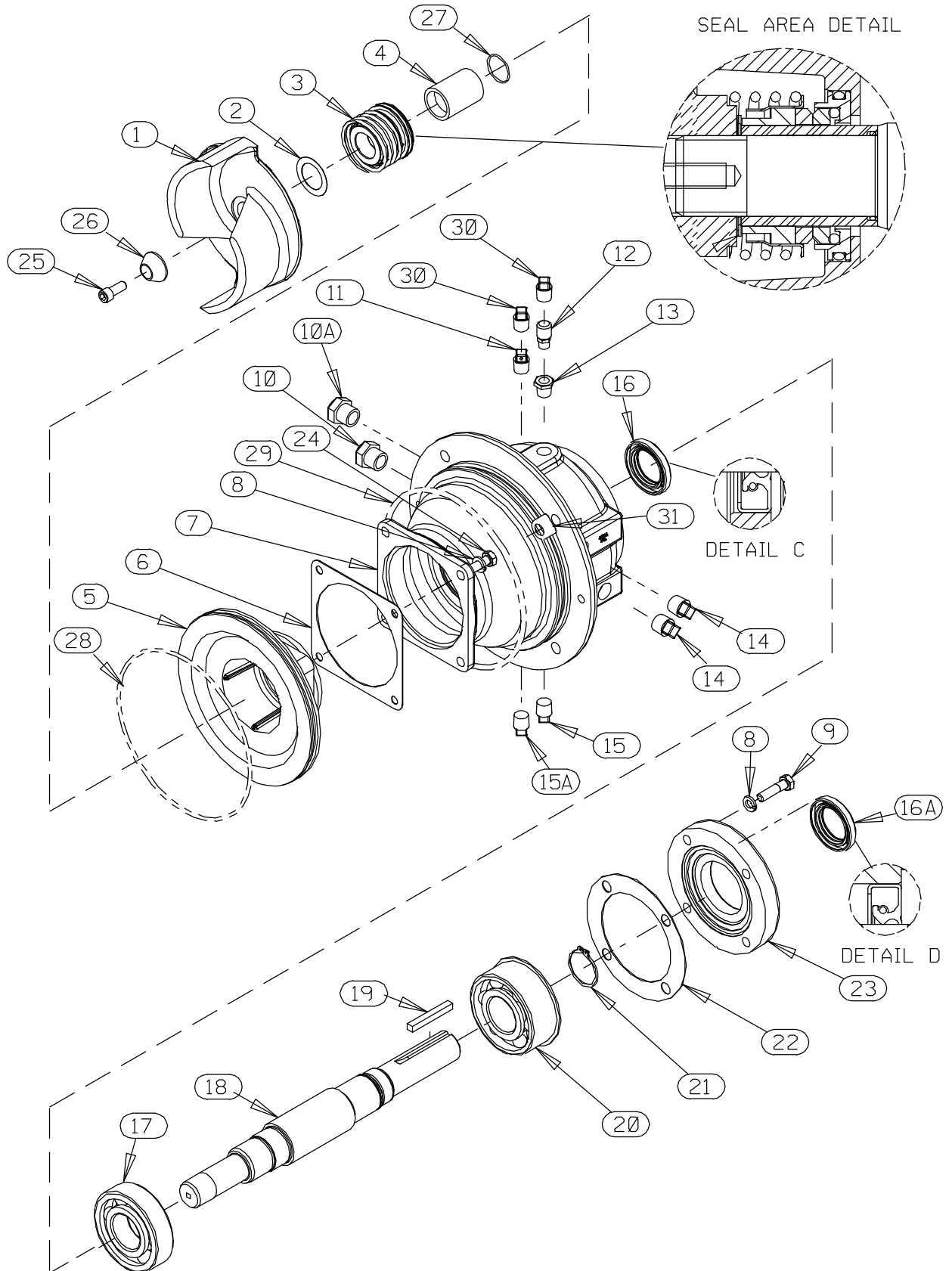

Figure 2. Repair Rotating Assembly

## PARTS LIST

### Repair Rotating Assembly

ITEM NO.	PART NAME	PART NUMBER	QTY	ITEM NO.	PART NAME	PART NUMBER	QTY
1 *	IMPELLER	38615-093 17070	1	17 *	BALL BEARING	23276-008	1
2	IMP ADJ SHIM SET	2X 17090	1	18	IMPELLER SHAFT	38514-565 1706H	1
3 *	MECH SEAL ASSY	46512-159	1	19 *	KEY	N0408 15990	1
☞ 4 *	SHAFT SLEEVE	31441-037 17070	1	20 *	BALL BEARING	23422-408	1
5	SEAL PLATE	38272-119 17070	1	21	RETAINING RING	S248	1
6 *	GASKET	38687-556 20000	1	22 **	BRG CAP GASKET	38683-268 18000	1
7	BRG HOUSING	38251-208 10000	1	23	BEARING CAP	38322-221 10000	1
8	LOCK WASHER	J05 15991	8	24	HEX HD CAP SCREW	B0503-1/2 15991	4
9	HEX HD CAP SCREW	B0505 15991	4	25	SOC HD CAP SCREW	DM0503 17040	1
10	BRG CVTY SIGHT GAUGE	26714-011	1	26	IMPELLER WASHER	31167-025 17070	1
10A	SEAL CVTY SIGHT GAUGE	26714-011	1	27 *	SHAFT SLEEVE O-RING	25154-020	1
11	VENTED PIPE PLUG	4823 15079	1	28 *	SEAL PLATE O-RING	25152-259	1
12	AIR VENT	S1530	1	29 *	BRG HOUSING O-RING	25152-363	1
13	PIPE BUSHING	AP0402 15079	1	30	SHIPPING PLUG	11495 15079	2
14	PIPE PLUG	P06 15079	2	31	ROT ASSY ADJ SHIM SET	48261-058	4
15	BRG CVTY DRAIN PLUG	P04 15079	1	NOT SHOWN:			
15A	SEAL CVTY DRAIN PLUG	P04 15079	1		ROTATION DECAL	2613M	1
16 *	OIL SEAL	25258-344	1		INSTRUCTION TAG	6588U	1
16A *	OIL SEAL	25258-344	1				

\* INDICATES PARTS RECOMMENDED FOR STOCK

\*\* FOR PUMPS WITH SERIAL NUMBERS **BELOW** 1244270, ORDER 38683-274/18000 BEARING CAP GASKET.  
IF **BOTH** BEARING CAP AND GASKET MUST BE REPLACED, ORDER PARTS LISTED ABOVE.

☞ IF YOUR PUMP WAS NOT EQUIPPED FROM THE FACTORY WITH A SHAFT SLEEVE O-RING, ORDER AN O-RING (ITEM 27) WHEN REPLACING THE SHAFT SLEEVE.