

ILLUSTRATION

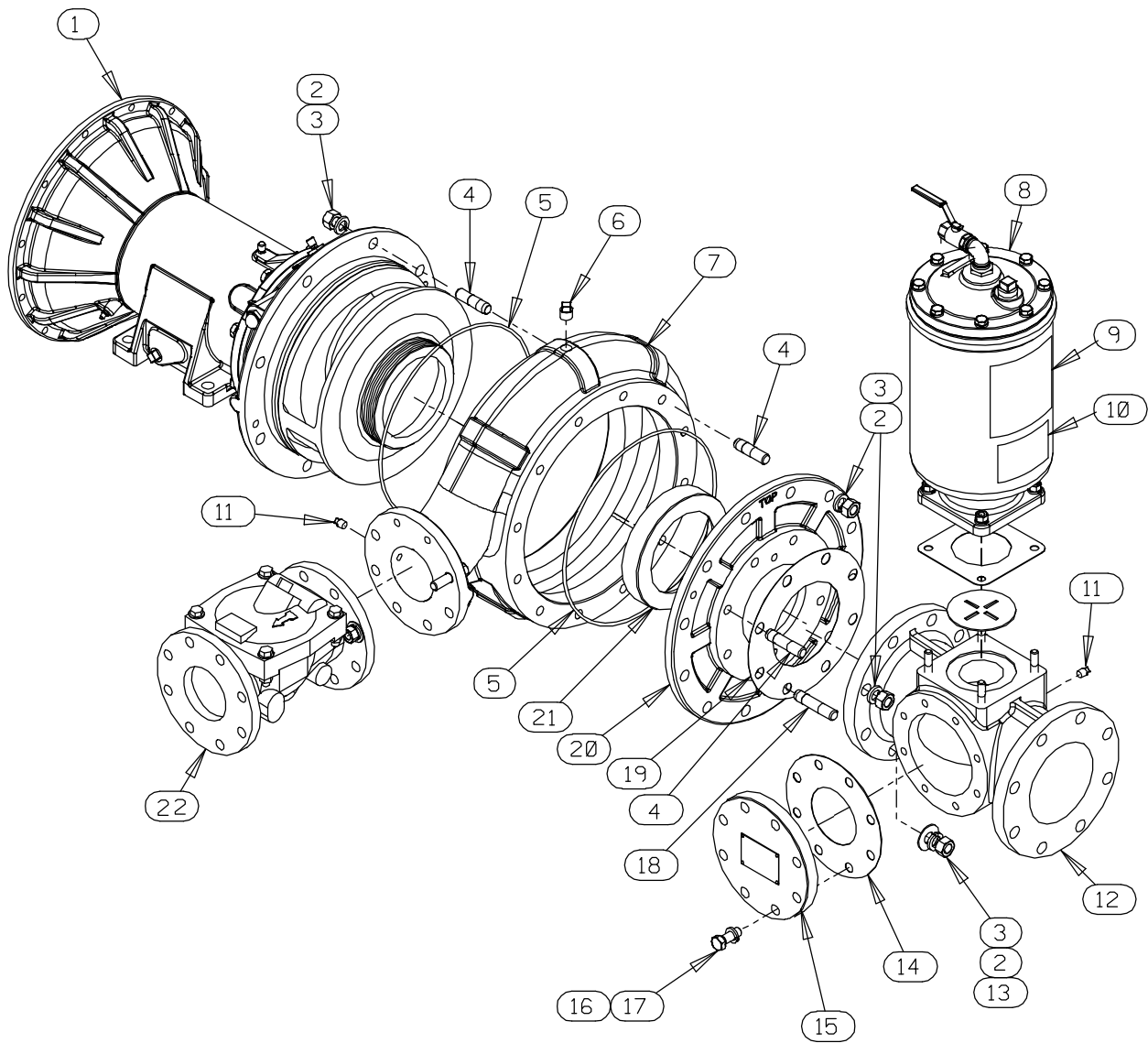

Figure 4. Pump End Assembly

Pump End Assembly

PARTS LIST

| ITEM NO. | PART NAME | PART NUMBER | QTY |
|------------|------------------------------------|-----------------|-----|
| 1 | REPAIR ROTATING ASSEMBLY | 44163-690 | 1 |
| 2 | LOCK WASHER | J12 17090 | 28 |
| 3 | HEX NUT | D12 17090 | 28 |
| ☞ 4 | STUD | C1211 1706G | 26 |
| 5 | * O-RING | 25154-383 | 2 |
| ☞ 6 | PIPE PLUG | P08 17090 | 3 |
| ☞ 7 | PUMP CASING | SEE NOTE BELOW | 1 |
| 8 | PRIMING HOPPER KIT | 48275-008 | 1 |
| 9 | G-R DECAL | GR-06 | 1 |
| 10 | PRIME AIRE PLUS DECAL | 38812-099 | 1 |
| 11 | PIPE PLUG | P04 17090 | 2 |
| 12 | 6" SUCTION SPOOL | 38644-814 17180 | 1 |
| 13 | FLAT WASHER | KB12 17090 | 2 |
| 14 | * GASKET | 1676G 19410 | 1 |
| 15 | 4" BLIND FLANGE ASSEMBLY | 42111-434 | 1 |
| 16 | LOCK WASHER | J10 17090 | 8 |
| 17 | HEX HEAD CAP SCREW | B1007 17090 | 8 |
| 18 | STUD | C1213 1706G | 2 |
| 19 | GASKET | 1679G 19410 | 1 |
| 20 | SUCTION HEAD | 38246-627 17180 | 1 |
| 21 | * WEAR RING | 38691-374 1718H | 1 |
| 22 | CHECK VALVE KIT | 48274-022 | 1 |
| | * -FLANGE GASKET | 1676G 19040 | 1 |
| | -CHECK VALVE | 26642-301 | 1 |
| | * -FLAPPER | 26688-019 | 1 |
| | * -COVER GASKET | 26688-006 | 1 |
| NOT SHOWN: | | | |
| | DRIVE ASSEMBLY | 44162-162 | 1 |
| | DISCHARGE STICKER | 6588BJ | 1 |
| | SUCTION STICKER | 6588AG | 1 |
| | WARNING DECAL | 2613FE | 1 |
| | INSTRUCTION TAG | 38817-104 | 1 |
| | NAMEPLATE BLANK | 38819-002 13000 | 1 |
| | DRIVE SCREW | BM#04-03 17000 | 4 |
| ☞ | INCLUDED W/REPAIR PUMP CASING ASSY | 46474-913 | 1 |

* INDICATES PARTS RECOMMENDED FOR STOCK

ILLUSTRATION

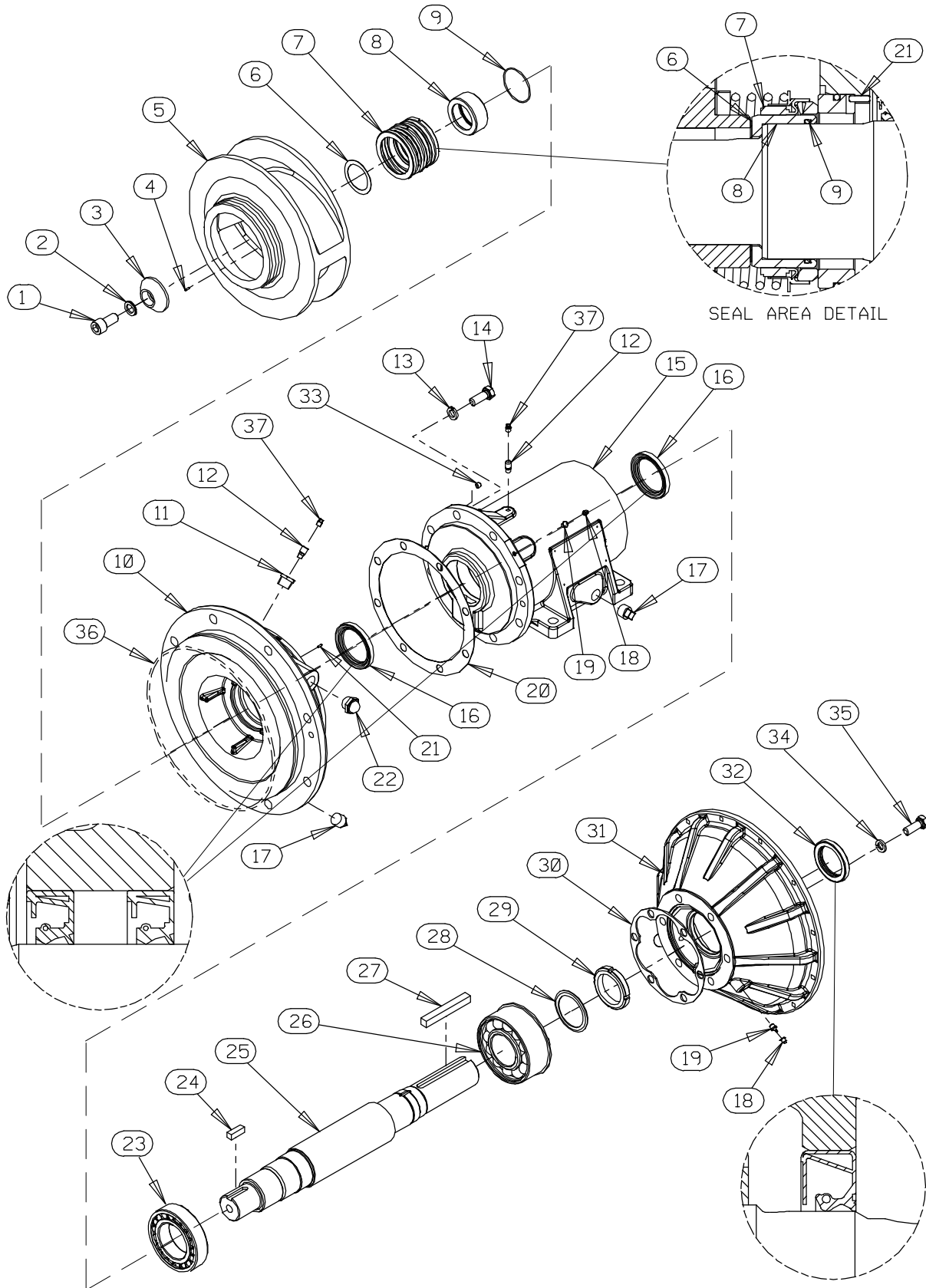

Figure 5. Repair Rotating Assembly

PARTS LIST
Repair Rotating Assembly

| ITEM NO. | PART NAME | PART NUMBER | QTY |
|-------------|-----------------------|-----------------|-----|
| 1 | SOCKET HEAD CAP SCREW | 21472-501 | 1 |
| 2 | WASHER NORD-LOCK 3/4" | 21177-254 | 1 |
| 3 | IMPELLER WASHER | 31167-042 17090 | 1 |
| 4 | ROLL PIN | 21154-801 | 1 |
| 5 | IMPELLER | 38621-733 1718H | 1 |
| 6 | * SHIM SET | 48261-033 | 1 |
| 7 | * 3.25" MECH SEAL | 25285-822 | 1 |
| 8 | * SHAFT SLEEVE | 31163-022 1706H | 1 |
| 9 | * O-RING | 25154-150 | 1 |
| 10 | SEAL PLATE | 38272-533 1718H | 1 |
| 11 | REDUCER PIPE BUSHING | AP1202 15079 | 1 |
| 12 | AIR VENT | S1530 | 2 |
| 13 | LOCK WASHER | J10 17090 | 8 |
| 14 | HEX HEAD CAP SCREW | B1007 17090 | 8 |
| 15 | PEDESTAL | 38257-212 10000 | 1 |
| 16 | * LIP SEAL | 25227-856 | 2 |
| 17 | PIPE PLUG | P12 15079 | 3 |
| 18 | CAP PLUG | 25141-151 | 4 |
| 19 | LUBE FITTING | S186 | 4 |
| 20 | * GASKET | 38683-665 19370 | 1 |
| 21 | ROLL PIN | S2197 | 1 |
| 22 | SIGHT GAUGE | S1471 | 2 |
| 23 | * ROLLER BEARING | 23535-001 | 1 |
| 24 | * IMPELLER KEY | N0806 17040 | 1 |
| 25 | IMPELLER SHAFT | 38512-545 1706X | 1 |
| 26 | * BEARING | 23422-417 | 1 |
| 27 | * SHAFT KEY | N1020 15990 | 1 |
| 28 | LOCKING TAB COLLAR | 23962-515 | 1 |
| 29 | BEARING LOCKNUT | 23962-015 | 1 |
| 30 | * BEARING CAP GASKET | 38683-664 19060 | 1 |
| 31 | DRIVE FLANGE - SAE 3 | 38545-030 10000 | 1 |
| 32 | * OIL SEAL | 25258-845 | 1 |
| 33 | SOCKET HEAD PIPE PLUG | PC02 15079 | 2 |
| 34 | LOCK WASHER | J10 15991 | 6 |
| 35 | HEX HEAD CAP SCREW | B1007 15991 | 6 |
| 36 | * O-RING | 25154-383 | 1 |
| 37 | SHIPPING PLUG | 11495C 15079 | 2 |
| NOT SHOWN: | | | |
| | INSTRUCTION TAG | 6588U | 1 |
| | LUBRICATION DECAL | 38817-103 | 1 |

* INDICATES PARTS RECOMMENDED FOR STOCK

ILLUSTRATION

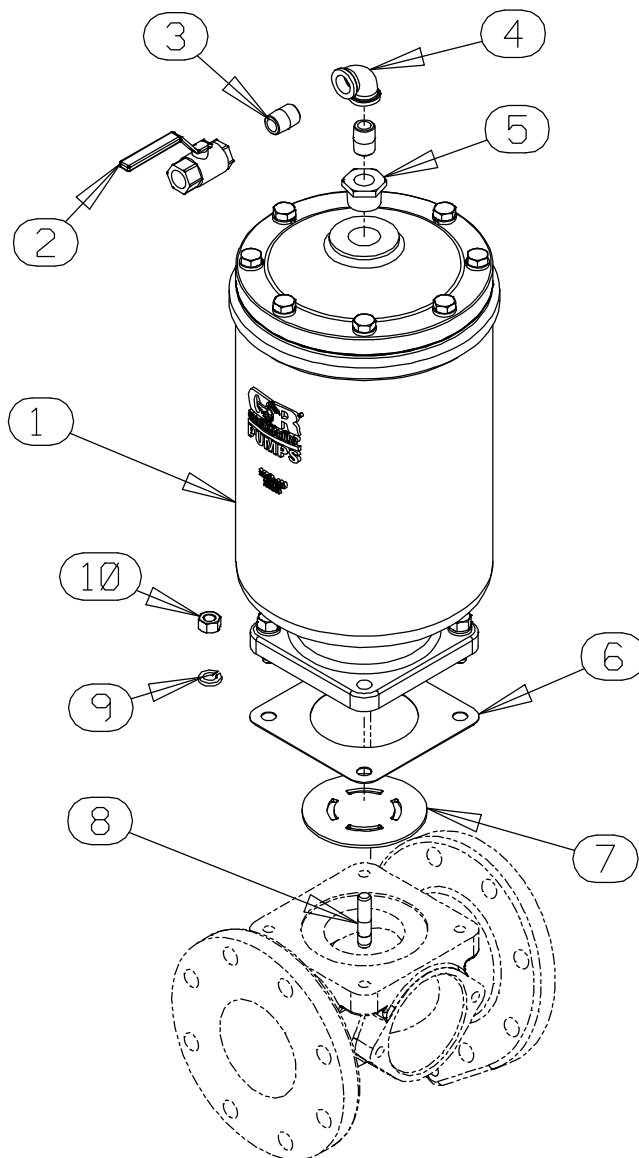

Figure 6. Priming Chamber Kit
PARTS LIST

| ITEM NO. | PART NAME | PART NUMBER | QTY |
|----------|-------------------------|-----------------|-----|
| 1 | PRIMING HOPPER ASSEMBLY | 46112-711 | 1 |
| 2 | BALL VALVE | 26631-114 | 1 |
| 3 | CLOSE PIPE NIPPLE | T08 17040 | 2 |
| 4 | PIPE ELBOW | R08 17040 | 1 |
| 5 | REDUCER PIPE BUSHING | AP1608 17040 | 1 |
| 6 | * GASKET | 38687-053 19410 | 1 |
| 7 | BAFFLE | 31113-011 17040 | 1 |
| 8 | STUD | C0809 1706G | 4 |
| 9 | LOCK WASHER | J08 17090 | 4 |
| 10 | HEX NUT | D08 17040 | 4 |

* INDICATES PARTS RECOMMENDED FOR STOCK

ILLUSTRATION

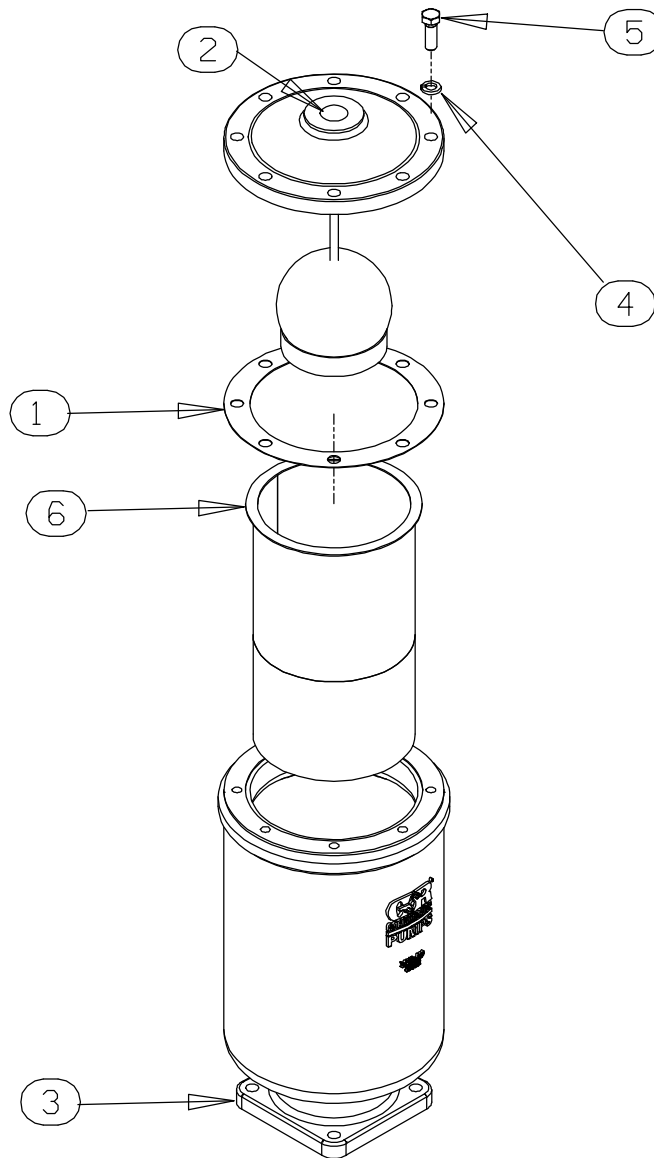

Figure 7. Priming Chamber Assembly
PARTS LIST

| ITEM NO. | PART NAME | PART NUMBER | QTY |
|----------|------------------------|-----------------|-----|
| 1 | * PRIMING VALVE GASKET | 38683-657 19410 | 1 |
| 2 | PRIMING VALVE | 26664-008 | 1 |
| | -ORIFICE BUTTON | 26688-021 | 1 |
| 3 | PRIMING CHAMBER | 38343-020 17040 | 1 |
| 4 | LOCK WASHER | J08 17090 | 8 |
| 5 | HEX HEAD CAP SCREW | B0806 17090 | 8 |
| 6 | STRAINER ASSEMBLY | 46641-024 17040 | 1 |

* INDICATES PARTS RECOMMENDED FOR STOCK

ILLUSTRATION

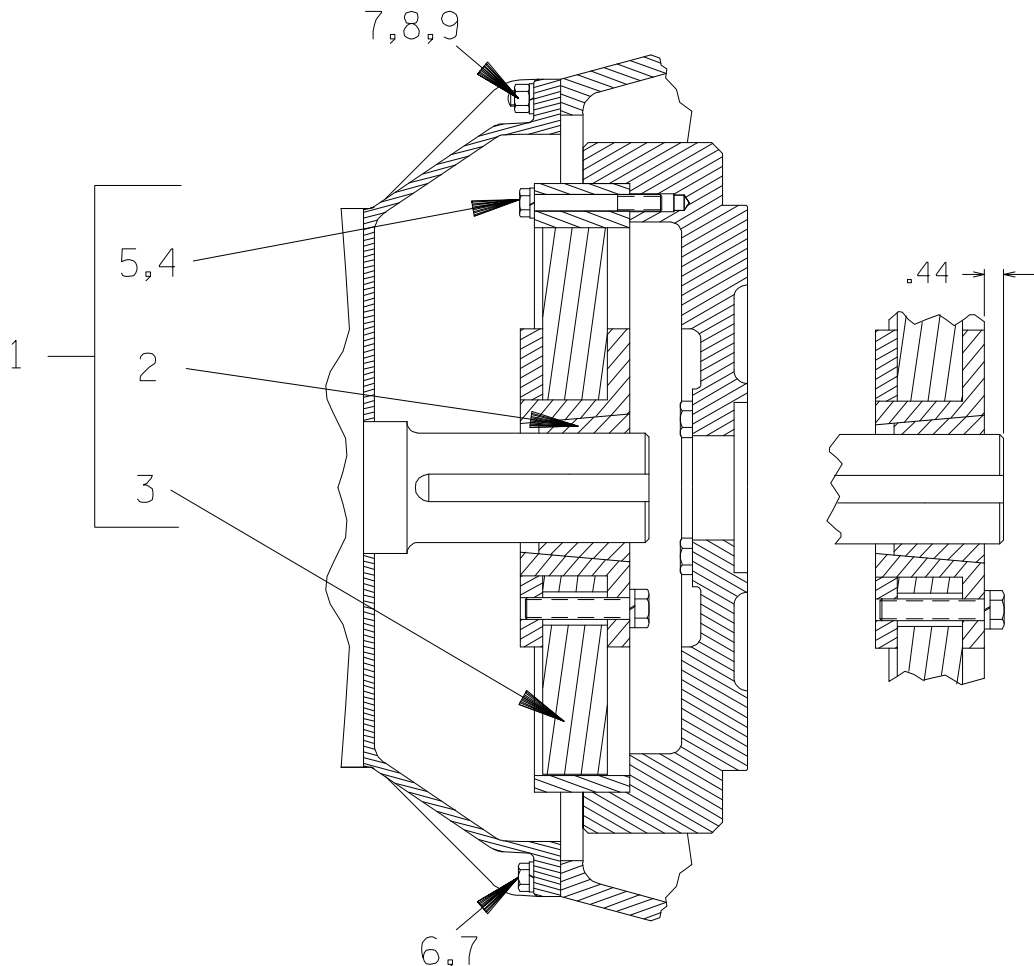











Figure 8. Drive Assembly

PARTS LIST

| ITEM NO. | PART NAME | PART NUMBER | QTY |
|---|--------------------|-------------|-----|
| 1 | COUPLING KIT | 48112-006 | 1 |
| 2 | -BUSHING | 24131-492 | 1 |
| 3 | -COUPLING ASSEMBLY | 24391-106 | 1 |
| 4 | LOCKWASHER | 21171-536 | 8 |
|  5 | HEX HEAD CAPSCREW | B0612 15991 | 8 |
|  5 | HEX HEAD CAPSCREW | 22645-174 | 8 |
|  6 | HEX HEAD CAPSCREW | B0606 15991 | 10 |
|  6 | HEX HEAD CAPSCREW | 22645-166 | 12 |
|  7 | LOCKWASHER | J06 15991 | 12 |
|  7 | LOCKWASHER | 21171-511 | 12 |
|  8 | STUD | C0606 15991 | 2 |
|  8 | STUD | 26821-879 | 2 |
|  9 | HEX NUT | D06 15991 | 2 |
|  9 | HEX NUT | 26821-932 | 2 |

 USE FOR SAE APPLICATIONS

 USE FOR METRIC APPLICATIONS