

ILLUSTRATION

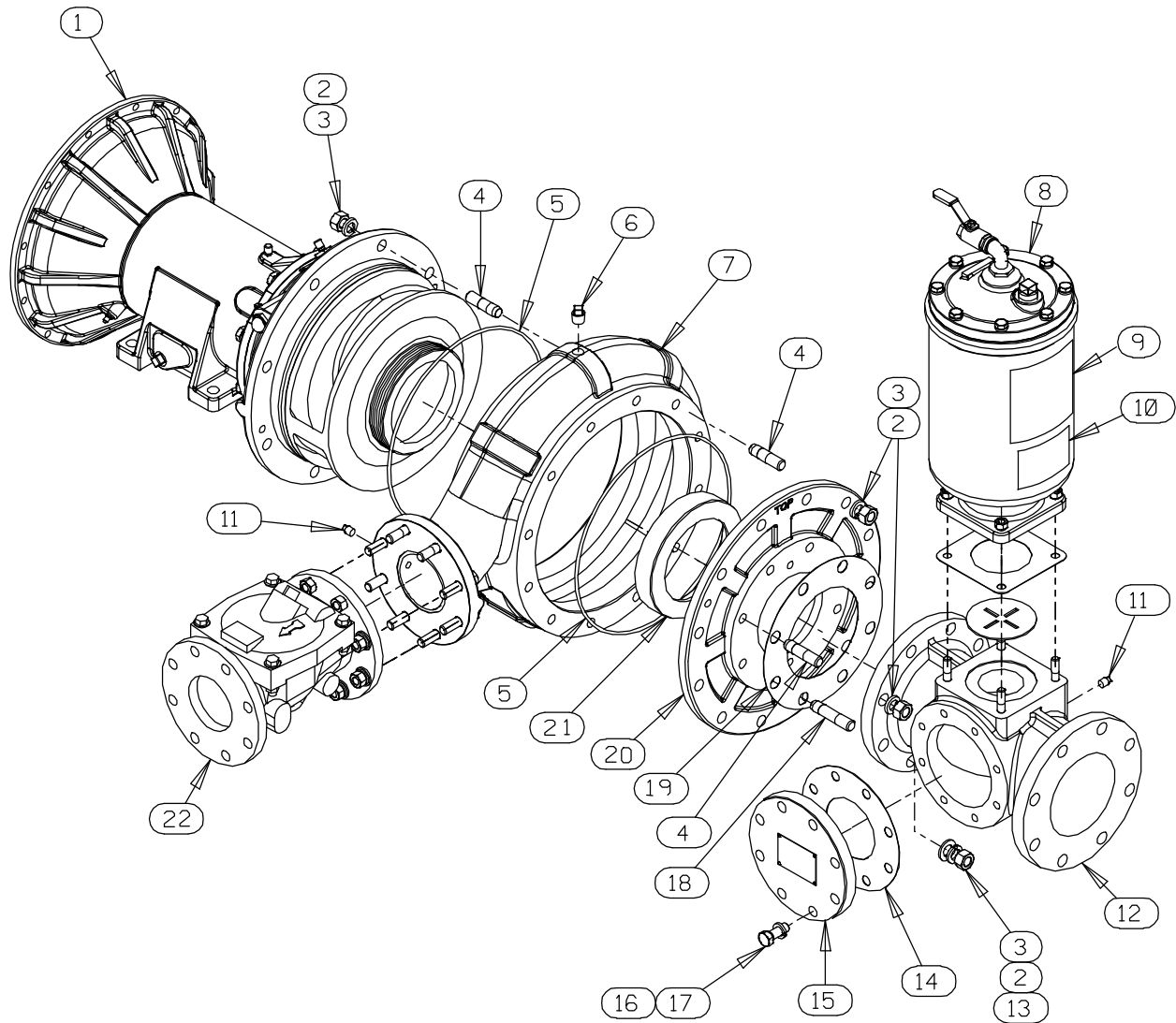

Figure 4. Pump End Assembly

## Pump End Assembly

## PARTS LIST

ITEM NO.	PART NAME	PART NUMBER	QTY
1	REPAIR ROTATING ASSEMBLY	44163-680	1
2	LOCK WASHER	J12 15991	28
3	HEX NUT	D12 15991	28
☞ 4	STUD	C1211 15991	26
5	* O-RING	25152-383	2
☞ 6	PIPE PLUG	P08 15079	3
☞ 7	PUMP CASING	38218-304 11010	1
8	PRIMING CHAMBER KIT	48275-005	1
9	G-R DECAL	GR-06	1
10	PRIME AIRE PLUS DECAL	38812-099	1
11	PIPE PLUG	P04 15079	2
12	6" SUCTION SPOOL	38644-814 10000	1
13	WASHER SAE 3/4	21161-446	2
14	* GASKET	25113-034	1
15	4" BLIND FLANGE ASSEMBLY	42111-358	1
16	LOCK WASHER	J10 15991	8
17	HEX HEAD CAP SCREW	B1007 15991	8
18	STUD	C1213 15991	2
19	* GASKET	25113-036	1
20	SUCTION HEAD	38246-627 10000	1
21	* WEAR RING	38691-374 11010	1
22	CHECK VALVE KIT 4"	48274-025	1
	-FLANGE GASKET	25113-034	1
	-CHECK VAVLE	26642-124	1
	* -FLAPPER	26688-005	1
	* -COVER O-RING	25152-366	1
NOT SHOWN:			
	DRIVE ASSEMBLY	44162-162	1
	DISCHARGE STICKER	6588BJ	1
	SUCTION STICKER	6588AG	1
	WARNING DECAL	2613FE	1
	INSTRUCTION TAG	38817-104	1
	NAMEPLATE BLANK	38819-002 13000	1
	DRIVE SCREW	BM#04-03 17000	4
☞	INCLUDED W/REPAIR PUMP CASING ASSY	46474-364	1

\* INDICATES PARTS RECOMMENDED FOR STOCK

ILLUSTRATION

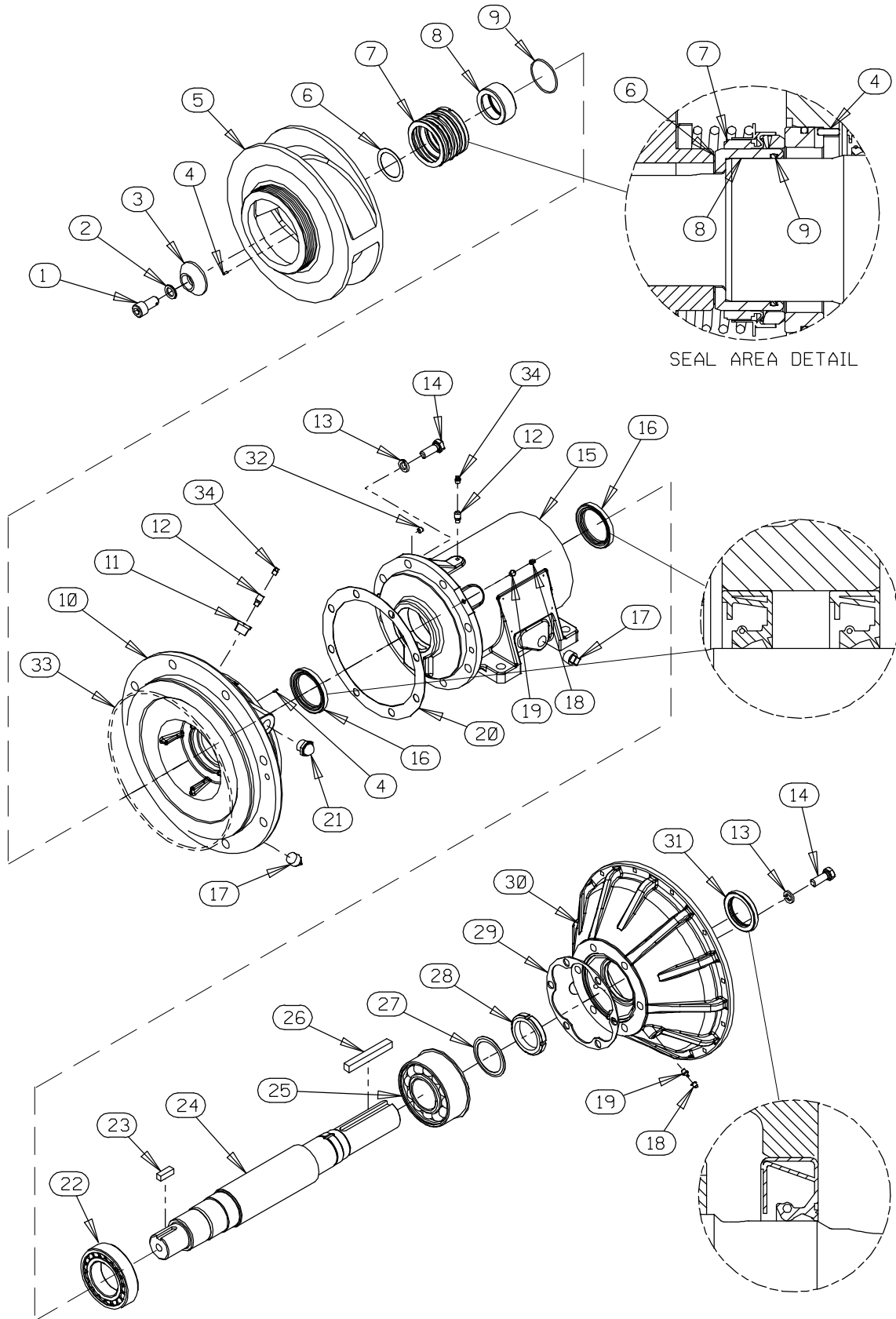

Figure 5. Repair Rotating Assembly

**PARTS LIST**  
**Repair Rotating Assembly**

ITEM NO.	PART NAME	PART NUMBER	QTY
1	SOCKET HEAD CAP SCREW	DM1206 15991	1
2	WASHER NORD-LOCK 3/4"	21177-224	1
3	IMPELLER WASHER	31167-042 17000	1
4	ROLL PIN	S2197	2
5	IMPELLER	38621-733 11010	1
6	* SHIM SET	48261-033	1
7	* 3.25" MECH SEAL	25285-822	1
8	* SHAFT SLEEVE	31163-022 17000	1
9	* O-RING	25152-150	1
10	SEAL PLATE	38272-533 10000	1
11	REDUCER PIPE BUSHING	AP1202 15079	1
12	AIR VENT	S1530	2
13	LOCK WASHER	J10 15991	14
14	HEX HEAD CAP SCREW	B1007 15991	14
15	PEDESTAL	38257-212 10000	1
16	* LIP SEAL	25227-856	2
17	PIPE PLUG	P12 15079	3
18	CAP PLUG	25141-151	4
19	LUBE FITTING	S186	4
20	* GASKET	38683-665 19370	1
21	SIGHT GAUGE	S1471	2
22	* ROLLER BEARING	23535-001	1
23	* IMPELLER KEY	N0806 15990	1
24	IMPELLER SHAFT	38512-545 1600X	1
25	* BEARING	23422-417	1
26	* SHAFT KEY	N1020 15990	1
27	LOCKING TAB COLLAR	23962-515	1
28	BEARING LOCKNUT	23962-015	1
29	* BEARING CAP GASKET	38683-664 19060	1
30	DRIVE FLANGE - SAE 3	38545-030 10000	1
31	* OIL SEAL	25258-845	1
32	SOCKET HEAD PIPE PLUG	PC02 15079	2
33	* O-RING	25152-383	1
34	SHIPPING PLUG	11495C 15079	2
NOT SHOWN:			
	INSTRUCTION TAG	6588U	1
	LUBRICATION DECAL	38817-103	1

\* INDICATES PARTS RECOMMENDED FOR STOCK

ILLUSTRATION

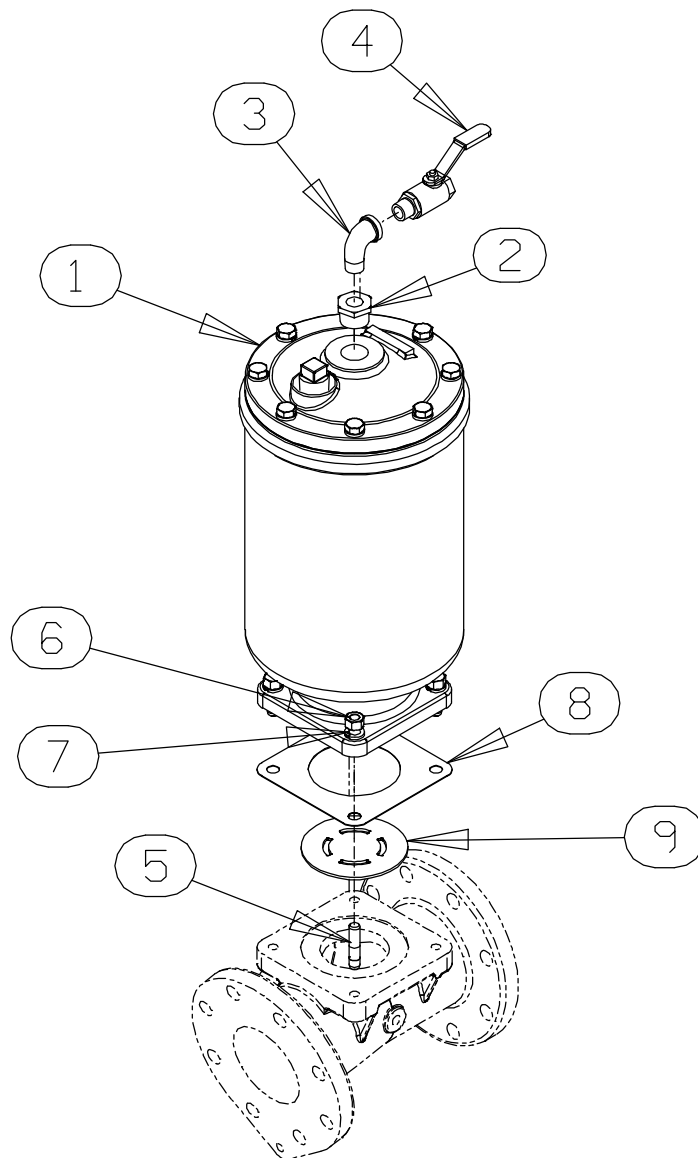

Figure 6. Priming Chamber Kit

PARTS LIST

ITEM NO.	PART NAME	PART NUMBER	QTY
1	PRIMING CHAMBER ASSY	46112-709	1
2	PIPE BUSHING	AP1608 15070	1
3	STREET ELBOW	RS08 11999	1
4	BALL VALVE	26631-052	1
5	STUD	C0809 15991	4
6	HEX NUT	D08 15991	4
7	LOCK WASHER	J08 15991	4
8	* GASKET	38687-053 19060	1
9	BAFFLE	31113-011 17000	1

\* INDICATES PARTS RECOMMENDED FOR STOCK

ILLUSTRATION

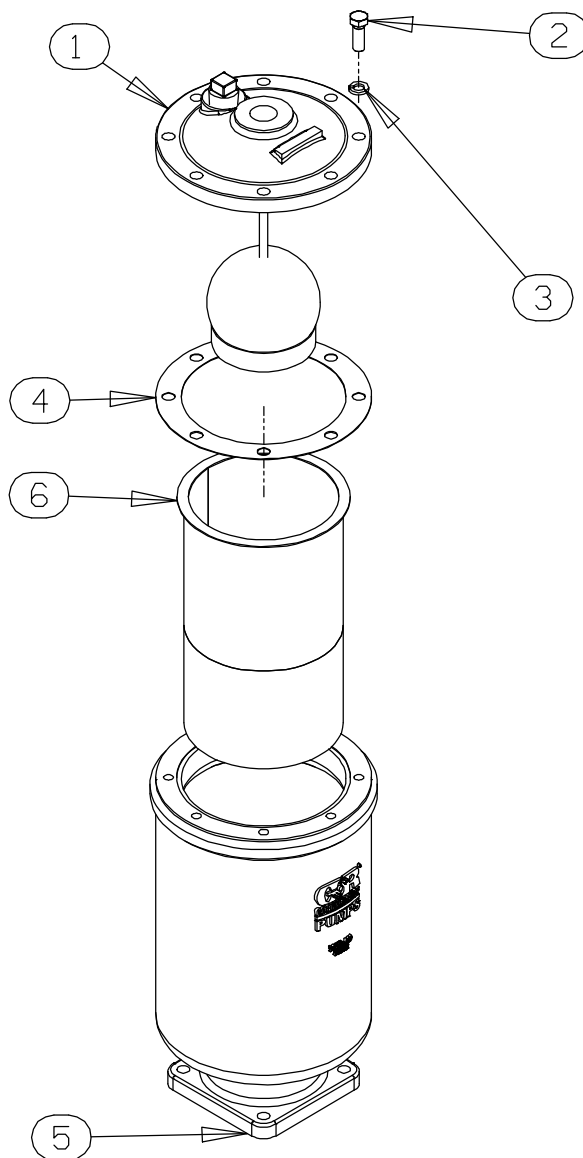

Figure 7. Priming Chamber Assembly

PARTS LIST

ITEM NO.	PART NAME	PART NUMBER	QTY
1	PRIMING VALVE	26664-007	1
	-ORIFICE BUTTON	26688-021	1
2	HEX HD CAPSCREW	B0806 15991	8
3	LOCKWASHER	J08 15991	8
4	PRIMING VALVE GASKET	38683-657 19060	1
5	PRIMING CHAMBER	38343-020 10000	1
6	STRAINER ASSY	46641-222 17000	1

\* INDICATES PARTS RECOMMENDED FOR STOCK

ILLUSTRATION

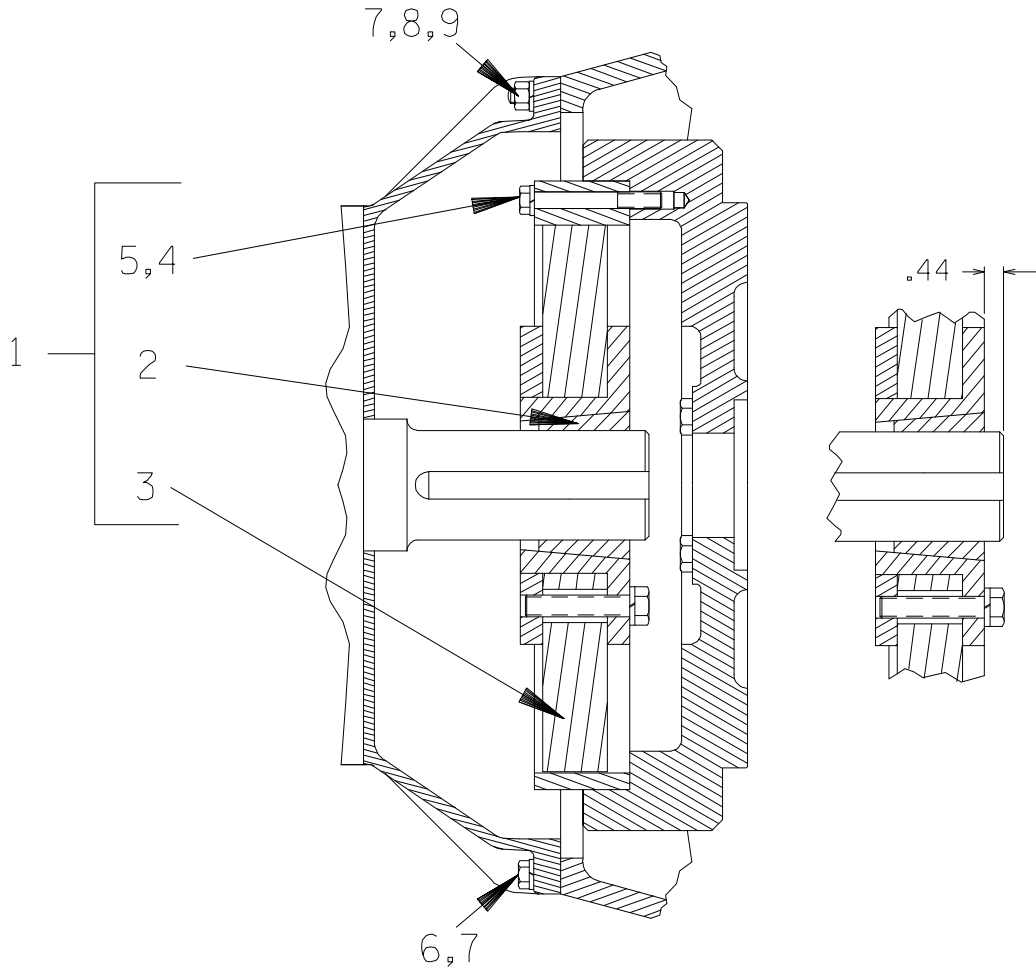













Figure 8. Drive Assembly

PARTS LIST

ITEM NO.	PART NAME	PART NUMBER	QTY
1	COUPLING KIT	48112-006	1
2	-BUSHING	24131-492	1
3	-COUPLING ASSEMBLY	24391-106	1
4	LOCKWASHER	21171-536	8
5	 SOCKET HEAD CAPSCREW	B0612 15991	8
5	 SOCKET HEAD CAPSCREW	22645-174	8
6	 HEX HEAD CAPSCREW	B0606 15991	10
6	 HEX HEAD CAPSCREW	22645-166	12
7	 LOCKWASHER	J06 15991	12
7	 LOCKWASHER	21171-511	12
8	 STUD	C0606 15991	2
8	 STUD	26821-879	2
9	 HEX NUT	D06 15991	2
9	 HEX NUT	26821-932	2
	 USE FOR SAE APPLICATIONS		
	 USE FOR METRIC APPLICATIONS		