

ILLUSTRATION

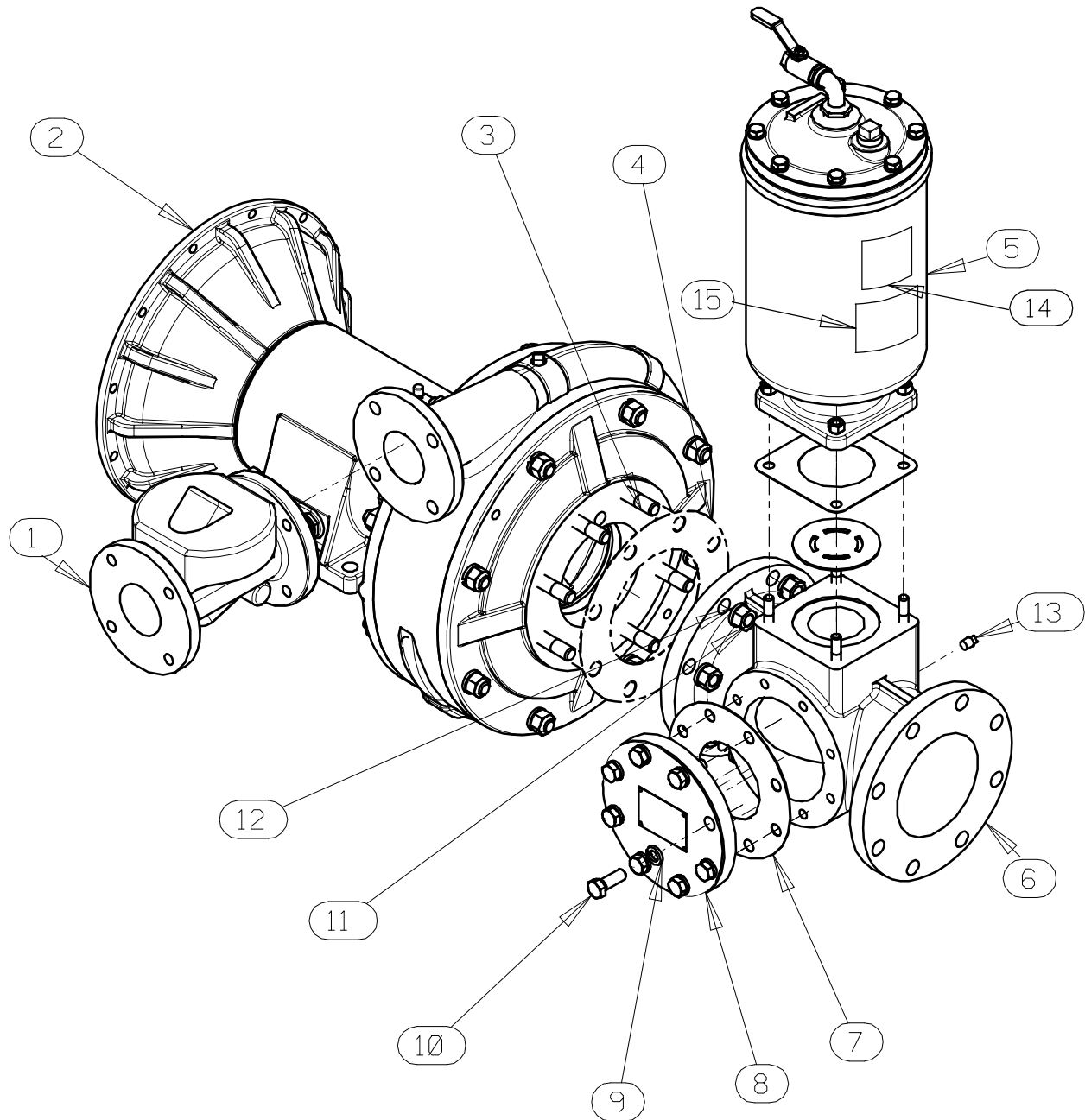

Figure 4. 46133-444 Pump End Assembly

## 46133-444 Pump End Assembly

## PARTS LIST

ITEM NO.	PART NAME	PART NUMBER	MAT'L CODE	QTY
1	CHECK VALVE KIT	48274-002	----	1
	-CHECK VALVE	26642-123	----	1
	*   -COVER GASKET	26688-012	----	1
	*   -FLAPPER	26688-011	----	1
	*   -FLANGE GASKET	25113-033	----	1
2	63P60-(SAE 3/11.5) PUMP END	46133-443	----	1
3	STUD	C1213	15991	8
4	* GASKET	25113-036	----	1
5	PRIMING CHAMBER KIT	48275-005	----	1
6	6" SUCTION SPOOL	38644-814	10000	1
7	* GASKET	25113-034	----	1
8	4" BLIND FLANGE ASSEMBLY	42111-358	----	1
9	LOCK WASHER	J10	15991	8
10	HEX HEAD CAP SCREW	B1007	15991	8
11	HEX NUT	D12	15991	8
12	LOCK WASHER	J12	15991	8
13	PIPE PLUG	P04	15079	1
14	G-R DECAL	GR06	----	1
15	PRIME AIRE PLUS DECAL	38812-099	----	1
NOT SHOWN:				
	SUCTION STICKER	6588AG	----	1
	DISCHARGE STICKER	6588BJ	----	1
	WARNING DECAL	2613FE	----	1
	G-R DECAL	GR-06	----	1
	LUBRICATION DECAL	11421A	----	1
	OIL LEVEL DECAL	38816-123	----	1
	PRIME AIRE PLUS DECAL	38812-099	----	1
	6" STRAINER	46641-005	24150	1
	DRIVE ASSEMBLY	44162-167	----	1
	INSTRUCTION TAG	38817-085	----	1
	NAME PLATE	38818-156	13000	1
	DRIVE SCREW	BM#04-03	17000	4

\* INDICATES PARTS RECOMMENDED FOR STOCK

ILLUSTRATION

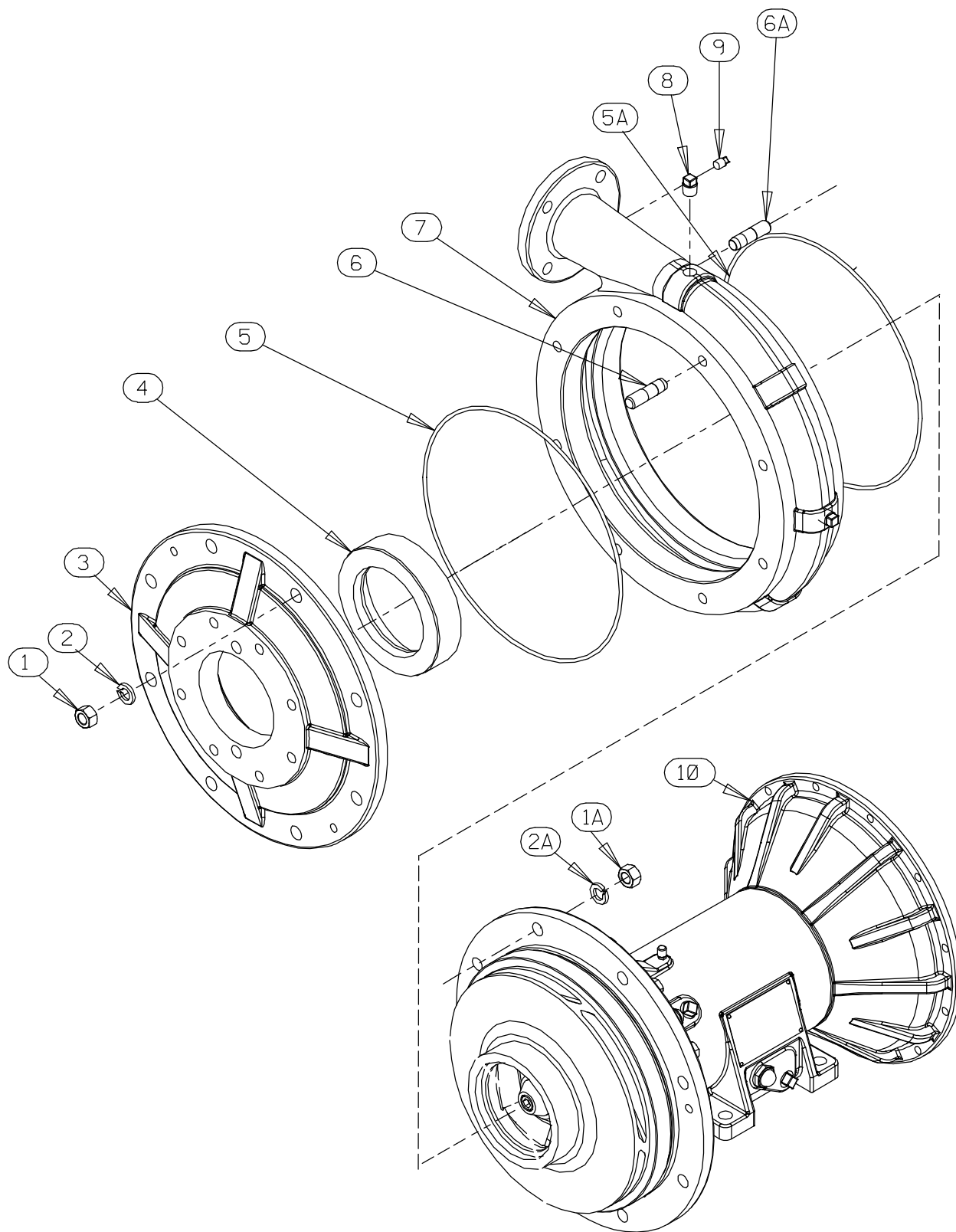

Figure 5. 46133-443 Pump End Assembly

**PARTS LIST**  
**46133-443 Pump End Assembly**

ITEM NO.	PART NAME	PART NUMBER	MAT'L CODE	QTY
1	HEX NUT	D12	15991	8
1A	HEX NUT	D12	15991	8
2	LOCK WASHER	J12	15991	8
2A	LOCK WASHER	J12	15991	8
3	SUCTION HEAD	38246-615	11010	1
4	* WEAR RING	38691-369	11010	1
5	* SUCTION HEAD O-RING	25152-384	---	1
5A	* PUMP CASING O-RING	25152-384	---	1
6	☞ STUD	C1211	15991	8
6A	☞ STUD	C1211	15991	8
7	☞ PUMP CASING	SEE NOTE BELOW		1
8	☞ PIPE PLUG	P08	15079	3
9	☞ PIPE PLUG	P04	15079	1
10	REPAIR ROTATING ASSY	44163-522	---	1
☞	INCLUDED W/REPAIR PUMP CASING ASSY	46474-907	---	1

\* INDICATES PARTS RECOMMENDED FOR STOCK

ILLUSTRATION

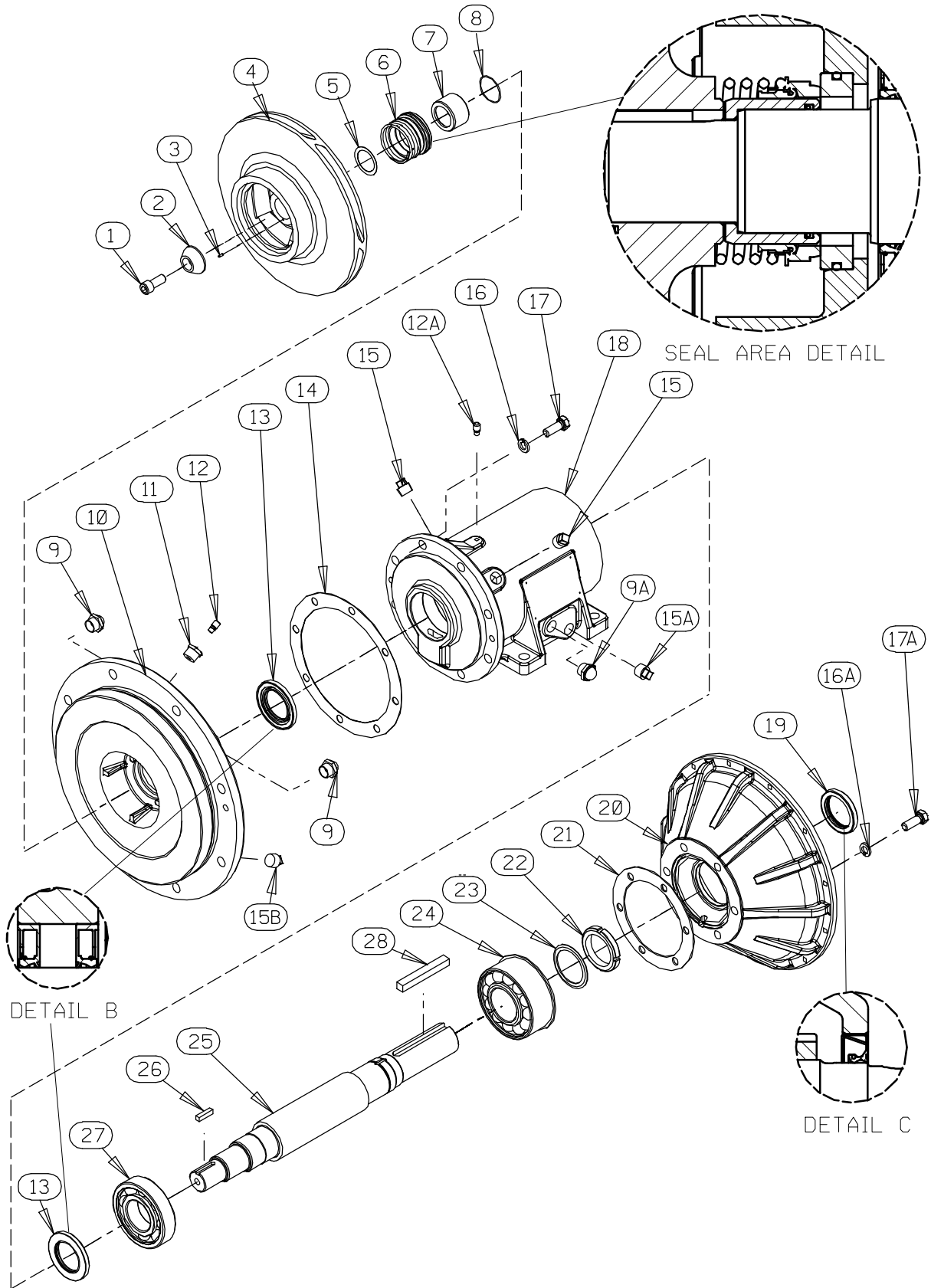

Figure 6. 44163-522 Repair Rotating Assembly

**PARTS LIST**  
**44163-522 Repair Rotating Assembly**

ITEM NO.	PART NAME	PART NUMBER	MAT'L CODE	QTY
1	SOCKET HEAD CAP SCREW	BD1006	15991	1
2	IMPELLER WASHER	31177-007	17000	1
3	ROLL PIN	S2197	----	1
4	IMPELLER	38623-533	11010	1
5	* IMP ADJ SHIM SET	8499	17000	1
6	* MECH SEAL	25285-816	----	1
7	* SHAFT SLEEVE	31441-033	17000	1
8	* O-RING	25152-138	----	1
9	SEAL CAVITY SIGHT GAUGE	S1471	----	2
9A	BEARING CAVITY SIGHT GAUGE	S1471	----	2
10	SEAL PLATE	38272-534	10000	1
11	REDUCER PIPE BUSHING	AP1202	15079	1
12	SEAL CAVITY AIR VENT	S1530	----	1
12A	BEARING CAVITY AIR VENT	S1530	----	1
13	* OIL SEAL	25227-772	----	1
13A	* OIL SEAL	25227-772	----	1
14	* GASKET	38683-665	18000	1
15	BEARING CAVITY FILL PLUG	P12	15079	2
15A	BEARING CAVITY DRAIN PLUG	P12	15079	2
15B	SEAL CAVITY DRAIN PLUG	P12	15079	1
16	LOCK WASHER	J10	15991	8
16A	LOCK WASHER	J10	15991	8
17	HEX HEAD CAP SCREW	B1007	15991	6
17A	HEX HEAD CAP SCREW	B1007	15991	6
18	PEDESTAL	38257-210	10000	1
19	* OIL SEAL	25258-845	----	1
20	DRIVE FLANGE	38545-018	10000	1
21	* GASKET	38683-664	18000	1
22	BEARING LOCKNUT	23962-015	----	1
23	BEARING LOCK WASHER	23962-515	----	1
24	BEARING	23422-417	----	1
25	IMPELLER SHAFT	38512-534	16000	1
26	* IMPELLER KEY	N0606	15990	1
27	* BALL BEARING	S1217	----	1
28	* SHAFT KEY	N1020	15990	1

## NOT SHOWN:

PUMP CASING O-RING	25152-384	----	1
SHIPPING PLUG	11495B	15079	2
INSTRUCTION TAG	6588U	----	1

\* INDICATES PARTS RECOMMENDED FOR STOCK

ILLUSTRATION

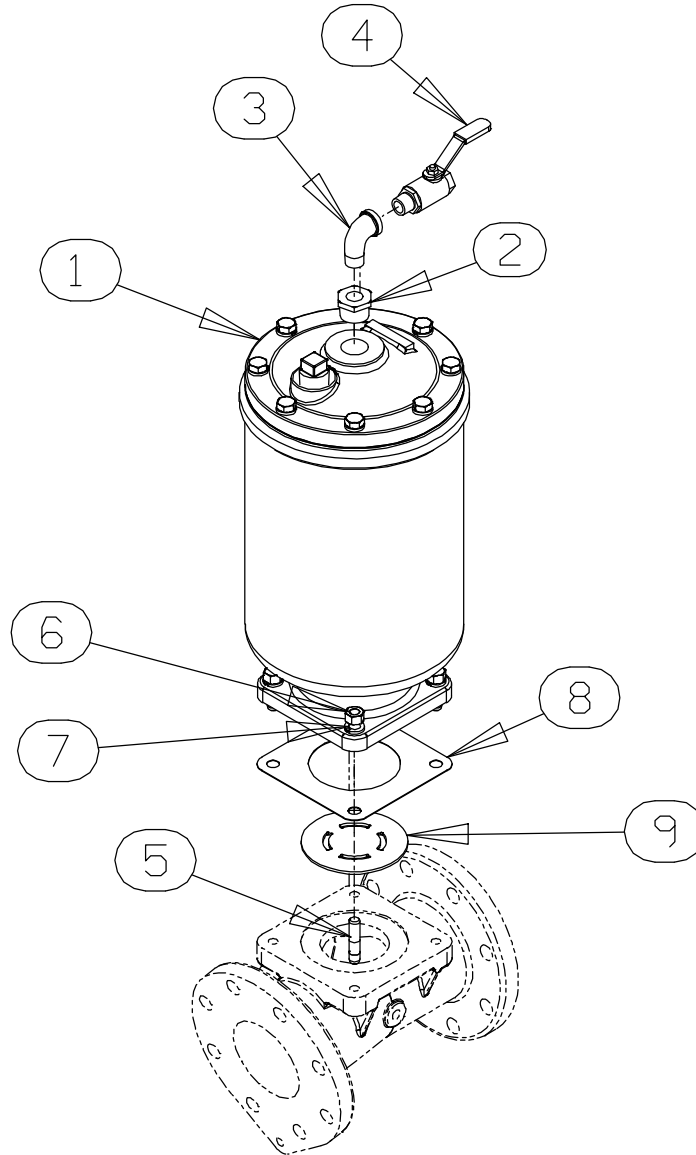

Figure 7. 48275-005 Priming Chamber Kit

ITEM NO.	PART NAME	PART NUMBER	MAT'L CODE	QTY
1	PRIMING CHAMBER ASSY	46112-709	---	1
2	PIPE BUSHING	AP1608	11999	1
3	STREET ELBOW	RS08	11999	1
4	BALL VALVE	26631-052	---	1
5	STUD	C0809	15991	4
6	HEX NUT	D08	15991	4
7	LOCK WASHER	J08	15991	4
8	* GASKET	38687-053	19060	1
9	BAFFLE	31113-011	17000	1

\* INDICATES PARTS RECOMMENDED FOR STOCK

ILLUSTRATION

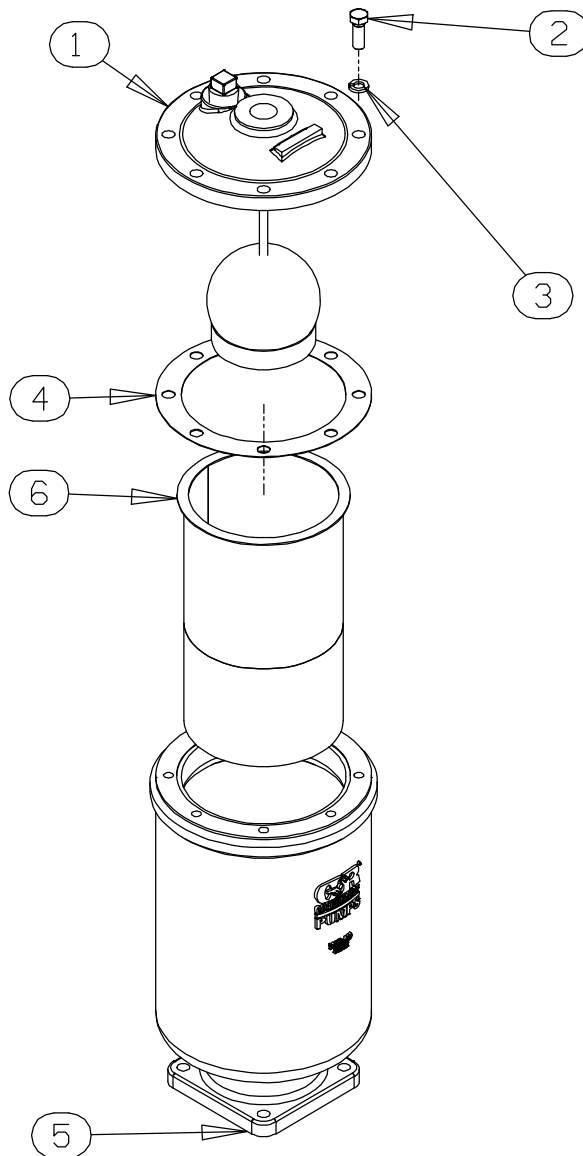

Figure 8. 46112-709 Priming Chamber Assembly

PARTS LIST

ITEM NO.	PART NAME	PART NUMBER	MAT'L CODE	QTY
1	PRIMING VALVE	26664-007	---	1
	-ORIFICE BUTTON	26688-021	---	1
2	HEX HD CAPSCREW	B0806	15991	8
3	LOCKWASHER	J08	15991	8
4	* PRIMING VALVE GASKET	38683-657	19060	1
5	PRIMING CHAMBER	38343-020	10000	1
6	STRAINER ASSY	46641-222	17000	1

\* INDICATES PARTS RECOMMENDED FOR STOCK



ILLUSTRATION

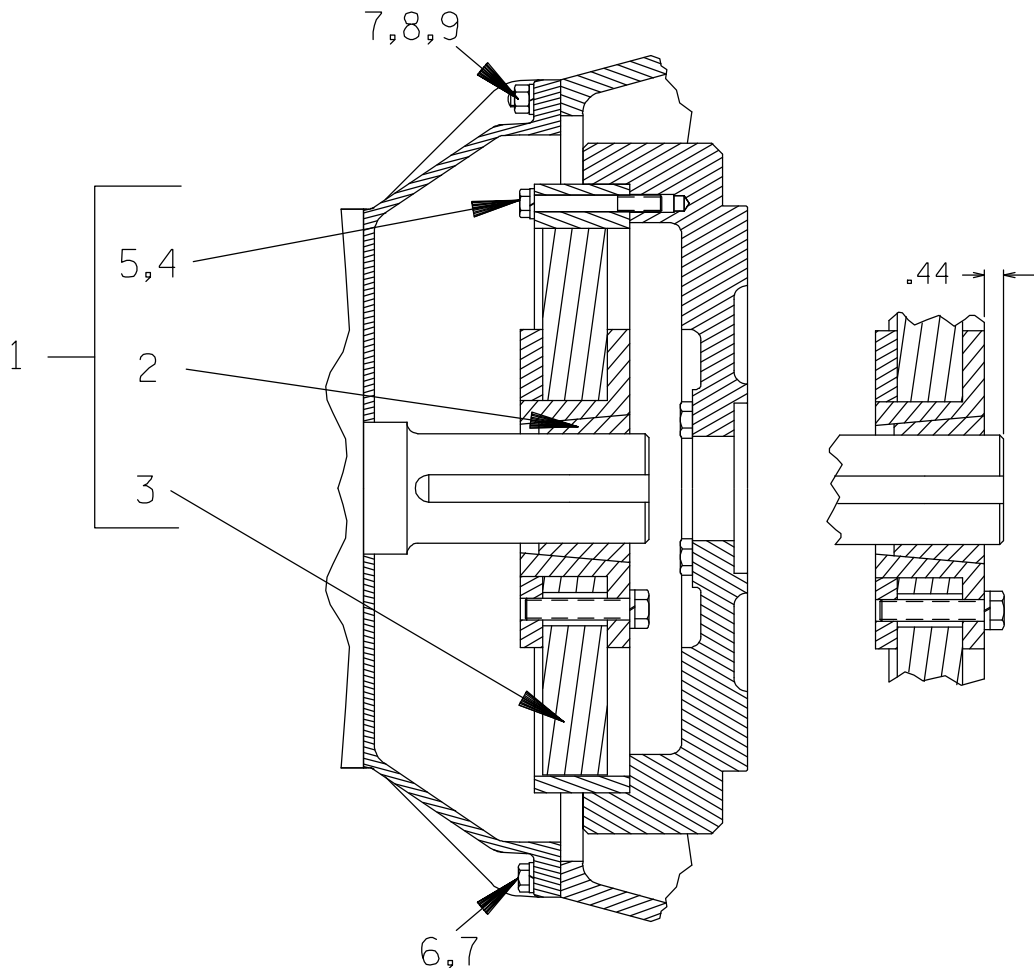













Figure 9. 44162-167 Drive Assembly

ITEM NO.	PART NAME	PART NUMBER	MAT'L CODE	QTY
1	COUPLING KIT	48112-011	---	1
2	-BUSHING	24131-492	---	1
3	-COUPLING ASSEMBLY	24391-107	---	1
4	LOCKWASHER	21171-536	---	8
5	 HEX HEAD CAPSCREW	B0612	15991	8
5	 HEX HEAD CAPSCREW	22645-174	---	8
6	 HEX HEAD CAPSCREW	B0606	15991	10
6	 HEX HEAD CAPSCREW	22645-166	---	10
7	 LOCKWASHER	J06	15991	12
7	 LOCKWASHER	21171-511	---	12
8	 STUD	C0606	15991	2
8	 STUD	26821-879	15991	2
9	 HEX NUT	D06	15991	2
9	 HEX NUT	26821-932	---	2
	 USE FOR SAE APPLICATIONS			
	 USE FOR METRIC APPLICATIONS			