

SECTION DRAWING

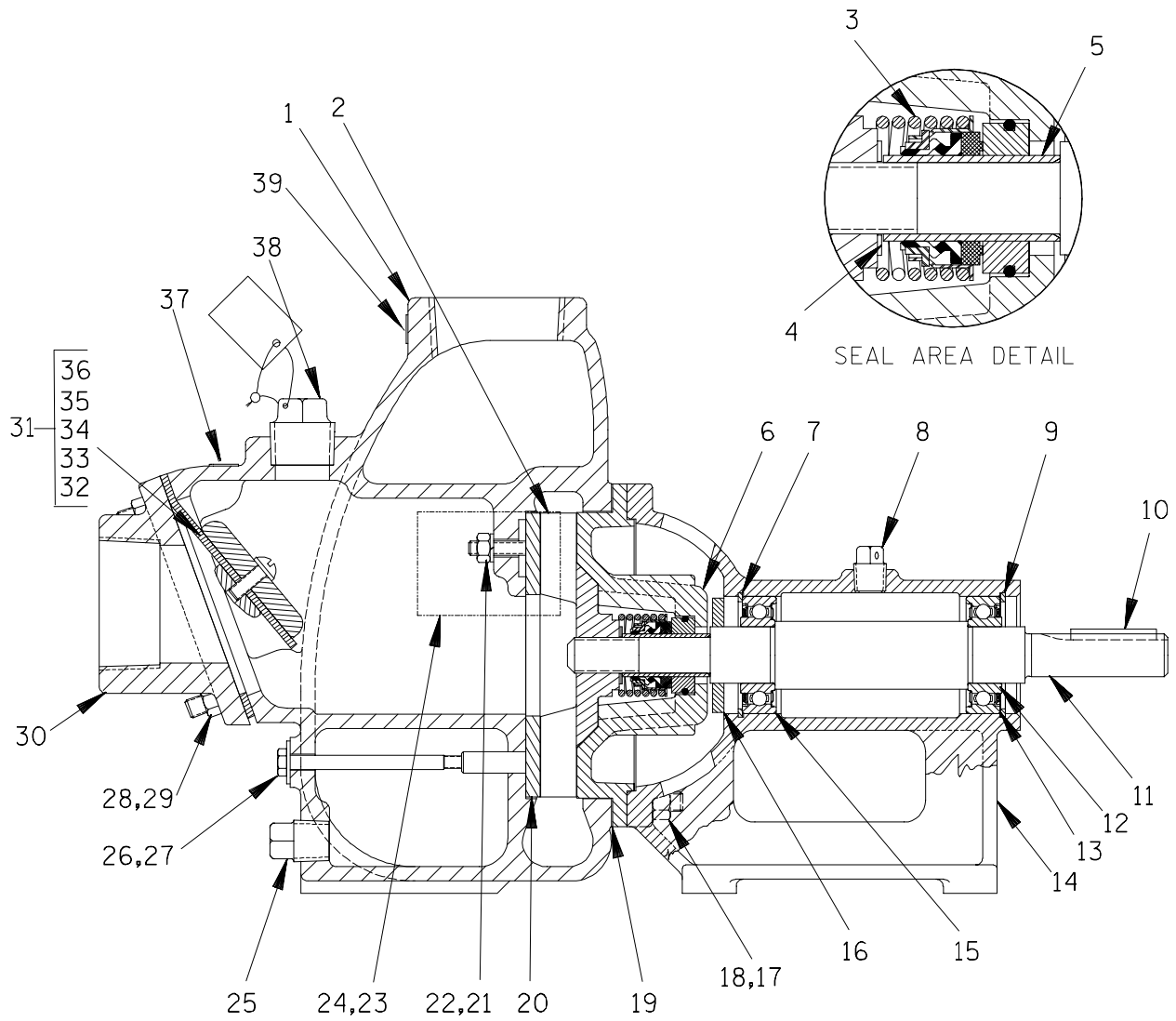

Figure 1. Pump Model 82D3-B

PARTS LIST
Pump Model 82D3-B
 (From S/N 274955 up)

If your pump serial number is followed by an "N", your pump is **NOT** a standard production model. Contact the Gorman-Rupp Company to verify part numbers.

ITEM NO.	PART NAME	PART NUMBER	MAT'L CODE	QTY
1	PUMP CASING	6846C	10010	1
2	* IMPELLER	2912F	10010	1
3	* SEAL ASSEMBLY	S33	---	1
4	* IMPELLER ADJ SHIM SET	513A	17090	1
5	* SHAFT SLEEVE	2353	17020	1
6	SEAL PLATE	2930A	10010	1
7	BEARING RETAINING RING	S240	---	1
8	VENTED PIPE PLUG	4823	15079	1
9	BEARING RETAINING RING	S240	---	1
10	* SHAFT KEY	N0306	15990	1
11	IMPELLER SHAFT	2931	15000	1
12	* OUTBOARD BALL BEARING	S1085	---	1
13	BEARING ADJ SHIM SET	8540	15990	1
14	PEDESTAL	2928	10010	1
15	* INBOARD BALL BEARING	S1085	---	1
16	SLINGER RING	3228	19120	1
17	STUD	C0607	15991	4
18	HEX NUT	D06	15991	4
19	* CASING GASKET SET	504GA	20000	1
20	* WEAR PLATE ASSY	2643A	15990	1
21	LOCKWASHER	J04	15991	1
22	HEX NUT	D06	15991	1
23	NAME PLATE	38812-041	13990	1
24	DRIVE SCREW	BM#04-03	17000	4
25	PIPE PLUG	P08	15079	1
26	HEX HD CAPSCREW	B0414	15991	1
27	FLAT WASHER	KF04	18040	1
28	STUD	C0606	15991	4
29	HEX NUT	D06	15991	4
30	SUCTION FLANGE	1361	10010	1
31	FLAP VALVE ASSY	1361A	---	1
32	-SMALL VALVE WEIGHT	1354	15160	1
33	* -CHECK VALVE GASKET	1361G	19070	1
34	-LARGE VALVE WEIGHT	19B	10010	1
35	-RD HD MACH SCREW	X0403	17090	1
36	-LOCKWASHER	J04	17090	1
37	SUCTION STICKER	6588AG	---	1
38	FILL PLUG ASSY	48271-062	---	1
39	DISCHARGE STICKER	6588BJ	---	1

NOT SHOWN:

G-R DECAL	GR-03	---	1
ROTATION DECAL	2613M	---	1
LUBE DECAL	38816-075	---	1
INSTRUCTION TAGS	38817-011	---	1
INSTRUCTION TAGS	38817-020	---	1
PRIMING STICKER	6588AH	---	1

* INDICATES PARTS RECOMMENDED FOR STOCK