

SECTION DRAWING

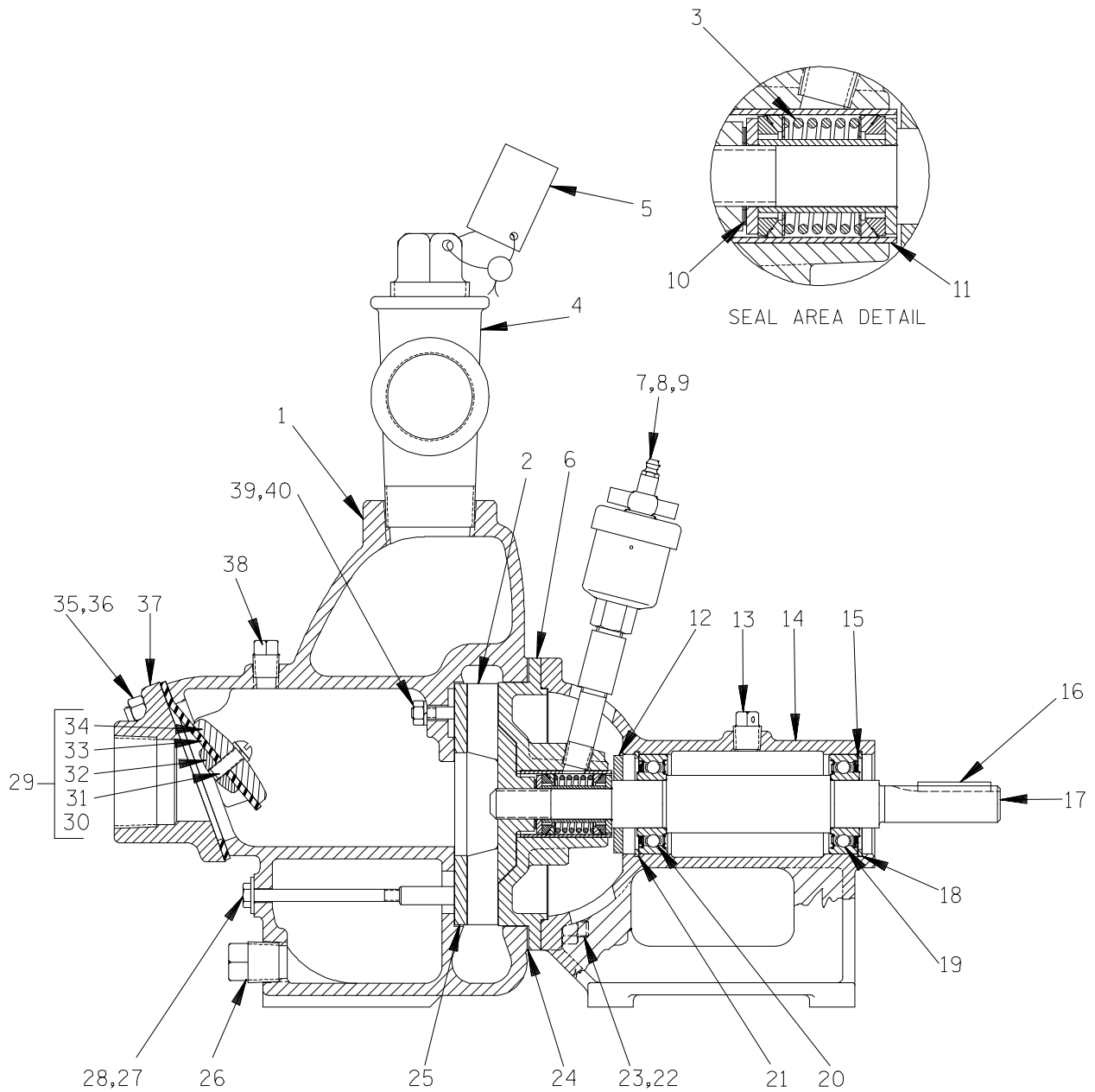

Figure 1. Pump Model 81 1/2A2-B

PARTS LIST
Pump Model 81 1/2A2-B
 (From S/N 253703 up)

If your pump serial number is followed by an "N", your pump is **NOT** a standard production model. Contact the Gorman-Rupp Company to verify part numbers.

ITEM NO.	PART NAME	PART NUMBER	MAT'L CODE	QTY
1	PUMP CASING	6846B	10010	1
2	* IMPELLER	2912B	10010	1
3	* GREASE SEAL ASSEMBLY	GS625	----	1
4	SERVICE TEE	US24	11999	1
5	FILL PLUG ASSY	48271-066	----	1
6	SEAL PLATE	2929	10010	1
7	GREASE CUP	S36	----	1
8	PIPE COUPLING	AE04	15079	1
9	PIPE NIPPLE	T0408	15079	1
10	IMPELLER ADJUSTING SHIM SET	513A	17090	1
11	SEAL LINER	1904	14080	REF
12	SLINGER RING	3228	19120	1
13	VENTED PIPE PLUG	4823	15079	1
14	PEDESTAL	2928	10010	1
15	BEARING ADJ SHIM SET	8540	15990	1
16	* SHAFT KEY	N0306	15990	1
17	* IMPELLER SHAFT	2931	15000	1
18	BEARING RETAINING RING	S240	----	1
19	* OUTBOARD BALL BEARING	S1085	----	1
20	* INBOARD BALL BEARING	S1085	----	1
21	BEARING RETAINING RING	S240	----	1
22	HEX NUT	D06	15991	4
23	STUD	C0607	15991	4
24	* CASING GASKET SET	504GA	20000	1
25	* WEAR PLATE ASSY	2643A	15990	1
26	PUMP CASING DRAIN PLUG	P08	15079	1
27	HEX HD CAPSCREW	B0414	15991	1
28	FLAT WASHER	KF04	18040	1
29	FLAP VALVE ASSY	1352	----	1
30	-RD HD MACH SCREW	X0403	17090	1
31	-LOCKWASHER	J04	17090	1
32	-SMALL VALVE WEIGHT	1354	15160	1
33	* -CHECK VALVE GASKET	1352G	19070	1
34	-LARGE VALVE WEIGHT	1353	10010	1
35	STUD	C0607	15991	4
36	HEX NUT	D06	15991	4
37	SUCTION FLANGE	8599	10010	1
38	PIPE PLUG	P04	15079	1
39	LOCKWASHER	J04	15991	1
40	HEX NUT	D04	15991	1
NOT SHOWN:	SUCTION STICKER	6588AG	----	1
	PRIMING STICKER	6588AH	----	1
	DISCHARGE STICKER	6588BJ	----	1
	GREASE CUP INSTRUCTIONS	6588BD	----	1
	ROTATION DECAL	2613M	----	1
	G-R DECAL	GR-03	----	1
	LUBE DECAL	38816-075	----	1
	NAMEPLATE	38812-041	13990	1
	DRIVE SCREW	BM#04-03	17000	4
	INSTRUCTION TAG	38817-011	----	1
	INSTRUCTION TAG	38817-020	----	1

* INDICATES PARTS RECOMMENDED FOR STOCK