



Self Priming Centrifugal Pump



Model V3C60SC-B

Size 4" x 3"



VARIOUS PATENTS APPLY

PUMP SPECIFICATIONS

Size: 4" x 3" (101,6 mm x 76,2 mm).**

Casing: Gray Iron 30.

Maximum Operating Pressure 127 psi (876 kPa).*

Semi-Open Type, Two Vane Impeller: Ductile Iron 65-45-12.

Handles 2.50" (63,5 mm) Diameter Spherical Solids.

Impeller Shaft: Alloy Steel 4150.

Replaceable Eradicator Wear Plate: Carbon Steel ASTM A36.

Removable Adjustable Cover Plate: Gray Iron 30.

Removable Inspection Cover Plate: Gray Iron 30.

Externally Removable Flap Valve: Neoprene w/Nylon and Steel Reinforcing.

Suction Flange/Flap Valve Seat: Gray Iron 30.

Bearing Housing: Gray Iron 30.

Seal Plate: Gray Iron 30.

Shaft Sleeve: Alloy Steel 4130.

Radial and Thrust Bearings: Open Double Row Ball.

Bearing and Seal Cavity Lubrication: SAE 30 Non-Detergent Oil.

Gaskets: Buna-N, Compressed Synthetic Fibers, Vegetable Fiber, PTFE, Cork and Rubber.

O-Rings: Buna-N.

Hardware: Standard Plated Steel.

Brass Pressure Relief Valve.

Bearing and Seal Cavity Oil Level Sight Gauges.

Optional Equipment: Automatic Air Release Valve. High Pump Temperature Shutdown Kit. Cartridge Seal w/Stainless Steel Sleeve. 120/240 Volt Casing Heater.

** Optional Gray Iron 30 Flanges Available as Follows (See Price Sheets):

4" and 3" Female NPT Suction/Discharge Flange Kits.

4" and 3" ASA Suction/Discharge Spool Flange Kits.

200 mm and 150 mm DIN 2527 (PN 16) Suction/Discharge Spool Flange Kits.

PHOTO NOT AVAILABLE AT TIME OF PUBLISHING

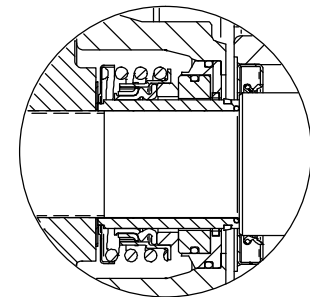
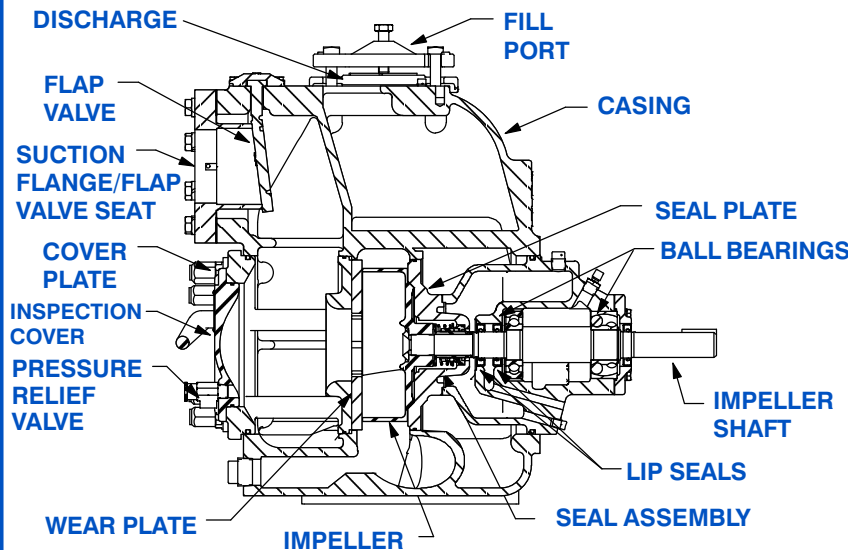

SEAL DETAIL

Cartridge Type, Mechanical, Oil-Lubricated, Double Floating, Self-Aligning. Silicon Carbide Rotating and Stationary Faces. Stainless Steel 316 Stationary Seat. Fluorocarbon Elastomers (DuPont Viton® or Equivalent). Stainless Steel 18-8 Cage and Spring. Maximum Temperature of Liquid Pumped, 160°F (71°C).*

*** Consult Factory for Applications Exceeding Maximum Pressure and/or Temperature Indicated.**



GORMAN-RUPP PUMPS

www.grpumps.com

Specifications Subject to Change Without Notice

Printed in U.S.A.

Specification Data

SECTION 55, PAGE 2525

APPROXIMATE DIMENSIONS and WEIGHTS

NET WEIGHT: 650 LBS. (295 KG.)*
SHIPPING WEIGHT: 700 LBS. (317 KG.)*
EXPORT CRATE: 13.5 CU. FT. (0,38 CU. M.)
***WEIGHTS DO NOT INCLUDE OPTIONAL FLANGE KITS.**

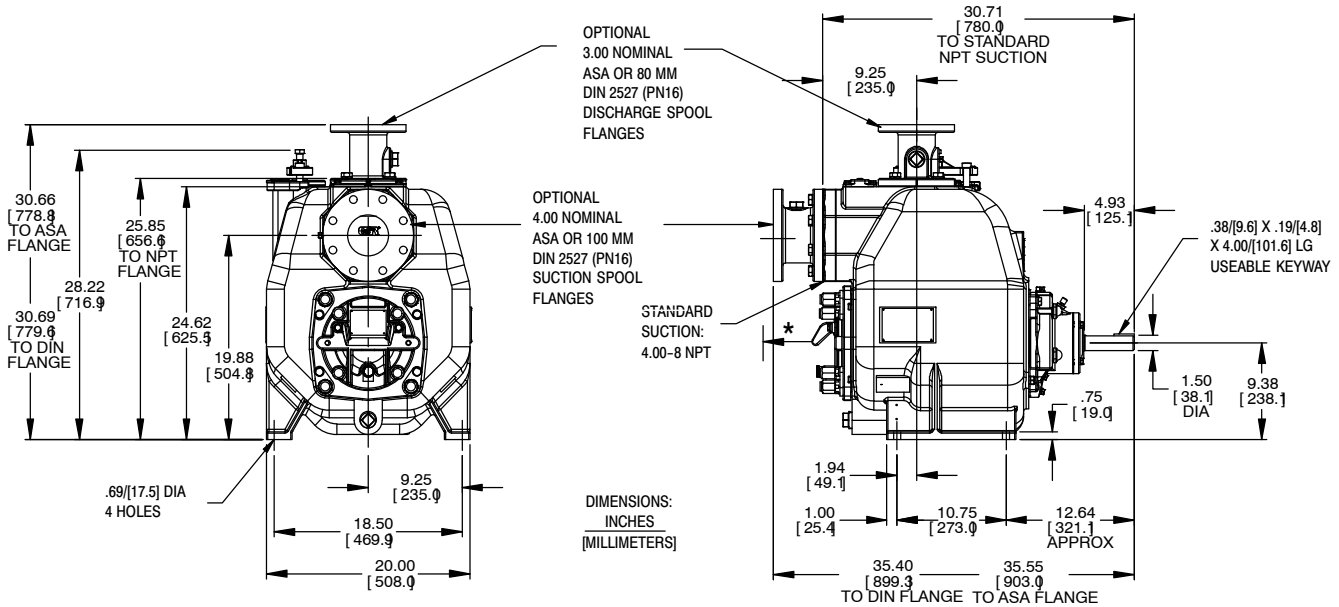

* 18.00/[457.2] RECOMMENDED FOR REMOVAL OF BACK COVER PLATE
 10.50/[266.7] REQUIRED FOR REMOVAL OF BACK COVER PLATE

60 HERTZ PERFORMANCE BASED ON WATER

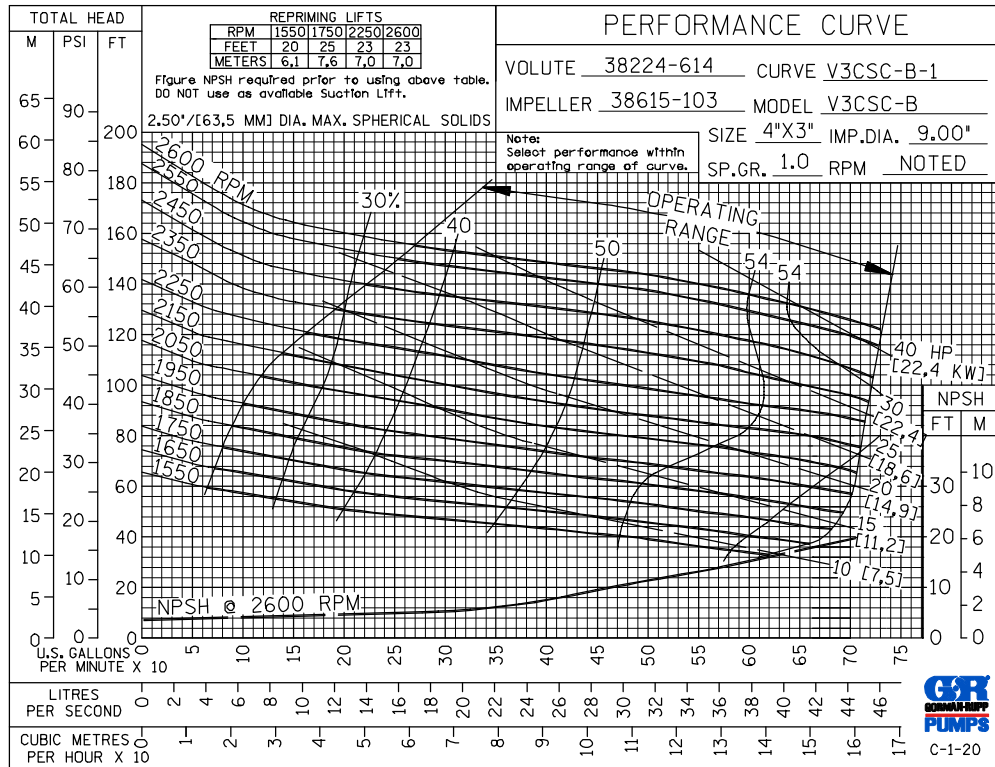

GORMAN-RUPP PUMPS

www.grpumps.com

Specifications Subject to Change Without Notice

Printed in U.S.A.

**60 HERTZ
PERFORMANCE
FOR REDUCED
SUCTION
BASED ON
WATER**

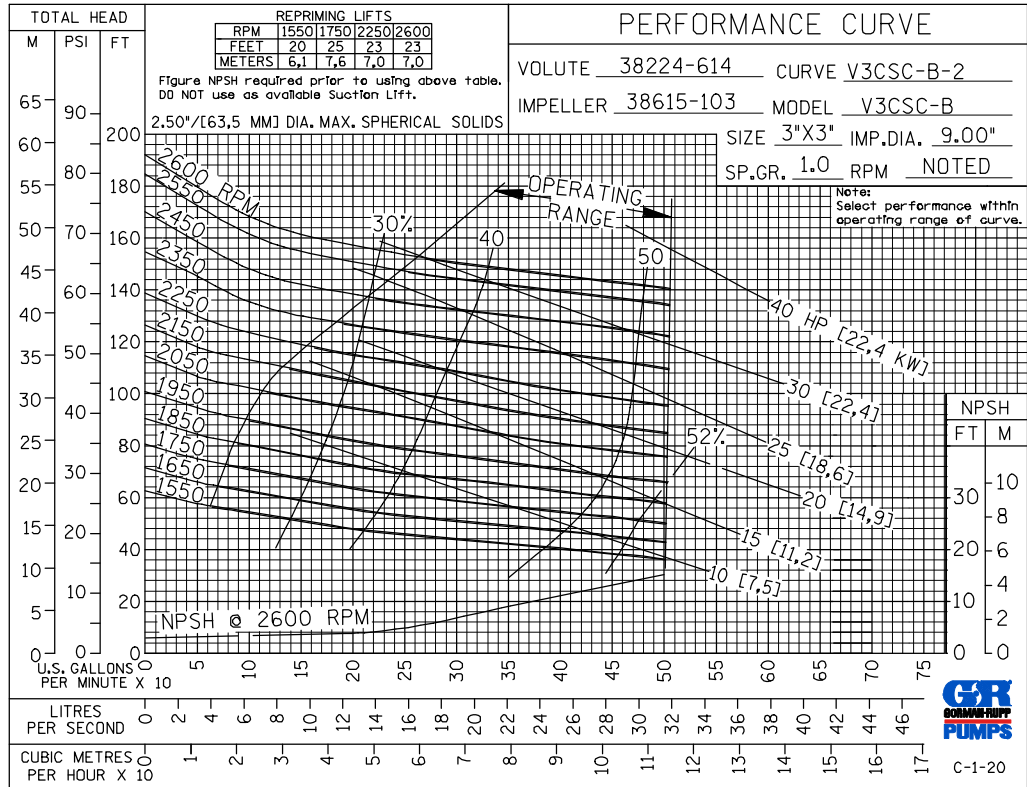

**60 HERTZ
PERFORMANCE
BASED ON
WATER**

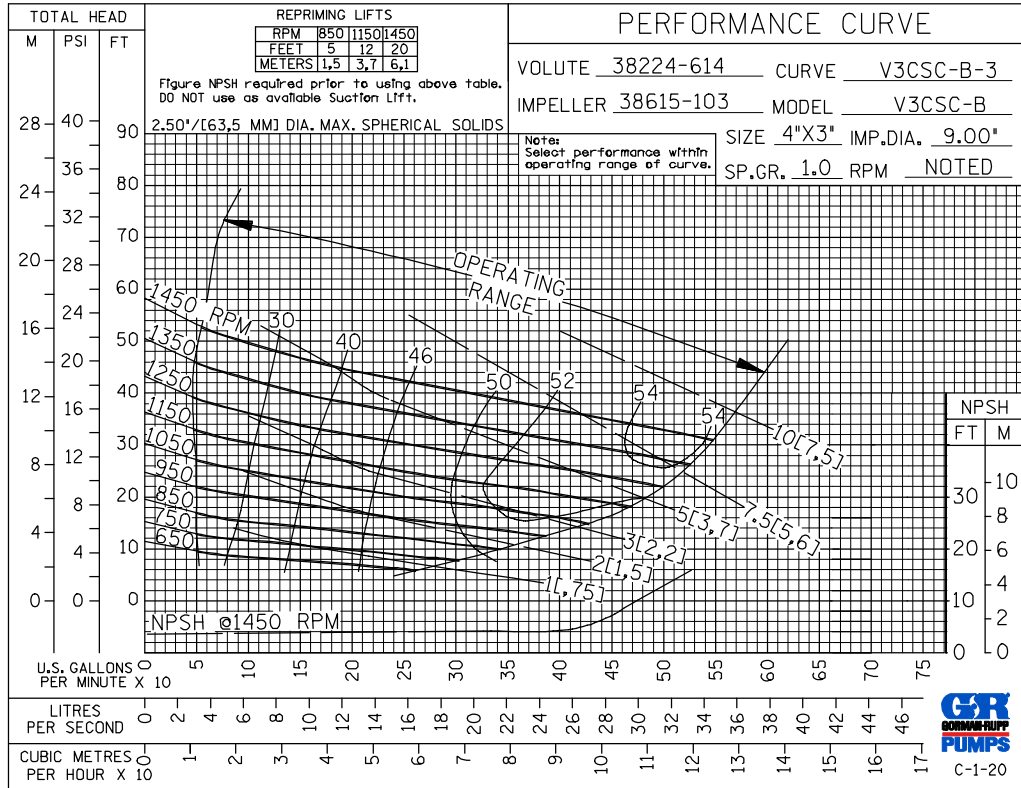

**60 HERTZ
PERFORMANCE
BASED ON
WATER
TRIMMED
IMPELLER**

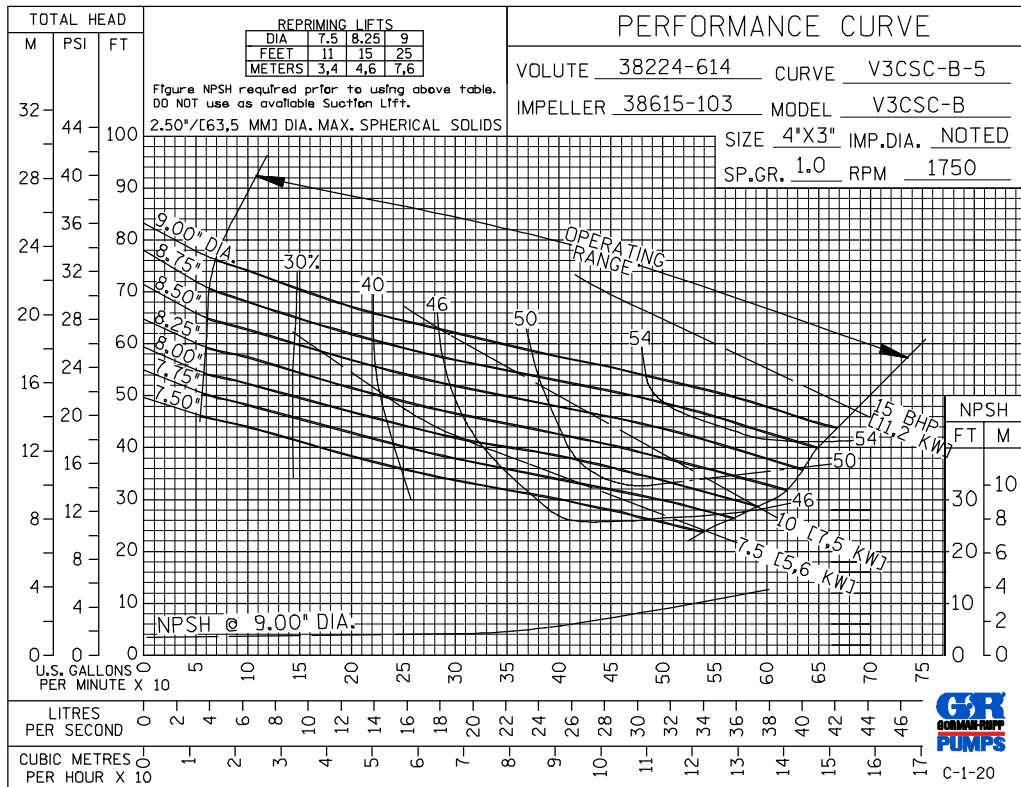

GORMAN-RUPP PUMPS

www.grpumps.com

Specifications Subject to Change Without Notice

Printed in U.S.A.

**60 HERTZ
PERFORMANCE
BASED ON
WATER**

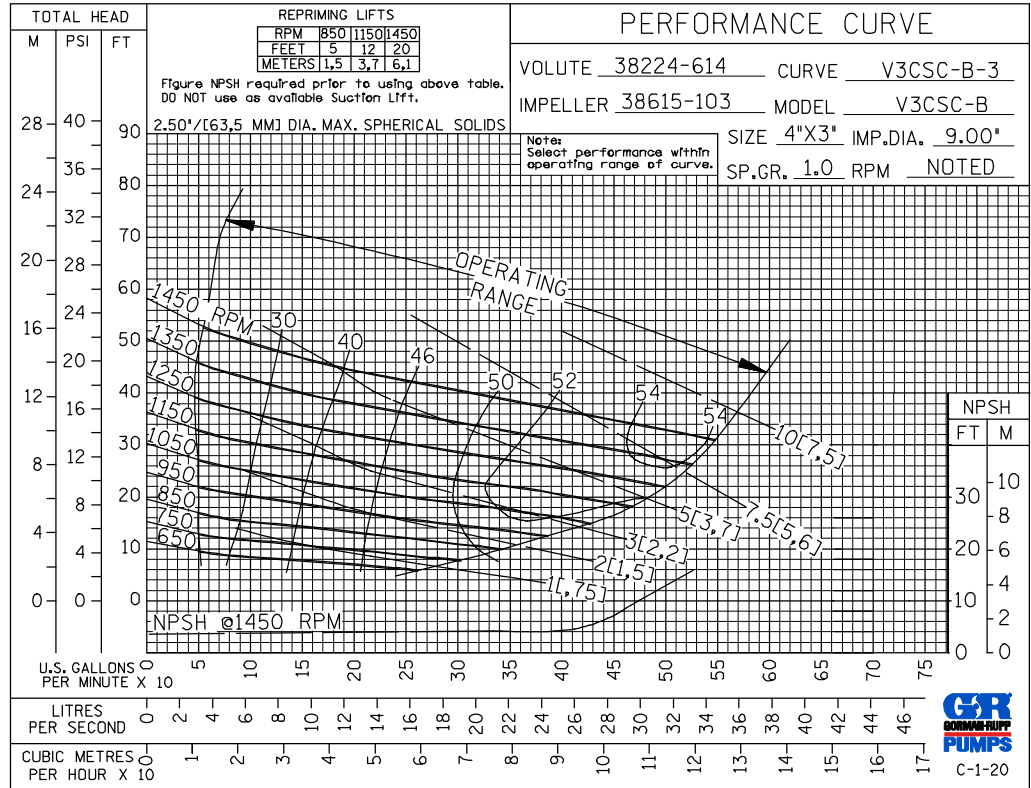

**60 HERTZ
PERFORMANCE
BASED ON
WATER
TRIMMED
IMPELLER**

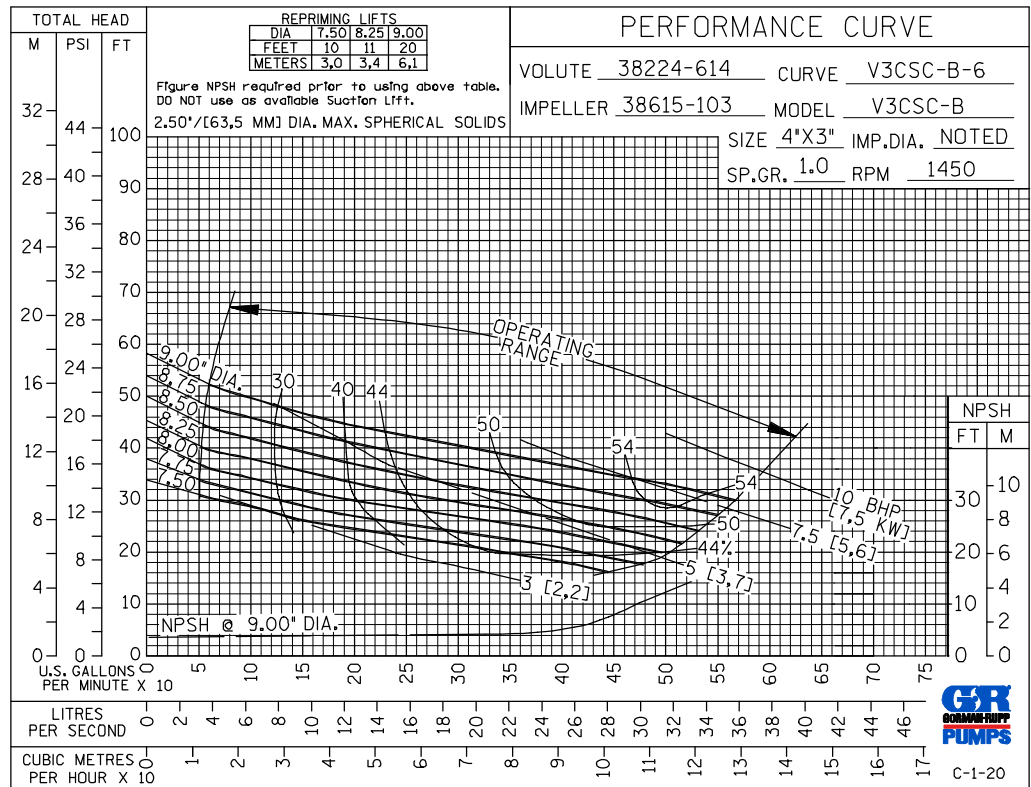

GORMAN-RUPP PUMPS

www.grpumps.com

Specifications Subject to Change Without Notice

Printed in U.S.A.