

Self Priming Centrifugal Pump

ULTRA
SERIES

VARIOUS PATENTS APPLY

Model V3B60-B
Size 4" x 3"

PUMP SPECIFICATIONS
Size: 4" x 3" (102 mm x 76 mm).**

Casing: Gray Iron 30.

Maximum Operating Pressure 90 psi (621 kPa).*

Semi-Open Type, Two Vane Impeller: Ductile Iron 65-45-12.

Handles 3" (76,2 mm) Diameter Spherical Solids.

Impeller Shaft: Stainless Steel 17-4 PH.

Self-Cleaning Replaceable Wear Plate: Carbon Steel ASTM A36.

Adjustable Back Cover Plate: Gray Iron 30.

Removable Inspection Cover Plate: Gray Iron 30; 12 lbs. (5,4 kg.).

Externally Removable Flap Valve: Neoprene w/Nylon and Steel Reinforcing.

Suction Flange/Flap Valve Seat: Gray Iron 30.

Bearing Housing: Gray Iron 30.

Seal Plate: Gray Iron 30.

Shaft Sleeve: Alloy Steel 4130.

Radial Bearing: Open Single Row Ball.

Thrust Bearing: Open Double Row Ball.

Bearing and Seal Cavity Lubrication: SAE 30 Non-Detergent Oil.

Gaskets: Buna-N, Compressed Synthetic Fibers, Vegetable Fiber, PTFE, Cork and Rubber.

O-Rings: Buna-N.

Hardware: Standard Plated Steel.

Brass Pressure Relief Valve.
Bearing and Seal Cavity Oil Level Sight Gauges.
Optional Equipment: Automatic Air Release Valve. High Pump Temperature Shutdown Kit. Stainless Steel/G-R Hard Iron Impeller, Seal Plate and Wear Plate. Cartridge Seal w/Stainless Steel Sleeve. 120/240 Volt Casing Heater.

** Optional Gray Iron 30 Flanges Available as Follows (See Price Sheets):

3" Female NPT Discharge Flange Kit.

4" and 3" ASA Suction/Discharge Spool Flange Kits.

100 mm and 80 mm DIN 2527 (PN 16) Suction/Discharge Spool Flange Kits.

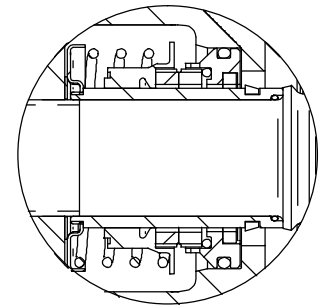
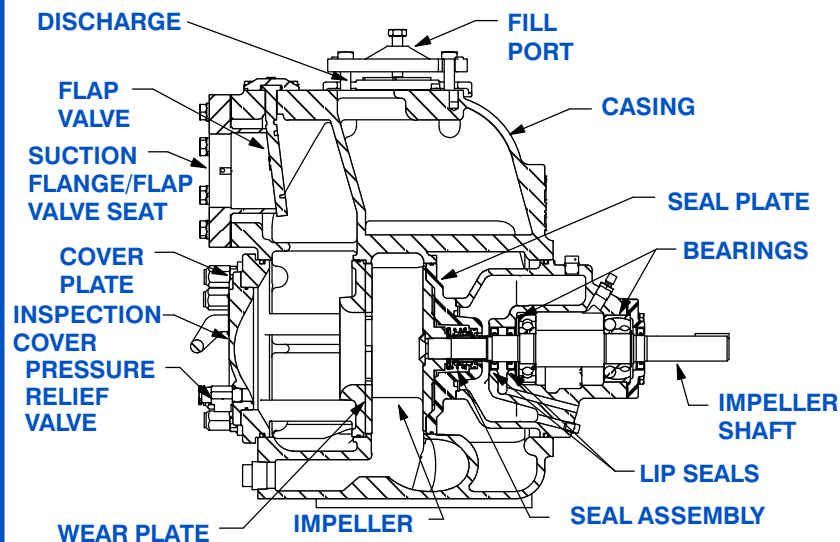
SEAL DETAIL

Cartridge Type, Mechanical, Oil-Lubricated, Double Floating, Self-Aligning. Silicon Carbide Rotating and Stationary Faces. Stainless Steel 316 Stationary Seat. Fluorocarbon Elastomers (DuPont Viton® or Equivalent). Stainless Steel 18-8 Cage and Spring. Maximum Temperature of Liquid Pumped, 160°F (71°C).*

*** Consult Factory for Applications Exceeding Maximum Pressure and/or Temperature Indicated.**

GORMAN-RUPP
PUMPS

GORMAN-RUPP PUMPS
www.grpumps.com

Specifications Subject to Change Without Notice

Printed in U.S.A.

Specification Data

NET WEIGHT: 640 LBS. (290 KG.)*
SHIPPING WEIGHT: 690 LBS. (313 KG.)*
EXPORT CRATE: 13.5 CU. FT. (0,38 CU. M.)
 *WEIGHTS DO NOT INCLUDE OPTIONAL FLANGE KITS.

SECTION 55, PAGE 2550

APPROXIMATE DIMENSIONS and WEIGHTS

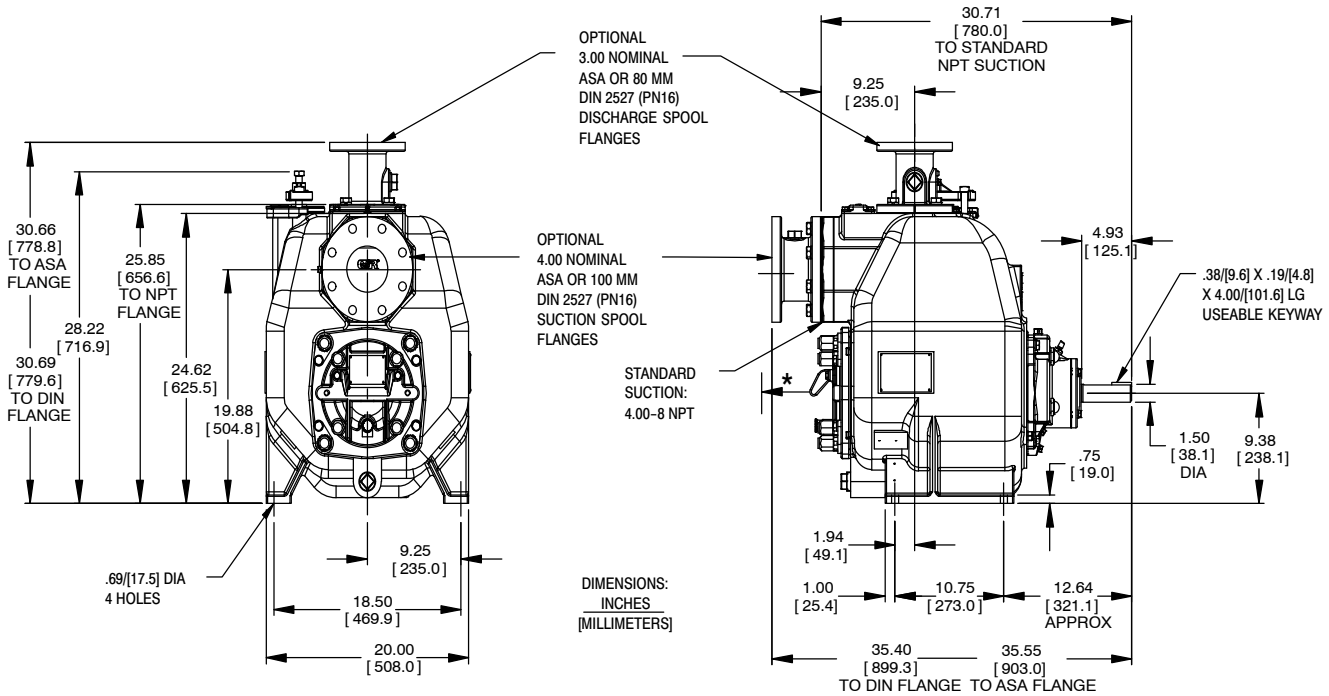

* 18.00/[457.2] RECOMMENDED FOR REMOVAL OF BACK COVER PLATE
 10.50/[266.7] REQUIRED FOR REMOVAL OF BACK COVER PLATE

60 HERTZ PERFORMANCE BASED ON WATER

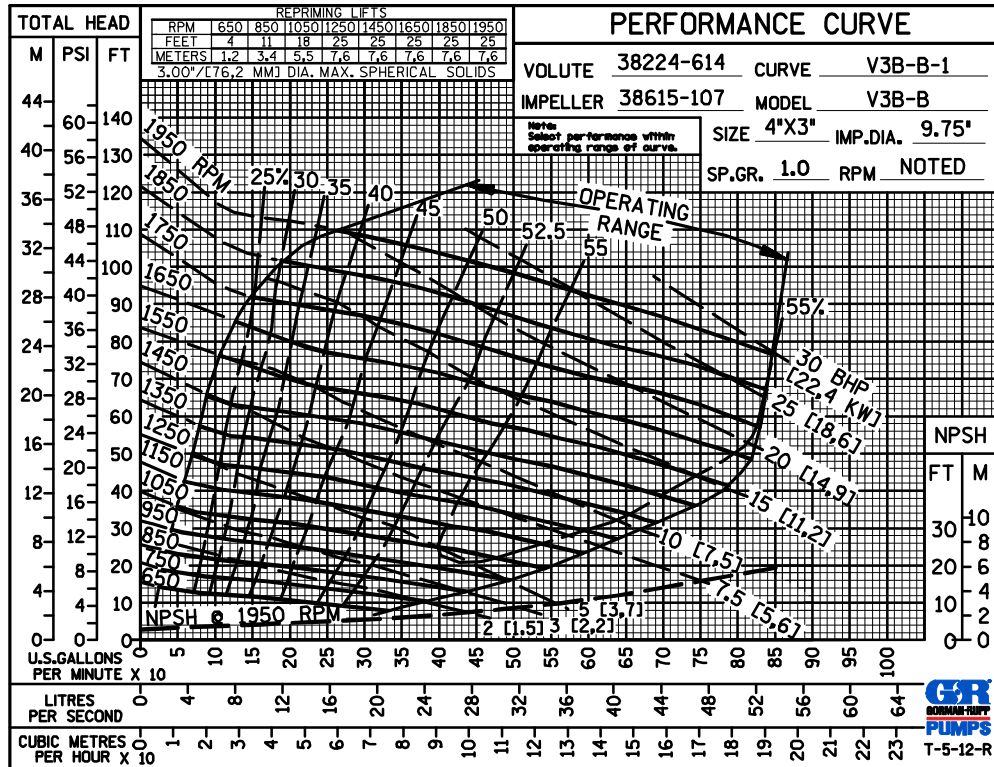

GORMAN-RUPP PUMPS

www.grpumps.com

Specifications Subject to Change Without Notice

Printed in U.S.A.

60 HERTZ
PERFORMANCE
BASED ON
WATER
TRIMMED
IMPELLER

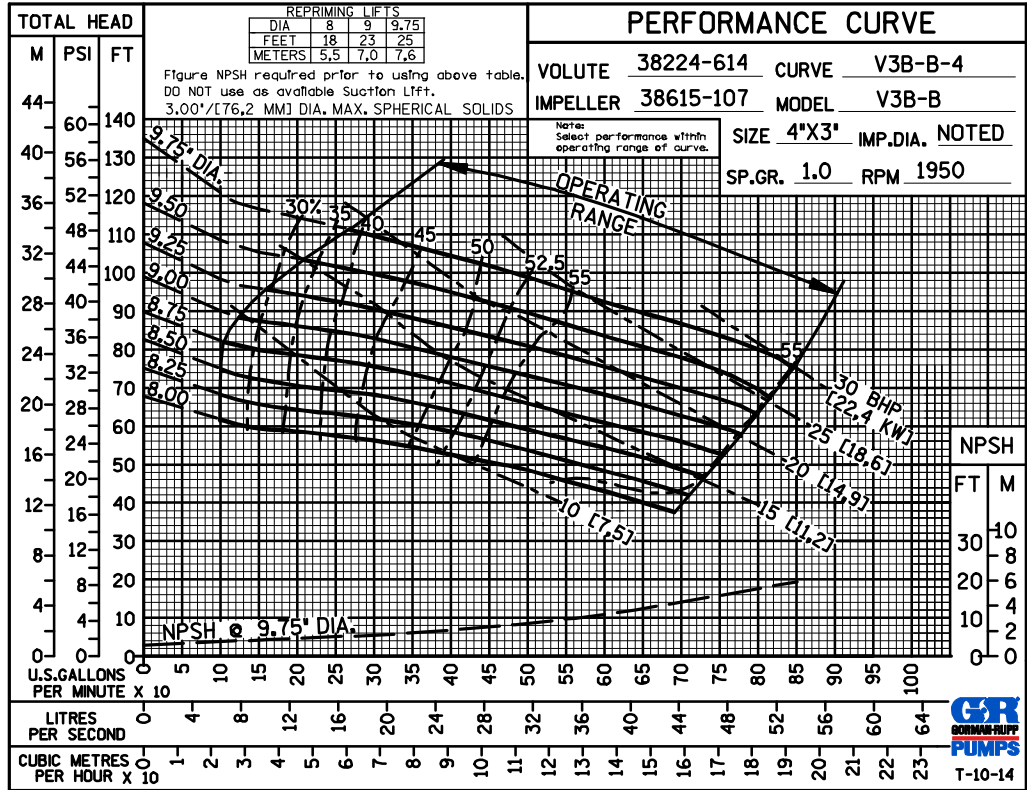

60 HERTZ
PERFORMANCE
BASED ON
WATER
TRIMMED
IMPELLER

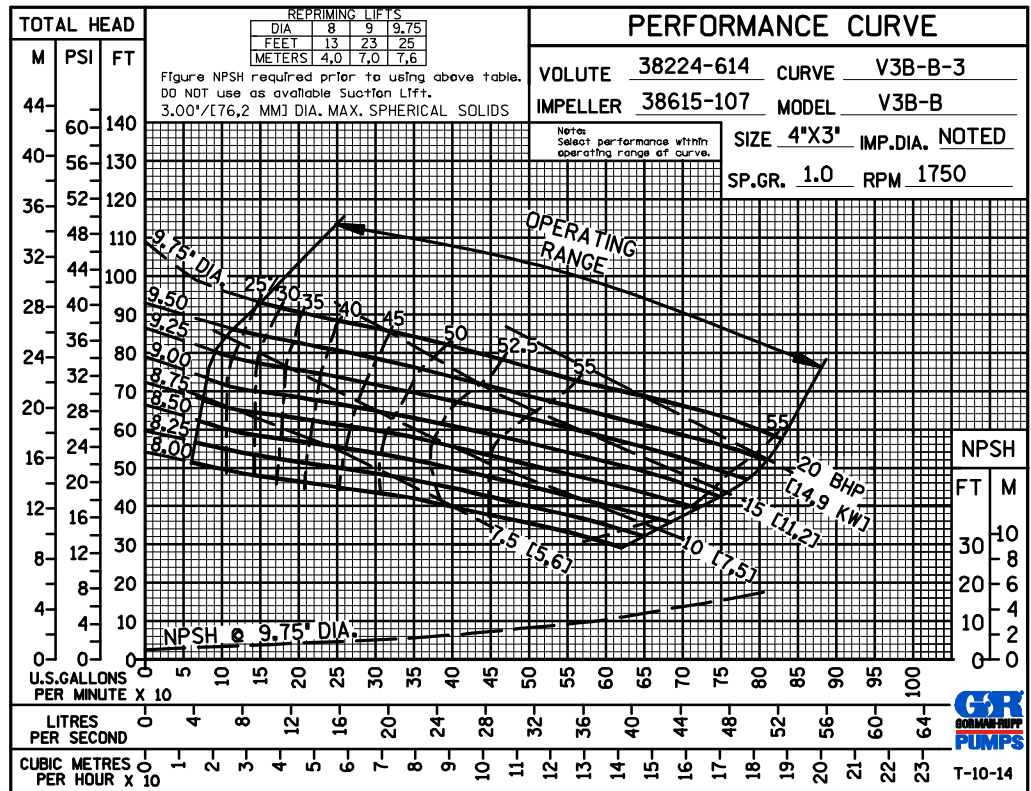

GORMAN-RUPP PUMPS

www.grpumps.com

Specifications Subject to Change Without Notice

Printed in U.S.A.

60 HERTZ
PERFORMANCE
FOR REDUCED
SUCTION
BASED ON
WATER

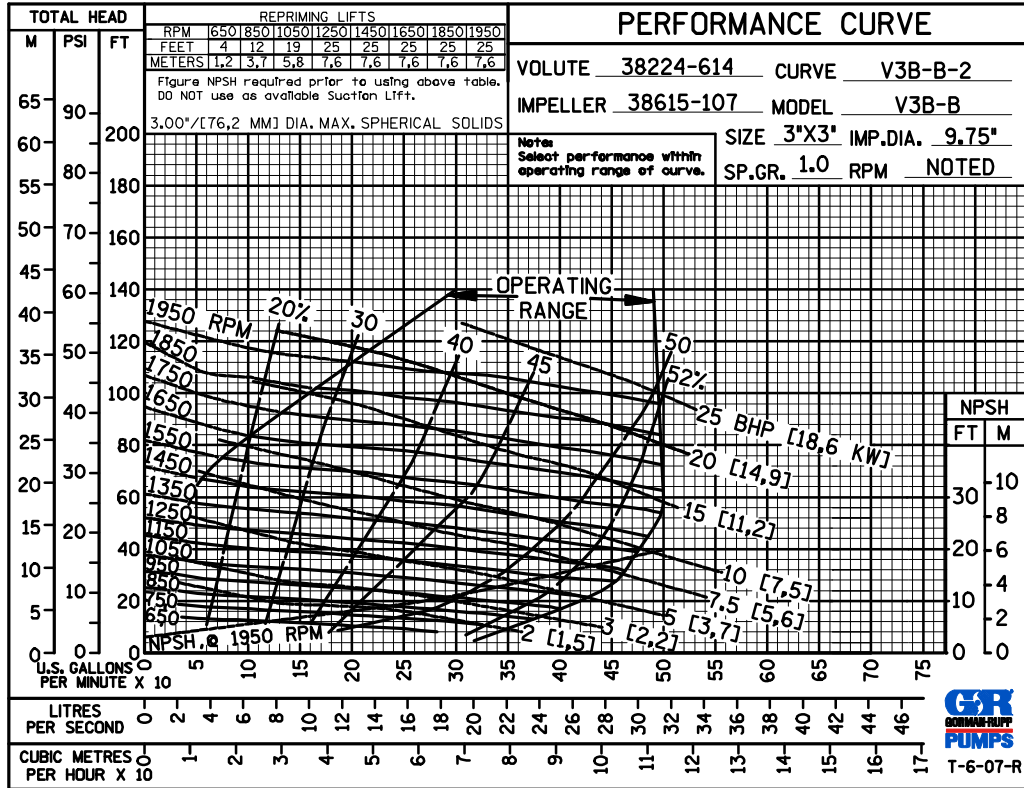

50 HERTZ
PERFORMANCE
BASED ON
WATER

 TRIMMED
IMPELLER

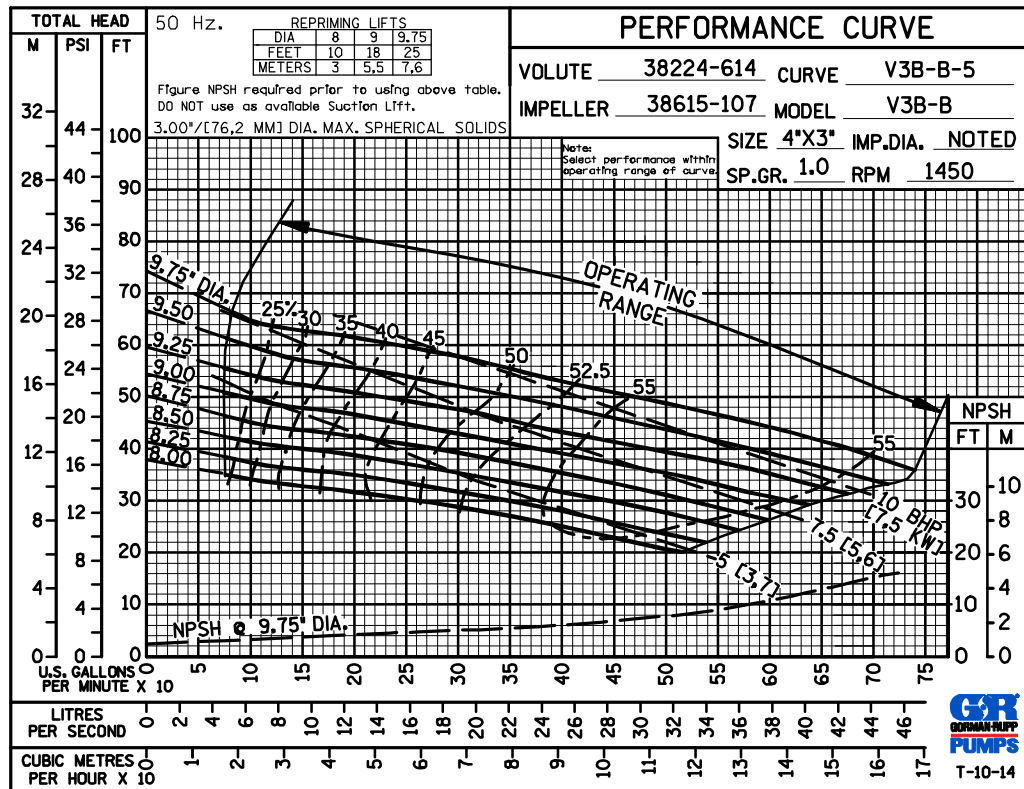

GORMAN-RUPP PUMPS

www.grpumps.com

Specifications Subject to Change Without Notice

Printed in U.S.A.