



VARIOUS PATENTS APPLY

Priming Assisted Centrifugal Pump w/Autostart

Model PA6D60-4045T FT4

Size 6" x 6"



Total Head		Capacity of Pump in U.S. Gallons per Minute (GPM) at Continuous Performance				
P.S.I.	Feet					
61.5	142	555	555	555	555	555
60.7	140	600	600	600	600	600
52.0	120	995	1230	1230	1230	1230
43.4	100	1015	1435	1720	1820	1820
34.7	80	1030	1440	1760	2030	2260
26.0	60	1045	1455	1770	2040	2285
17.4	40	1060	1460	1780	2050	2320
Suction Lift		25'	20'	15'	10'	5'

PUMP SPECIFICATIONS

Size: 6 x 6" (152 mm x 152 mm) Flanged.

Casing: Gray Iron 30.

Maximum Operating Pressure 103 psi (710 kPa).*

Enclosed Type, Two Vane Impeller: Ductile Iron 65-45-12.

Handles 3" (76.2 mm) Diameter Spherical Solids.

Suction Spool: Gray Iron 30.

Impeller Shaft: Stainless Steel 17-4 PH.

Externally Adjustable Wear Plate: Carbon Steel C1015.

Bearing Housing: Gray Iron 30.

Seal Plate: Gray Iron 30.

Seal: Mechanical, Oil-Lubricated. Silicon Carbide Rotating Face. Silicon Carbide Stationary Seat. Fluorocarbon Elastomers (DuPont Viton® or Equivalent). Stainless Steel 18-8 Cage and Spring. Maximum Temperature of Liquid Pumped, 160°F (71°C).*

Shaft Sleeve: Stainless Steel 17-4 PH.

Priming Chamber: Gray Iron 30 Housing w/Stainless Steel Float and Linkage.

Discharge Check Valve: Ductile Iron Housing w/Buna-N Flapper.

Radial/Thrust Bearings: Open Double Ball.

Bearing and Seal Cavity Lubrication: SAE 30 Non-Detergent Oil.

Gaskets: Resistant Synthetic Rubber, Cork, PTFE, Vegetable Fiber, and Compressed Synthetic Fibers.

O-Rings: Buna-N.

Hardware: Standard Plated Steel.

Bearing and Seal Cavity Oil Level Sight Gauges.

*Consult Factory for Applications Exceeding Maximum Pressure and/or Temperature Indicated.

Standard Equipment: Gear-Driven Air Compressor. Hoisting Bail. Strainer. Spill Containment Base w/Integral Drains and Fork Lift Pockets. [Full Feature Control Panel](#). [Single Ball Type Float Switch](#).**

Optional Equipment: Battery. GR Hard Iron Impeller and Seal Plate. Heated Priming Chamber Kit. NPT Suction and Discharge Flange Kits. High Speed (55 MPH/89 KM/H) Single Axle Pneumatic-Tired Wheel Kit w/wo DOT-Approved Lights and Electric Brakes. [Tandem Axle Over-the-Road Trailer](#) (Meets DOT Requirements). Submersible Transducer Liquid Level Sensor.

**50 Ft. (15 m) Standard Length; Dual Switches and Alternate Cable Lengths Available From the Factory.

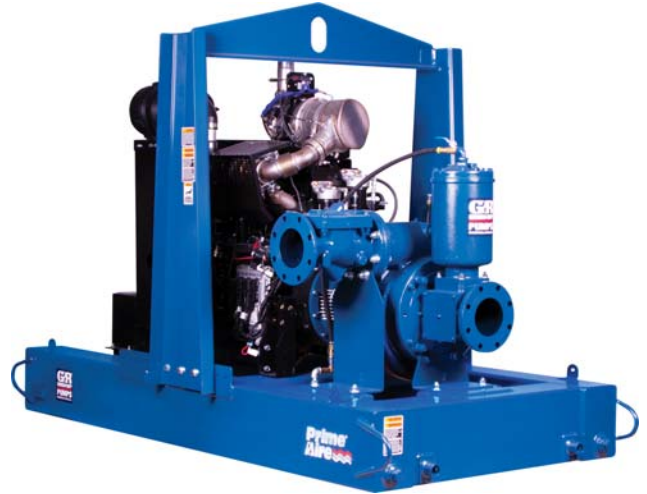

ENGINE SPECIFICATIONS

Model: John Deere 4045T.

EPA Tier: Final Tier 4.

Type: Four Cylinder, Four Cycle, Turbocharged, Liquid Cooled Diesel Engine.

Displacement: 276 Cu. In. (4,5 liters).

Lubrication: Forced Circulation.

Air Cleaner: Dry Type.

Fuel Tank: 102 U.S. Gals. (386 liters).

Full Load Operating Time: 23.5 Hrs.

Starter: 12V Electric.

Standard Features: Muffler w/Guard and Weather Cap, DOC/DPF Exhaust After-Treatment System.

Engine Control Features: Padlockable Box with Throttle Control, Tachometer, Coolant Temperature, Oil Pressure, Voltage and Overstart Indicators/Shutdowns. Manual/Stop/Auto Keyswitch. Audible Startup Warning Delay. Electronic Fuel Level Sensor. Fuel Level Display/Alarm/Shutdown

JOHN DEERE PUBLISHED PERFORMANCE:

Maximum Gross Continuous BHP
(Industrial Heavy Duty) 74 (55 kW) @ 2400 RPM



GORMAN-RUPP PUMPS

www.grpumps.com

Specifications Subject to Change Without Notice

Printed in U.S.A.

Specification Data

SECTION 42, PAGE 1139

APPROXIMATE
DIMENSIONS and WEIGHTS

NET WEIGHT:
SHIPPING WEIGHT:
EXPORT CRATE SIZE:

SKID BASE

3720 LBS. (1687,4 KG.)
3950 LBS. (1791,7 KG.)
333 CU. FT. (9,4 CU. M.)

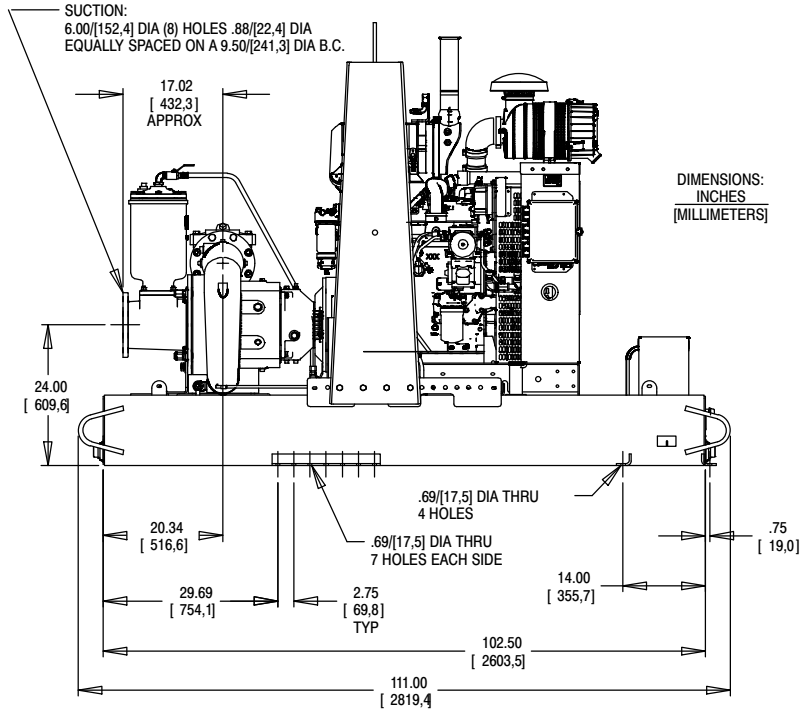
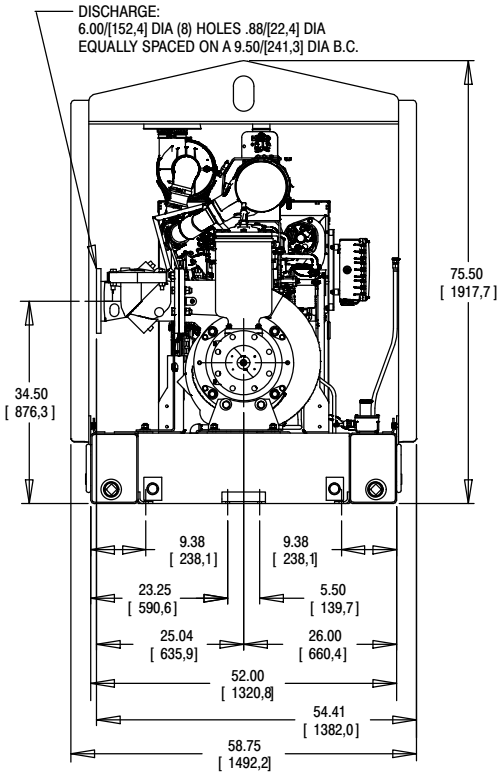

DIMENSIONS:
INCHES
(MILLIMETERS)

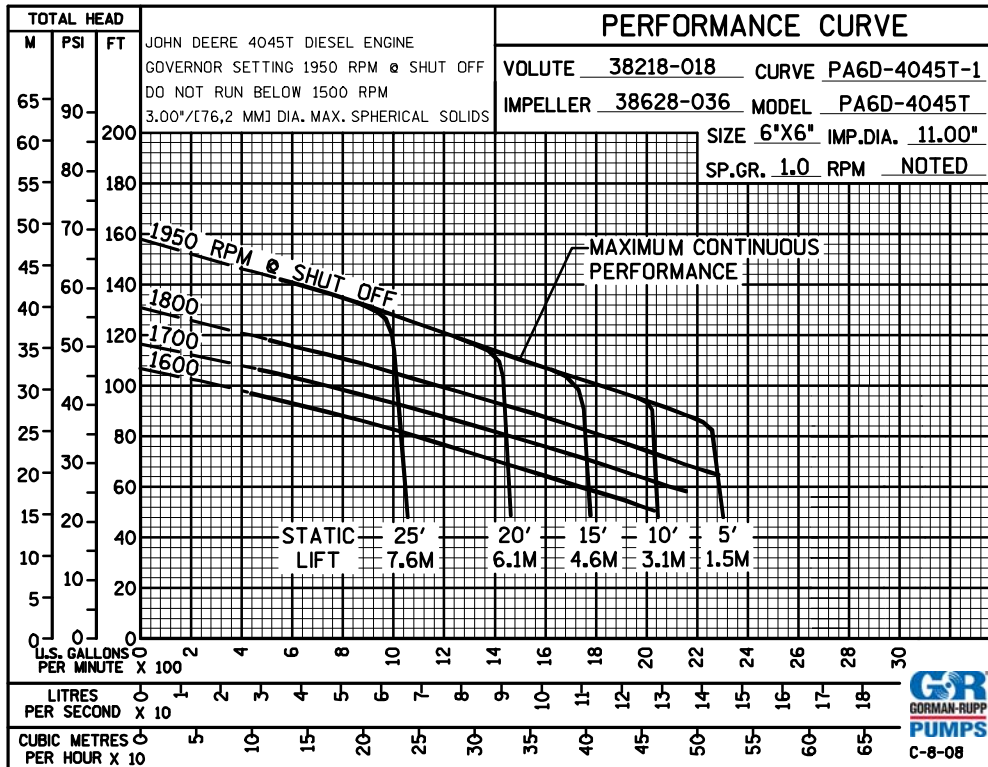

GORMAN-RUPP PUMPS

www.grpumps.com

Specifications Subject to Change Without Notice

Printed in U.S.A.