

ACDEU



Priming Assisted Centrifugal Pump w/Autostart Model PA6A60-F4L Size 6" x 6"



Total Head		Capacity of Pump in U.S. Gallons per Minute (GPM) at Continuous Performance			
P.S.I.	Feet				
60.7	140	300	300	300	300
52.0	120	700	820	820	820
43.4	100	760	1040	1200	1200
34.7	80	790	1080	1355	1510
26.0	60	820	1125	1420	1640
17.3	40	840	1180	1480	1660
Suction Lift		25'	20'	15'	10'

PUMP SPECIFICATIONS

Size: 6" x 6" NPT (152 mm x 152 mm) - Female.
Casing: Gray Iron 30.
 Maximum Operating Pressure 99 psi (683 kPa).*
Semi-Open Type, Two Vane Impeller: Ductile Iron 65-45-12. Handles 3" (76,2 mm) Diameter Spherical Solids.
Impeller Shaft: Stainless Steel 17-4 PH.
Shaft Sleeve: Stainless Steel 17-4 PH.
Replaceable Wear Plate: Steel 1015.
Intermediate Bracket: Gray Iron 30.
Seal Plate: Gray Iron 30.
Seal: Mechanical, Oil-Lubricated, Double Floating Self-Aligning. Silicon Carbide Rotating and Stationary Faces. Stainless Steel 316 Stationary Seat. Fluorocarbon Elastomers (DuPont Viton® or Equivalent). Stainless Steel 18-8 Cage and Spring. Maximum Temperature of Liquid Pumped 160°F (71°C).*
Priming Chamber: Gray Iron 30 Housing w/Stainless Steel Float and Linkage.
Discharge Check Valve: Ductile Iron w/Buna-N Flapper.
Radial Bearing: Open Single Row Ball.
Thrust Bearing: Open Double Row Ball.
Bearing and Seal Cavity Lubrication: SAE 30 Non-Detergent Oil.
Flanges: Gray Iron 30.
Gaskets: Resistant Synthetic Rubber, Cork, PTFE, Vegetable Fiber, and Compressed Synthetic Fibers.
Hardware: Standard Plated Steel.
Bearing and Seal Cavity Oil Level Sight Gauges.
**Consult Factory for Applications Exceeding Maximum Pressure and/or Temperature Indicated.*
Standard Equipment: Belt-Driven Air Compressor. Hoisting Bail. Skid Base. Strainer. Single Ball Type Float Switch.**
Optional Equipment: Battery. G-R Hard Iron Impeller. High Speed (55 MPH/89 KM/H) Single Axle Pneumatic-Tired Wheel Kit w/wo DOT-Approved Lights and Electric Brakes. Tandem Axle Over-the-Road Trailer (Meets DOT Requirements) Available w/Either Electric or Hydraulic Surge Brakes, Running Lights, Jack Stands and Safety Cables/Chains. EPS w/Submersible Transducer Liquid Level Sensor. **
****50 Ft. (15 m) Standard Length;
 150 Ft. (46 m) Maximum; Specify Length at Time of Order.**



WARNING!
 Do not use in explosive atmosphere or for pumping volatile flammable liquids.

ENGINE SPECIFICATIONS

Model: Deutz D914L4.
Type: Four Cylinder, Four Cycle, Air Cooled Diesel Engine.
Displacement: 263.2 Cu. In. (4,3 Liters).
Governor: Mechanical.
Lubrication: Forced Circulation.
Air Cleaner: Oil Bath.
Oil Reservoir: 13.7 U.S. Qts. (13 Liters) Dry; 12.7 U.S. Qts. (12 Liters) Refill.
Fuel Tank: 68.4 U.S. Gallons (259 Liters).
Full Load Operating Time: 19.2 Hrs.
Starter: 12V Electric.
Standard Features: High Oil Temperature, Low Oil Pressure, V-belt, Alternator And Start Failure Safety Shut Down Switches/Indicators. Fuel Level Gauge. Throttle Control. Autostart Instrument Panel Includes: Temperature Gauge, Oil Pressure Gauge, Ammeter, Hourmeter, Tachometer, Stop/Auto Key Switch, 15 Amp Fuse, Audible Startup Warning Delay. Muffler w/Guard and Weather Cap.

DEUTZ PUBLISHED PERFORMANCE:
 Maximum Gross Continuous B.H.P.
 73.7 (55 kW) @ 2300 RPM



THE GORMAN-RUPP COMPANY • MANSFIELD, OHIO

GORMAN-RUPP OF CANADA LIMITED • ST. THOMAS, ONTARIO, CANADA

www.grpumps.com

Specifications Subject to Change Without Notice

Printed in U.S.A.

Specification Data

SECTION 42, PAGE 700

APPROXIMATE DIMENSIONS and WEIGHTS

NET WEIGHT:	SKID BASE 2662 LBS. (1207 KG.)	2-WHEEL 3176 LBS. (1441 KG.)
SHIPPING WEIGHT:	2890 LBS. (1311 KG.)	3176 LBS. (1441 KG.)
EXPORT CRATE SIZE:	175 CU. FT. (5 CU. M.)	377 CU. FT. (10,7 CU. M.)

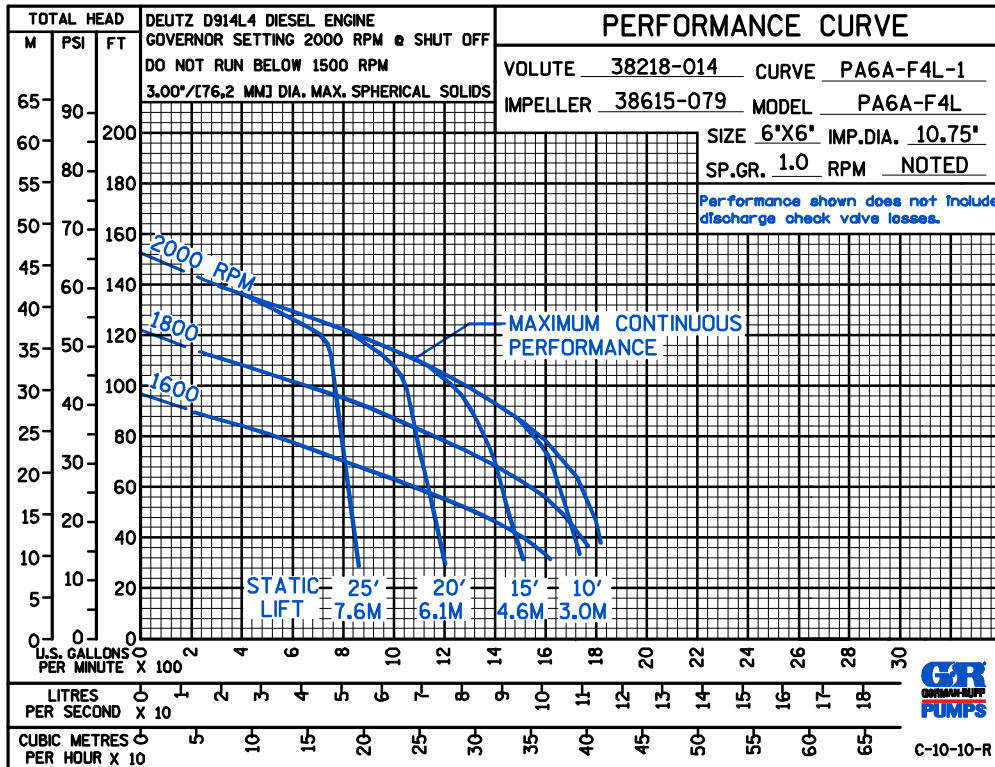
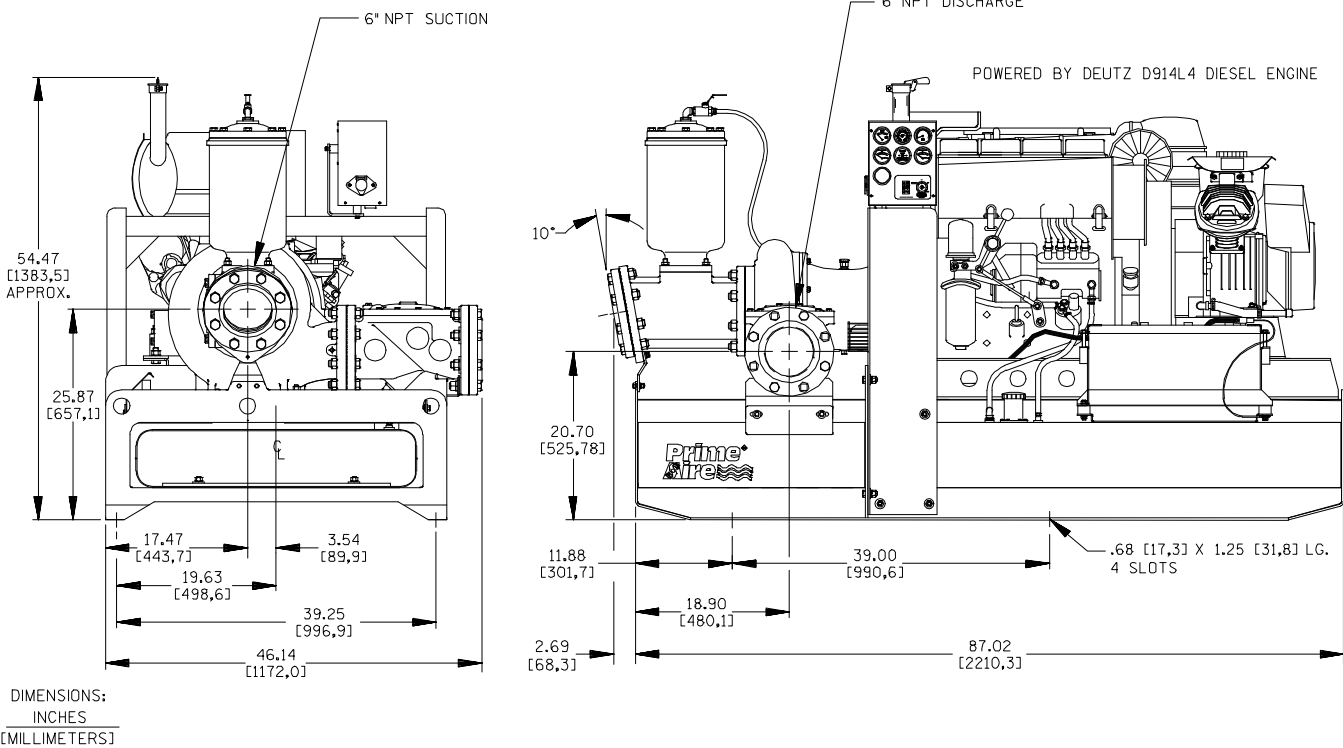

THE GORMAN-RUPP COMPANY • MANSFIELD, OHIO

GORMAN-RUPP OF CANADA LIMITED • ST. THOMAS, ONTARIO, CANADA

Specifications Subject to Change Without Notice

Printed in U.S.A.