

B-7592

B 17745

SHEET
1 OF 1

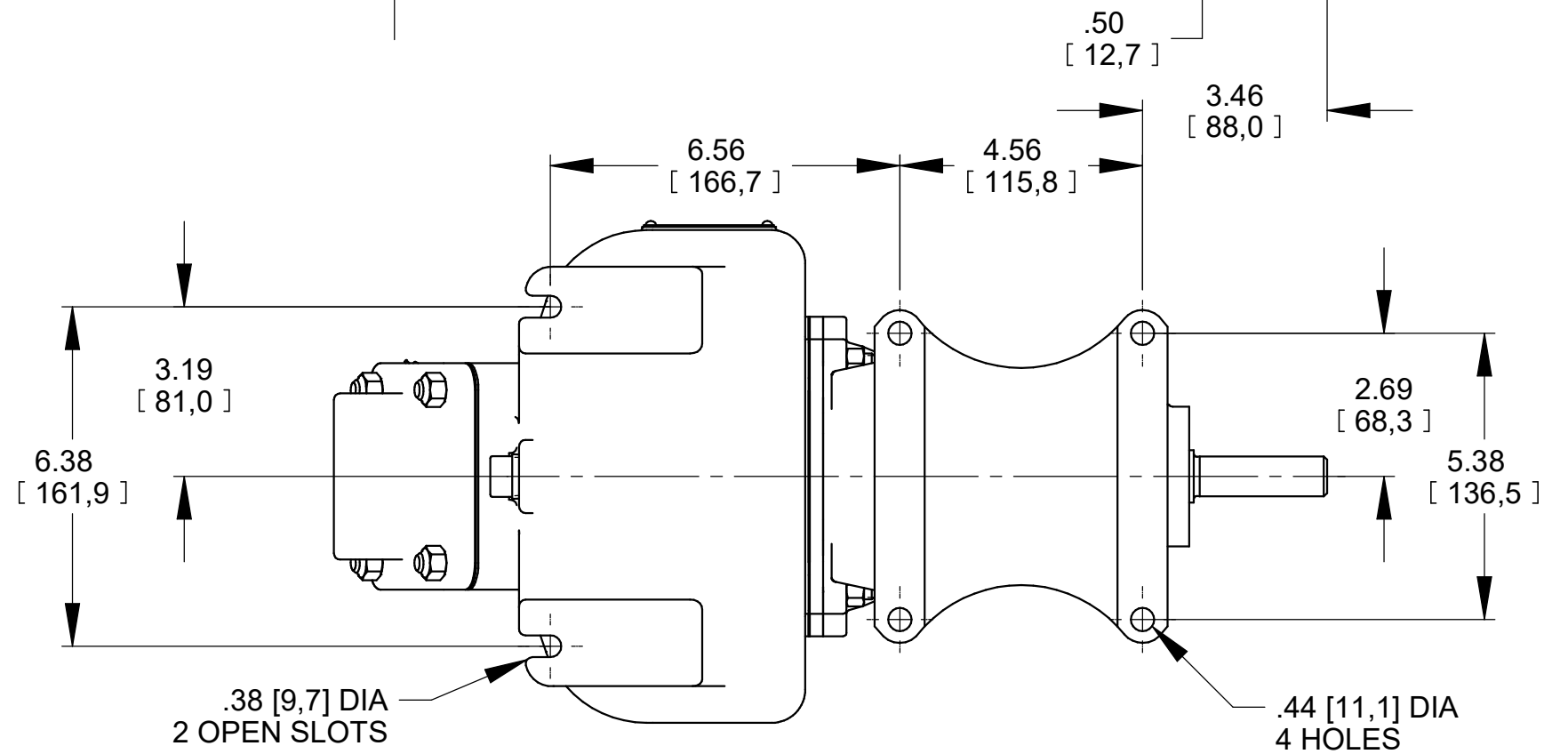
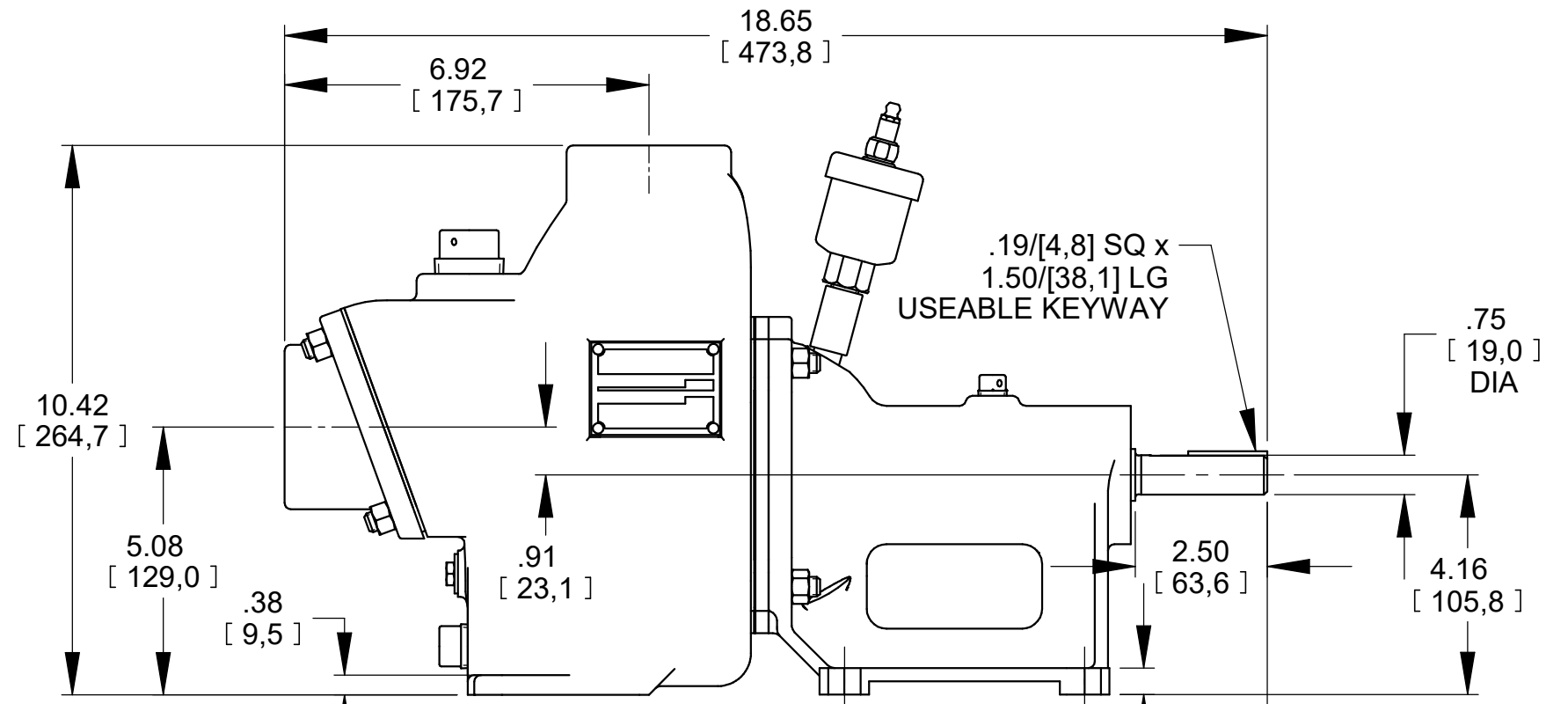
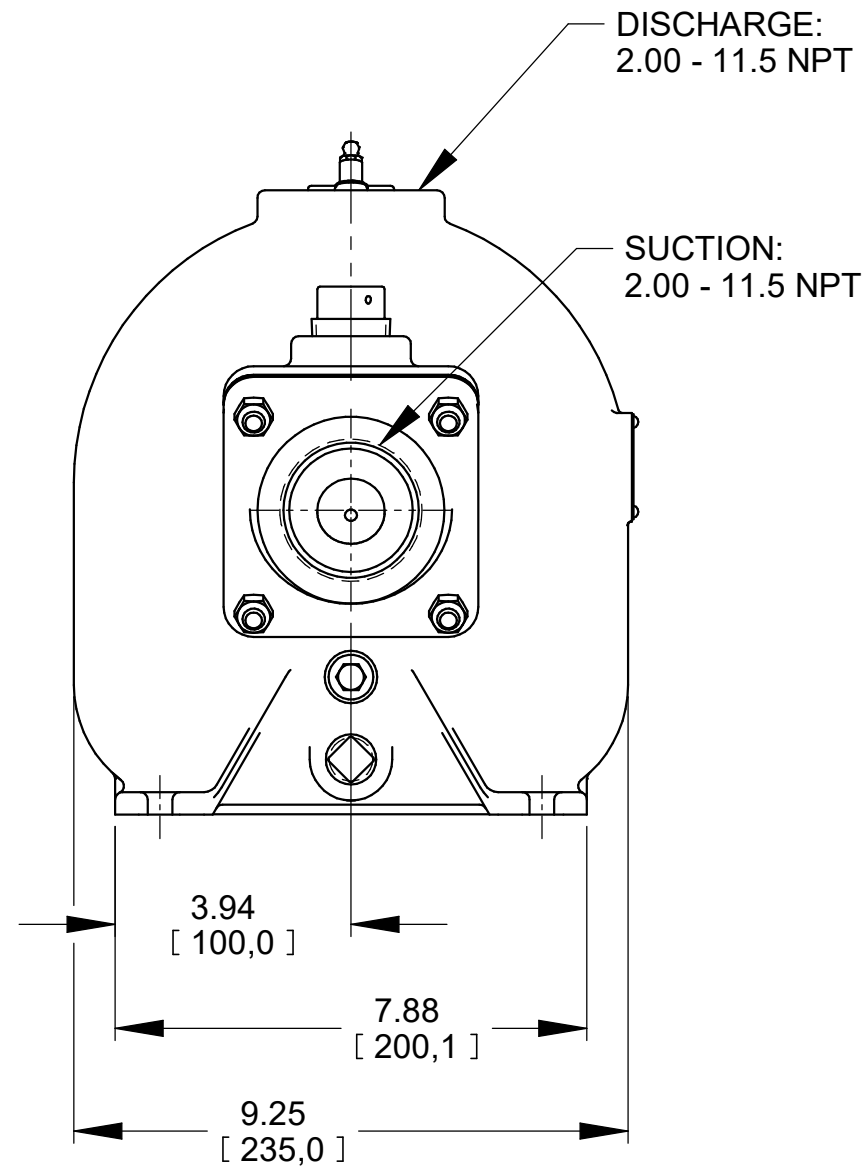

DIMENSIONS:
INCHES
[MILLIMETERS]

17-082



THE GORMAN-RUPP CO.

MANSFIELD, OHIO

ST. THOMAS, ONTARIO

DRAWN BY
CSI
DATE
3-2-05

SCALE
5/16
REVISED
6-6-18

MODEL
82D-B
OUTLINE NUMBER
17745