



# SAFETY TOOLS®

PROTECTING LIVES SINCE 1922



Catalogue



Non-sparking, non-magnetic, corrosion resistant  
Funkenfrei, amagnetisch, korrosionbeständig  
Anti-étincelles, amagnétiques, inoxydables  
Sin chispas, sin magnetismo, resistente a la corrosión



LIFETIME WARRANTY  
GARANTIE AUF LEBENSZEIT  
GARANTIE À VIE  
GARANTIA VITALICIA

EN

AMPCO Safety Tools are backed by a lifetime warranty, except for countries where a lifetime warranty is not allowed, by local law or verdicts, (e.g. Germany where the warranty is limited to 30 years). If an AMPCO tool breaks or fails to perform under normal service, it will be repaired or replaced without charge. Normal service wear or breakage, due to abuse or misuse, is not covered by the warranty.

DE

Sicherheitswerkzeuge von AMPCO haben lebenslange Garantie, ausgenommen Länder, deren Gesetze bzw. Rechtsprechung eine lebenslange Garantie nicht zulassen (z.B. Deutschland: Hier ist die Garantie auf 30 Jahre beschränkt). Sollte ein AMPCO-Werkzeug bei normaler Anwendung und Wartung funktionsuntüchtig oder beschädigt sein, werden wir das entsprechende Werkzeug kostenlos reparieren oder ersetzen. Defekte aufgrund von falscher Benutzung oder Missbrauch sowie normale Abnutzungserscheinungen sind von dieser Garantie ausgenommen.

FR

Les outils de sécurité AMPCO jouissent d'une garantie à vie, (excepté pour les pays où le concept de garantie à vie n'est pas permis par la législation (p. ex. en Allemagne où la garantie est limitée à 30 ans). Si un outil AMPCO venait à faire défaut ou à se casser dans des conditions normales d'utilisation et d'entretien, il sera réparé ou remplacé sans frais. Cette garantie ne couvre pas les défaillances imputables à un emploi incorrect ou inadapté à la tâche ou résultant d'un usage abusif. L'usure normale de service de l'outil n'est pas non plus couverte par cette garantie..

ES

Las herramientas de seguridad AMPCO están respaldadas por una garantía vitalicia, excepto los países en donde una garantía de por vida no es permitida por la ley o los veredictos locales (por ejemplo Alemania donde la garantía se limita a 30 años). De romperse o dejar de funcionar una Herramienta AMPCO en condiciones normales de uso o servicio, será reparada o reemplazada sin cargo, salvo en caso de falla por uso incorrecto, maltrato o desgaste normal en servicio.

# SUMMARY

## ZUSAMMENFASSUNG

## SOMMAIRE

## RESUMEN

# 8



Wrenches, spanners, adjustable wrenches  
Schraubenschlüssel, Verstellbare Schlüssel, Rollgabelschlüssel  
Clés de tous types, clés à molette, clés anglaises  
Llaves, llaves de cabeza ajustable, llaves inglesa

# 19



Sockets, ratchets, impact sockets,  
Steckschlüssel, Knarre, Schlagschrauber,  
Douilles, douilles à chocs  
Cubos, cubos impact

# 26



Hex keys, hook, coupling, valve-wheel, bung wrenches  
Haken, Kupplungs, Handradschlüssel, Ventilhaken  
Clés à ergot, mâle, raccord de tuyau, volant  
Llaves de gancho, hexagonal, ansas acopladas, giradora de valvulas

# 33



Pliers, tweezers, adjustable pipe wrenches, tube cutter  
Zangen, Pinzette, Verstellbare Rohrschlüssel, Rohrabschneider  
Pincas, pincettes, clés serre-tubes, coupe-tubes  
Alicates, pinzas, pinzetas, cortadora tubo

# 38



Hammers, sledge hammers, axes, hatchet  
Hämmer, Fäustel, Schlägel, Axt, Beil  
Marteaux, massettes, haches, hachettes  
Martillos, acotillos, mazos, hachas, hachuelas

# 43



Screwdrivers, screwdriver sets  
Schraubendreher, Schraubendreher-Sätze  
Tournevis, ensembles de tournevis  
Destornilladores y juegos

# 45



Punches, pins, scriber, awl  
Durchtreiber, Dome, Körner, Reissnadel, Ahle  
Broches, chasse-clou, chasse-goupilles, poinçons, goupilles, alène  
Batadores, Punzones, Pernos, Rayador, Lesna

# 48



Knives, spatulas, scrapers, mop holder  
Messer, Spachtel, Spachtelmesser, Schaber, Wischtuchhalter  
Couteaux, grattoirs, spatules, porte-faibert  
Cuchillos, Espátulas, Raspadores, Sujetador

# 53



Brushes, power brushes, brooms  
Hand-, Maschinenbürsten, Besen, Schrubber  
Brosses à main, brosses circulaires, balais  
Cepillos, Cepillos Circulares, Pinceles, Escobas

# 57



Chisels, pneumatic chisels, wedges, caulking tools, crowbars, flange spreader  
Meißel, Pressluftmeißel, Keile, Flanschlöser, Stemmwerkzeuge, Brechstangen  
Burins, burins pneumatiques, coins, décolleur, matoirs  
Cinceles, -Neumáticos, Cuñas, Herramientas de Rematar, Barras, Veleta Difusora

# 63



Utility Tools  
Dienstprogramme  
Outils utilitaires  
Utilidades herramientas

# 68



Miscellaneous  
Sonstiges  
Divers  
Diverso

# 72

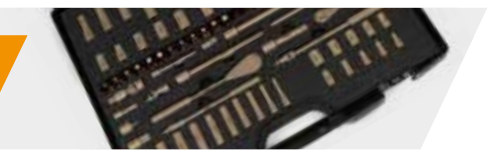

Special kits  
Spezielle Kits  
Kits spéciaux  
Kits especiales



# TOOLS AS PRECIOUS

EN

AMPCO non-sparking products are intended for use in areas where a high risk of fire or explosion exists, as in the presence of flammable gases or liquids. Non-magnetic AMPCO tools, made from a variety of AMPCO alloys with a typical magnetic permeability between 1.01 and 1.2, are recommended in military applications, mine clearance operations and in the medical field, for MRI and other scanning equipment or equipment using large magnets. Outstanding corrosion resistance also make AMPCO tools the professional's choice in the most demanding and aggressive environments, on land or water.

AMPCO SAFETY TOOLS are made from specially developed AMPCO alloys, each with ideal characteristics selected for a specific tool or product range. The superior mechanical properties of AMPCO alloys, approaching those of high-grade tool steel, the use of DIN Standards for design and rigorous control of the manufacturing process ensure the quality of all our products. AMPCO tools are supplied unpainted and without aesthetic finishes, to highlight the integrity of a tool free from porosities or other imperfections.

AMPCO Metal's confidence in its product is demonstrated by a full lifetime warranty, except countries where a lifetime warranty is not allowed by local law or verdicts, (e.g. Germany where the warranty is limited to 30 years). Any AMPCO tool will be promptly replaced should it fail under normal use, as determined by inspection at our customer service department. Tools subjected to abuse, misuse or wrong applications or fair wear and tear are, of course, not covered by the warranty.

AMPCO alloys for safety tools have been tested and approved by Factory Mutual Research Corporation under Classification 7910, for use as Non-Sparking, Non-Magnetic hand tools in hazardous environments. The use of non-sparking tools is recommended by OSHA (Occupational Safety and Health Administration), where flammable vapours or combustible products are present. AMPCO tools are approved under the MIL-specification of the US Army and Navy, and under NATO standards. They have also been tested and approved by a number of German institutions: Bundesanstalt für Materialprüfung (BAM), BG Chemie, Staatliches Materialprüfungsamt Nordrhein-Westfalen (MPA NRW) and by the Central Mining Institute in Katowice, Poland.

## PRODUCT INFORMATION

Non-sparking, non-magnetic hand tools were introduced by AMPCO Metal in 1922. Today, AMPCO Metal manufactures the widest range of safety tools available from a single manufacturer and maintains the AMPCO traditions of highest quality and craftsmanship.

DE

Funkenfreie AMPCO Produkte sind für Bereiche bestimmt, in denen eine gefährliche explosionsfähige Atmosphäre in Form von Gasen, Dämpfen, Nebel oder Stäuben vorhanden ist und dadurch das Risiko einer Explosion besteht. Antimagnetische AMPCO Werkzeuge, hergestellt aus einer Vielfalt von Legierungen mit einer magnetischen Permeabilität zwischen 1.01 und 1.2, werden zum Beispiel in der Medizintechnik, in der Kernspin-Tomographie (MRT) oder auch in der Wehrtechnik zum Minenräumen eingesetzt.

Die hervorragende Korrosionsfestigkeit und Seewasserbeständigkeit macht AMPCO Werkzeuge zur professionellen Wahl in den anspruchsvollsten und aggressivsten Umgebungen zu Lande und zu Wasser.

AMPCO Produkte werden aus eigens entwickelten AMPCO Legierungen hergestellt, die die idealen Eigenschaften bezüglich der jeweiligen Anforderungen einer bestimmten Werkzeug- oder Produktpalette besitzen. Die überlegenen mechanischen Eigenschaften von AMPCO Legierungen, die an jene von hochwertigem Werkzeugstahl grenzen, erlauben die geometrische Anlehnung an die DIN-Normen, wobei der kontrollierte Herstellungsprozess absolute Einheitlichkeit und höchste Qualität gewährleistet. AMPCO Sicherheitswerkzeuge werden unlackiert und ohne Oberflächenbeschichtung ausgeliefert, um die einwandfreie Materialqualität frei von Porositäten oder anderen Fehlstellen hervorzuheben.

Die verwendeten AMPCO Legierungen für AMPCO Sicherheitswerkzeuge wurden in der Klassifikation 7910 durch die Factory Mutual Research Corporation zur Herstellung von funkenfreien, antimagnetischen Handwerkzeugen für den Gebrauch in gefährlicher Umgebung getestet und zugelassen. Die Verwendung von Sicherheitswerkzeugen wird von der Occupational Safety and Health Administration (OSHA) bei

Vorkommen von leichtentzündlichen Dämpfen oder brennbaren Produkten empfohlen. AMPCO Sicherheitswerkzeuge sind zugelassen in den MIL-Spezifikationen der US-Armee, US-Marine und in der NATO. Sie wurden von der Bundesanstalt für Materialprüfung, Berlin (BAM), der BG Chemie, dem Staatliches Materialprüfungsamt Nordrhein-Westfalen und dem Institut für den Bergbau, Katowice, Polen, getestet und genehmigt.

Unser Vertrauen in die hohe Güte und Qualität unserer Produkte wird durch eine Garantie auf Lebenszeit unterstrichen, ausgenommen Länder, deren Gesetze bzw. Rechtsprechung eine lebenslange Garantie nicht zulassen (z.B. Deutschland: Hier ist die Garantie auf 30 Jahre beschränkt). Jedes AMPCO Werkzeug wird nach Begutachtung unseres Kundendienstes unverzüglich ersetzt, wenn es trotz sachgemäßer Verwendung zu Defekten kommen sollte. Missbrauch, unsachgemäße Handhabung oder üblicherweise auftretender Verschleiß sind von dieser Garantie ausgenommen.

#### PRODUKT INFORMATION

AMPCO Metal begann bereits 1922 mit der Produktion und dem Vertrieb von funkenfreien, antimagnetischen Handwerkzeugen. Heute produziert AMPCO METAL ein breites Spektrum an Sicherheitswerkzeugen, traditionell entsprechend den hohen Qualitäts- und Funktionalitätsansprüchen von AMPCO

# TOOLS AS PRECIOUS

FR

Les outils anti-étincelles et amagnétiques AMPCO font partie intégrante de la panoplie du professionnel exerçant son métier dans des environnements à fort risque d'explosion ou d'incendie, protégeant ainsi sa vie, celle des autres et les sites sur lesquels il intervient : par exemple raffineries, entrepôts, distribution de gaz, fabrication de poudre ou explosifs, maintenance de pipe-lines, plates-formes de forage pétrolier, silos à grain, ainsi que dans des cadres militaires comme le déminage.

Les outils de sécurité AMPCO sont aussi utilisés lors de la fabrication ou maintenance d'appareils médicaux (IRM, scanner) de par leurs propriétés amagnétiques. En effet, les alliages AMPCO utilisés sont classifiés comme non magnétiques (perméabilité magnétique de 1.01 à 1.2) et garantissent une très bonne résistance à la corrosion, utile pour des travaux dans un environnement agressif aussi bien sur mer que sur terre.

Les outils de sécurité AMPCO sont produits à partir d'alliages spécialement développés par le groupe AMPCO Metal. Chaque type d'outil est fabriqué avec l'alliage spécifique et parfaitement adapté à l'utilisation de ce dernier. Les propriétés mécaniques des alliages AMPCO utilisés, proches des aciers de qualité, alliées à des procédés de fabrication rigoureux, garantissent la qualité et fiabilité de l'outil sur l'ensemble des productions.

Les outils AMPCO sont d'ailleurs livrés sans peinture et sans finition esthétique particulière afin de souligner l'absence de défaut des matières utilisées (porosités ou autres).

En raison de leur exceptionnelle qualité, les outils de sécurité AMPCO sont garantis à vie, (excepté pour les pays où le concept de garantie à vie n'est pas permis par la législation (par exemple en Allemagne où la garantie est limitée à 30 ans).

Si un outil vient à casser ou faire défaut en conditions normales d'utilisation, il sera réparé ou remplacé gratuitement, après inspection par notre service qualité. Si la défaillance provient d'une utilisation anormale, d'un entretien insuffisant ou d'une usure normale de l'outil, cette garantie ne pourra, bien sûr, pas être d'application.

Les outils de sécurité AMPCO ont acquis une réputation indéfectible sur le marché mondial et ils sont considérés comme la référence en terme de qualité et de fiabilité à l'utilisation. Le FM (Factory Mutual Research Corporation) a validé les alliages AMPCO pour outils sous la Réf. 7910 pour leurs caractéristiques anti-étincelles et amagnétiques. L'OSHA (Occupational Safety and Health Administration) recommande également les outils de sécurité pour utilisation dans des environnements contenant des vapeurs ou des matières inflammables. Les outils de sécurité AMPCO ont obtenu la spécification «MIL» pour utilisation au sein de l'armée de terre et de mer (US Army et US Navy) et sont également classifiés par l'OTAN. Ils bénéficient également de nombreuses certifications allemandes telles que Bundesanstalt für Materialprüfung (BAM), BG Chemie, et Staatliches Materialprüfungsamt Nordrhein-Westfalen (MPA NRW), ainsi que celle de l'Institut Central des Mines de Katowice en Pologne.

## INFORMATION PRODUIT

C'est en 1922 que le groupe AMPCO Metal, producteur d'alliages spéciaux cuivreux, s'est lancé dans la fabrication des outils anti-étincelles et amagnétiques. Aujourd'hui, la Société AMPCO Metal utilise tout le savoir-faire du groupe pour fabriquer la gamme d'outils de sécurité AMPCO, utilisés et reconnus dans le monde entier.



ES

Los productos anti-chispa de AMPCO se crean para el uso en las áreas donde existe un alto riesgo de fuego o de explosión debido a la presencia de gases o de líquidos inflamables. Las herramientas anti-magnéticas de AMPCO, hechas de una variedad de aleaciones con una permeabilidad magnética típica entre 1.01 y 1.2, se recomiendan en usos militares, minería y en el campo médico, por ejemplo en el MRI, scanner y otros equipos de exploración. La excepcional resistencia a la corrosión también hace de las herramientas de AMPCO la opción de los profesionales más exigentes para los ambientes más agresivos, tanto en tierra como en agua.

Las herramientas AMPCO están fabricadas con las características especiales para cada tipo de aplicación y gama de productos. Las características mecánicas superiores de las aleaciones AMPCO, vecinas de las del acero de herramienta de alto grado, permiten el uso como guía de los estándares comunes DIN, mientras que un proceso de fabricación riguroso garantiza una uniformidad absoluta. Nuestras herramientas se suministran sin pintar y sin finales estéticos, para destacar la integridad de una herramienta libre de porosidad y de otras imperfecciones.

La confianza de AMPCO Metal en su producto está demostrada por su garantía de por vida, excepto los países, en donde una garantía de por vida no es permitida por la ley o los veredictos locales (por ejemplo Alemania donde la garantía se limita a 30 años). Cualquier herramienta de AMPCO será substituida si falla bajo uso normal, según lo determinado por la inspección en nuestro departamento de servicio de cliente. Las herramientas sujetadas al abuso, el uso erróneo o incorrecto, no están cubiertas por la garantía.

Las aleaciones AMPCO de herramienta de seguridad AMPCO han sido probadas y aprobadas por la Factory Mutual Research Corporation bajo clasificación 7910, para el uso como herramientas anti-chispa y antimagnéticas en ambientes peligrosos. El uso de herramientas anti-chispa es recomendado por la Occupational Safety and Health Administration (OSHA) allí donde haya presencia de vapores inflamables o productos combustibles. Las herramientas de seguridad de AMPCO son aprobadas bajo especificación MIL del ejército y de la marina de los E.E.U.U., y bajo estándares de la OTAN; también han sido probadas y aprobadas por organizaciones alemanas: el Bundesanstalt für Materialprüfung (BAM), BG Chemie y el Staatliches Materialprüfungsamt Nordrhein-Westfalen (MPA NRW), así que por el Instituto Central Minero, Katowice en Polonia.

### INFORMACIÓN DE PRODUCTO

Las herramientas manuales anti-chispas y anti-magnéticas fueron introducidas por el Grupo AMPCO Metal en 1922. Hoy, AMPCO METAL fabrica un espectro completo de herramientas de seguridad fieles a los ideales siempre constantes de AMPCO, la calidad más alta y la mejor artesanía.

AA > AU

WRENCHES  
SCHLÜSSEL  
CLÉS  
LLAVES





AA  
BA

**Combination wrench**

Ringmaulschlüssel  
Clé mixte  
Llave combinada

DIN 3113



Part No.	s mm	l mm	g
AA0006	6	120	30
AA0007	7	120	30
AA0008	8	150	50
AA0009	9	150	50
AA0010	10	175	75
AA0011	11	175	75
AA0012	12	205	115
AA0013	13	205	115
AA0014	14	205	115
AA0015	15	225	145
AA0016	16	225	145
AA0017	17	270	260
AA0018	18	270	260
AA0019	19	270	260
AA0020	20	295	300
AA0021	21	295	300
AA0022	22	295	300
AA0023	23	325	400
AA0024	24	325	400
AA0025	25	355	550
AA0026	26	355	550
AA0027	27	355	550
AA0028	28	390	690
AA0029	29	390	690
AA0030	30	390	690
AA0032	32	430	1000
AA0034	34	430	1000
AA0036	36	475	1100
AA0038	38	475	1100
AA0041	41	525	1450
AA0046	46	550	1900
AA0050	50	575	2200
AA0055	55	575	2600
AA0060	60	575	3150
AA0065	65	575	4580
AA0070	70	575	4580
AA0075	75	640	5450
AA0080	80	640	5450

Part No.	s inch	l mm	g
BA0008	5/16	150	50
BA0009	3/8	150	50
BA0010	13/32	175	75
BA0011	7/16	175	75
BA0013	1/2	205	115
BA0014	9/16	205	115
BA0015	19/32	225	145
BA0016	5/8	225	145
BA0018	11/16	270	260
BA0019	3/4	270	260
BA0020	25/32	295	300
BA0021	13/16	295	300
BA0022	7/8	295	300
BA0024	15/16	325	400
BA0025	31/32	325	400
BA0026	1	355	550
BA0027	1.1/16	355	550
BA0029	1.1/8	390	690
BA0030	1.3/16	390	690
BA0032	1.1/4	430	1000
BA0033	1.5/16	430	1000
BA0035	1.3/8	475	1100
BA0037	1.7/16	475	1100
BA0038	1.1/2	475	1100
BA0039	1.9/16	525	1450
BA0041	1.5/8	525	1450
BA0043	1.11/16	575	1900
BA0044	1.3/4	550	1900
BA0051	2	575	2200
BA0056	2.3/16	575	2600
BA0060	2.3/8	575	3150
BA0065	2.9/16	575	4580
BA0067	2.5/8	575	4580
BA0070	2.3/4	575	4580

AA

**Combination wrench, sets**

Ringmaulschlüssel-Sätze  
Clé mixte, jeux  
Llave combinada, juego

Part No.	Parts	s mm	g
AA9009	9	6,7,8,10,13,15,17,18,19	1225
AA9011	11	10,13,15,17,18,19,21 22,24,27,30	3355
AA9014	14	10,11,12,13,14,15,16 17,18,19,20,21,22,24	2865

Part No.	Parts	s inch	g
BA9007	7	3/8,7/16,1/2,9/16 5/8,3/4,7/8	1200

AB  
BB**Double open end wrench**Doppelmaulschlüssel  
Clé à fourche double  
Llave de boca doble

DIN 895



Part No.	s1 x s2 mm	l mm	g
AB0607	6x7	95	25
AB0608	6x8	100	30
AB0708	7x8	100	30
AB0709	7x9	110	35
AB0809	8x9	110	35
AB0810	8x10	115	40
AB0910	9x10	115	40
AB0911	9x11	125	50
AB1011	10x11	125	50
AB1012	10x12	125	65
AB1013	10x13	125	65
AB1113	11x13	145	85
AB1114	11x14	145	85
AB1213	12x13	145	85
AB1214	12x14	145	85
AB1314	13x14	145	105
AB1315	13x15	155	105
AB1415	14x15	155	105
AB1416	14x16	155	105
AB1417	14x17	170	130
AB1617	16x17	170	130
AB1618	16x18	170	130
AB1719	17x19	185	165
AB1819	18x19	185	165
AB1820	18x20	185	165
AB1722	17x22	200	240
AB1922	19x22	200	240
AB2022	20x22	200	240
AB1924	19x24	220	300
AB2123	21x23	220	300
AB2223	22x23	220	300
AB2224	22x24	220	300
AB2227	22x27	240	390
AB2326	23x26	240	390
AB2426	24x26	240	390
AB2427	24x27	240	390
AB2528	25x28	260	485
AB2430	24x30	260	485
AB2730	27x30	260	485
AB2732	27x32	285	650
AB3032	30x32	285	650
AB3034	30x34	310	850
AB3036	30x36	310	850
AB3236	32x36	310	850
AB3436	34x36	310	850
AB3641	36x41	340	1150
AB4146	41x46	375	1500
AB4650	46x50	415	1900
AB5055	50x55	455	2500
AB5060	50x60	505	3200
AB5560	55x60	505	3200
AB6570	65x70	555	4600

Part No.	s1 x s2 inch	l mm	g
BB0608	1/4x5/16	100	30
BB0809	5/16x3/8	115	40
BB0911	3/8x7/16	125	50
BB1113	7/16x1/2	135	65
BB1316	1/2x5/8	155	105
BB1314	1/2x9/16	155	105
BB1416	9/16x5/8	170	130
BB1419	9/16x3/4	185	165
BB1518	19/32x11/16	185	165
BB1520	19/32x25/32	185	165
BB1618	5/8x11/16	185	165
BB1619	5/8x3/4	185	165
BB1820	11/16x25/32	185	165
BB1822	11/16x7/8	200	240
BB1920	3/4x25/32	200	240
BB1921	3/4x13/16	200	240
BB1922	3/4x7/8	200	240
BB2022	25/32x7/8	200	240
BB2122	13/16x7/8	200	240
BB2224	7/8x15/16	220	300
BB2225	7/8x31/32	220	300
BB2226	7/8x1	240	390
BB2227	7/8x1.1/16	240	390
BB2426	15/16x1	240	390
BB2427	15/16x1.1/16	240	390
BB2629	1x1.1/8	260	485
BB2633	1x1.5/16	285	650
BB2732	1.1/16x1.1/4	285	650
BB2933	1.1/8x1.5/16	285	650
BB2737	1.1/16x1.7/16	310	850
BB2938	1.1/8x1.1/2	310	850
BB3235	1.1/4x1.3/8	310	850
BB3237	1.1/4x1.7/16	310	850
BB3338	1.5/16x1.1/2	310	850
BB3241	1.1/4x1.5/8	340	1150
BB3538	1.3/8x1.1/2	340	1150
BB3741	1.7/16x1.5/8	340	1150
BB3843	1.1/2x1.11/16	340	1150
BB4146	1.5/8x1.13/16	375	1500
BB4144	1.5/8x1.3/4	375	1900
BB4348	1.11/16x1.7/8	375	1900
BB4651	1.13/16x2	415	1900
BB4452	1.3/4x2.1/16	415	2500
BB5156	2x2.3/16	455	2500
BB5660	2.3/16x2.3/8	505	3200

AB

**Double open end wrench, sets**Doppelmaulschlüssel-Sätze  
Clé à fourche double, jeu  
Llave de boca doble, juego

Part No.	Parts	s1 x s2 mm	g
AB9008	8	6x7,8x9,10x11,12x13,14x15 16x17,18x20,19x22	835
AB9012	12	6x7,8x9,10x11,12x13,14x15 16x17,18x19,20x22,21x23,24x26 27x32,30x34	2865

AC  
BC

**Double end box wrench offset**

Doppelringschlüssel gekröpft  
Clé polygonale double contre-coudée  
Llave de cajón doble tipo acodado

DIN 897



Part No.	s1 x s2 mm	l mm	g
AC0607	6x7	155	40
AC0709	7x9	155	40
AC0809	8x9	155	40
AC0810	8x10	170	77
AC0911	9x11	170	77
AC1011	10x11	170	77
AC1012	10x12	180	105
AC1013	10x13	180	105
AC1112	11x12	180	105
AC1213	12x13	180	105
AC1014	10x14	200	130
AC1114	11x14	200	130
AC1214	12x14	200	130
AC1315	13x15	220	180
AC1415	14x15	220	180
AC1417	14x17	230	200
AC1617	16x17	260	255
AC1618	16x18	260	255
AC1719	17x19	280	300
AC1819	18x19	280	300
AC1722	17x22	330	420
AC1922	19x22	330	420
AC1924	19x24	360	560
AC2022	20x22	330	420
AC2123	21x23	360	560
AC2224	22x24	360	560
AC2426	24x26	400	660
AC2427	24x27	400	660
AC2528	25x28	400	660
AC2430	24x30	410	820
AC2730	27x30	410	820
AC2732	27x32	410	820
AC3032	30x32	430	960
AC3034	30x34	480	1350
AC3036	30x36	480	1350
AC3236	32x36	480	1350
AC3436	34x36	480	1350
AC3641	36x41	510	1750
AC4146	41x46	580	2550
AC4650	46x50	630	3300
AC5055	50x55	690	4250
AC5060	50x60	740	5300
AC5560	55x60	740	5300
AC6570	65x70	800	7600
AC7075	70x75	830	9400

Part No.	s1 x s2 inch	l mm	g
BC0608	1/4x5/16	155	40
BC0809	5/16x3/8	155	40
BC0911	3/8x7/16	170	77
BC1113	7/16x1/2	180	105
BC1314	1/2x9/16	220	130
BC1315	1/2x19/32	220	130
BC1416	9/16x5/8	220	180
BC1619	5/8x3/4	260	255
BC1820	11/16x25/32	280	300
BC1922	3/4x7/8	330	420
BC2122	13/16x7/8	330	420
BC2426	15/16x1	400	660
BC2427	15/16x1 1/16	400	660
BC2629	1x1.1/8	410	820
BC2729	1.1/16x1.1/8	410	820
BC2732	1.1/16x1.1/4	410	820
BC2933	1.1/8x1.5/16	430	960
BC2938	1.1/8x1.1/2	480	1350
BC3237	1.1/4x1.7/16	480	1350
BC3741	1.7/16x1.5/8	510	1750
BC4146	1.5/8x1.13/16	580	2550
BC4651	1.13/16x2	630	3300
BC5156	2x2.3/16	690	4250
BC5160	2x2.3/8	740	5300
BC5660	2.3/16x2.3/8	740	5300
BC6570	2.9/16x2.3/4	800	7600
BC7075	2.3/4x2.15/16	830	9400

AC

**Double end box wrench offset, sets**

Doppelringschlüssel-Sätze, gekröpft  
Clé polygonale double droite contre-coudée, jeux  
Llave de Cajón Doble tipo acodado, juego

Part No.	Parts	s1 x s2 mm	g
AC9008	8	6x7,8x9,10x11,12x13,14x15 16x17,18x20,19x22	1420
AC9012	12	6x7,8x9,10x11,12x13,14x15 16x17,18x19,20x22,21x23,24x26 27x32,30x34	4810



AD  
BD**Double end box wrench flat**Doppelringschlüssel gerade  
Clé polygonale double droite  
Llave de cajón doble tipo recto

DIN 837



Part No.	s1 x s2 mm	l mm	g
AD0607	6x7	100	15
AD0810	8x10	125	30
AD0911	9x11	133	45
AD1214	12x14	155	60
AD1315	13x15	170	90
AD1417	14x17	170	90
AD1618	16x18	190	125
AD1719	17x19	190	125
AD1922	19x22	215	195
AD2123	21x23	235	215
AD2427	24x27	270	280
AD2628	26x28	295	370
AD3032	30x32	330	450
AD3036	30x36	360	715
AD3236	32x36	360	715
AD3641	36x41	400	800

Part No.	s1 x s2 inch	l mm	g
BD0608	1/4x5/16	100	15
BD0809	5/16x3/8	125	30
BD0910	3/8x7/16	133	45
BD1114	7/16x9/16	155	60
BD1315	1/2x19/32	170	90
BD1316	1/2x5/8	170	90
BD1418	9/16x11/16	170	125
BD1620	5/8x25/32	190	125
BD1821	11/16x13/16	215	195
BD1922	3/4x7/8	215	195
BD2124	13/16x15/16	235	215
BD2427	15/16x1.1/16	270	280
BD2629	1x1.1/8	295	370
BD2933	1.1/8x1.5/16	330	450
BD3032	1.3/16x1.1/4	330	450
BD3235	1.1/4x1.3/8	360	715
BD3337	1.5/16x1.7/16	360	715
BD3840	1.1/2x1.5/8	400	800

AE  
BE**Single open end wrench**Einfachmaulschlüssel  
Clé à fourche simple  
Llave de boca sencilla

DIN 894



Part No.	s mm	l mm	g
AE0008	8	100	28
AE0009	9	110	30
AE0010	10	115	35
AE0011	11	125	45
AE0012	12	135	55
AE0013	13	145	70
AE0014	14	145	70
AE0015	15	155	90
AE0016	16	155	90
AE0017	17	170	115
AE0018	18	170	115
AE0019	19	185	155
AE0020	20	185	155
AE0021	21	200	180
AE0022	22	200	180
AE0023	23	220	250
AE0024	24	220	250
AE0025	25	240	350
AE0026	26	240	350
AE0027	27	240	350
AE0028	28	260	420
AE0029	29	260	420
AE0030	30	260	420
AE0032	32	285	550
AE0033	33	285	550
AE0034	34	285	550
AE0035	35	310	710
AE0036	36	310	710
AE0037	37	310	710
AE0038	38	310	710
AE0041	41	340	980
AE0042	42	340	980
AE0046	46	375	1160
AE0047	47	375	1160
AE0050	50	415	1660
AE0052	52	415	1660
AE0054	54	455	2210
AE0055	55	455	2210
AE0056	56	455	2210
AE0058	58	505	2940
AE0060	60	505	2940
AE0063	63	505	2940
AE0065	65	555	4000
AE0067	67	555	4000
AE0070	70	555	4000
AE0071	71	555	4000
AE0075	75	615	4800
AE0077	77	615	4800
AE0080	80	615	4800
AE0082	82	690	6250
AE0085	85	690	6250
AE0088	88	690	6250
AE0090	90	690	6250
AE0094	94	770	8300
AE0095	95	770	8300
AE0100	100	770	8300

Part No.	s inch	l mm	g
BE0008	5/16	100	28
BE0009	3/8	115	35
BE0010	13/32	115	35
BE0011	7/16	125	45
BE0013	1/2	145	70
BE0014	9/16	145	70
BE0015	19/32	155	90
BE0016	5/8	155	90
BE0018	11/16	170	115
BE0019	3/4	185	155
BE0020	25/32	185	155
BE0021	13/16	200	180
BE0022	7/8	200	180
BE0024	15/16	220	250
BE0025	31/32	220	250
BE0026	1	240	350
BE0027	1.1/16	240	350
BE0029	1.1/8	260	420
BE0030	1.3/16	260	420
BE0032	1.1/4	285	550
BE0033	1.5/16	285	550
BE0035	1.3/8	310	710
BE0037	1.7/16	310	710
BE0038	1.1/2	310	710
BE0039	1.9/16	340	980
BE0041	1.5/8	340	980
BE0043	1.11/16	375	1160
BE0044	1.3/4	375	1160
BE0046	1.13/16	375	1160
BE0048	1.7/8	415	1660
BE0051	2	415	1660
BE0052	2.1/16	455	2210
BE0054	2.1/8	455	2210
BE0056	2.3/16	455	2210
BE0057	2.1/4	455	2210
BE0059	2.5/16	505	2940
BE0060	2.3/8	505	2940
BE0062	2.7/16	505	2940
BE0064	2.1/2	555	4000
BE0065	2.9/16	555	4000
BE0067	2.5/8	555	4000
BE0070	2.3/4	555	4000
BE0071	2.13/16	555	4000
BE0075	2.15/16	615	4800
BE0076	3	615	4800
BE0079	3.1/8	615	4800
BE0083	3.1/4	690	6250
BE0086	3.3/8	690	6250
BE0089	3.1/2	690	6250
BE0092	3.5/8	770	8300
BE0095	3.3/4	770	8300
BE0098	3.7/8	770	8300

AF  
BF

**Single end box wrench**

Einfachringschlüssel  
Clé fermée  
Llave de Cajón sencilla

DIN 3111



Part No.	s mm	l mm	g
AF0013	13	138	65
AF0014	14	138	65
AF0015	15	138	65
AF0016	16	155	90
AF0017	17	155	90
AF0018	18	171	125
AF0019	19	171	125
AF0020	20	171	125
AF0021	21	190	160
AF0022	22	190	160
AF0023	23	190	160
AF0024	24	215	250
AF0025	25	215	250
AF0026	26	215	250
AF0027	27	230	280
AF0028	28	230	280
AF0029	29	230	280
AF0030	30	254	370
AF0032	32	265	400
AF0033	33	265	400
AF0034	34	295	610
AF0035	35	295	610
AF0036	36	295	610
AF0037	37	295	610
AF0038	38	295	610
AF0041	41	330	750
AF0042	42	330	750
AF0046	46	365	1050
AF0047	47	365	1050
AF0050	50	400	1400
AF0052	52	400	1400
AF0054	54	400	1400
AF0055	55	442	1700
AF0056	56	442	1700
AF0058	58	442	1700
AF0060	60	475	1900
AF0063	63	475	1900
AF0065	65	510	2300
AF0067	67	510	2300
AF0070	70	555	2900
AF0071	71	555	2900
AF0075	75	590	3050
AF0077	77	590	3050
AF0080	80	620	4700
AF0082	82	620	4700
AF0085	85	665	4900

Part No.	s mm	l mm	g
AF0088	88	665	4900
AF0090	90	700	5800
AF0094	94	700	5800
AF0095	95	700	5800

Part No.	s inch	l mm	g
BF0013	1/2	138	65
BF0014	9/16	138	65
BF0015	19/32	138	65
BF0016	5/8	155	90
BF0018	11/16	155	90
BF0019	3/4	171	125
BF0020	25/32	171	125
BF0021	13/16	171	125
BF0022	7/8	190	160
BF0024	15/16	215	250
BF0025	31/32	215	250
BF0026	1	215	250
BF0027	1.1/16	230	280
BF0029	1.1/8	230	280
BF0030	1.3/16	254	370
BF0032	1.1/4	265	400
BF0033	1.5/16	265	400
BF0035	1.3/8	295	610
BF0037	1.7/16	295	610
BF0038	1.1/2	295	610
BF0039	1.9/16	330	750
BF0041	1.5/8	330	750
BF0043	1.11/16	330	750
BF0044	1.3/4	365	1050
BF0046	1.13/16	365	1050
BF0048	1.7/8	365	1050
BF0051	2	400	1400
BF0052	2.1/16	400	1400
BF0054	2.1/8	442	1700
BF0056	2.3/16	442	1700
BF0057	2.1/4	442	1700
BF0059	2.5/16	475	1900
BF0060	2.3/8	475	1900
BF0062	2.7/16	475	1900
BF0064	2.1/2	510	2300
BF0065	2.9/16	510	2300
BF0070	2.3/4	555	2900
BF0075	2.15/16	590	3050
BF0076	3	590	3050
BF0079	3.1/8	620	4700
BF0086	3.3/8	665	4900
BF0089	3.1/2	700	5800
BF0095	3.3/4	700	5800

AH  
BH**Striking box wrench 12 point**Ringschlagschlüssel, 12-Kant  
Clé à frapper polygonale, 12 pans  
Llave de Cajón de Golpe, 12-puntos

DIN 7444



Part No.	s mm	l mm	g
AH0017	17	145	210
AH0019	19	145	210
AH0022	22	170	305
AH0024	24	170	305
AH0025	25	170	305
AH0026	26	180	350
AH0027	27	180	350
AH0028	28	180	350
AH0029	29	180	465
AH0030	30	190	465
AH0032	32	190	465
AH0033	33	190	465
AH0034	34	190	465
AH0035	35	205	575
AH0036	36	205	575
AH0037	37	205	575
AH0038	38	205	575
AH0041	41	230	760
AH0042	42	230	760
AH0046	46	242	1030
AH0047	47	242	1030
AH0050	50	254	1240
AH0052	52	254	1240
AH0054	54	254	1490
AH0055	55	268	1490
AH0056	56	268	1490
AH0058	58	268	1780
AH0060	60	283	1780
AH0063	63	283	1780
AH0065	65	300	2200
AH0067	67	300	2200
AH0070	70	325	3140
AH0071	71	325	3140
AH0075	75	325	3140
AH0077	77	325	3140
AH0080	80	358	4025
AH0082	82	358	4025
AH0085	85	358	4025
AH0088	88	388	5400
AH0090	90	388	5400
AH0094	94	388	5400
AH0095	95	388	5400
AH0100	100	415	7490
AH0105	105	415	7490
AH0110	110	450	8500
AH0115	115	450	8500
AH0120	120	475	12750
AH0125	125	475	12750
AH0130	130	505	17250
AH0135	135	505	17250
AH0145	145	575	21000
AH0150	150	575	21000
AH0155	155	575	21000



Part No.	s inch	l mm	g
BH0019	3/4	145	210
BH0022	7/8	170	305
BH0024	15/16	170	305
BH0026	1	170	305
BH0027	1.1/16	180	350
BH0029	1.1/8	180	350
BH0030	1.3/16	190	465
BH0032	1.1/4	190	465
BH0033	1.5/16	190	465
BH0035	1.3/8	205	575
BH0037	1.7/16	205	575
BH0038	1.1/2	205	575
BH0039	1.9/16	230	760
BH0041	1.5/8	230	760
BH0043	1.11/16	230	760
BH0044	1.3/4	242	1030
BH0046	1.13/16	242	1030
BH0048	1.7/8	242	1030
BH0051	2	254	1240
BH0052	2.1/16	254	1240
BH0054	2.1/8	268	1490
BH0056	2.3/16	268	1490
BH0057	2.1/4	268	1490
BH0059	2.5/16	283	1760
BH0060	2.3/8	283	1760
BH0062	2.7/16	283	1760
BH0064	2.1/2	283	1760
BH0065	2.9/16	300	2200
BH0067	2.5/8	300	2200
BH0070	2.3/4	325	3140
BH0071	2.13/16	325	3140
BH0075	2.15/16	325	3140
BH0076	3	325	3140
BH0079	3.1/8	358	4025
BH0083	3.1/4	358	4025
BH0086	3.3/8	358	4025
BH0089	3.1/2	388	5400
BH0092	3.5/8	388	5400
BH0095	3.3/4	388	5400
BH0098	3.7/8	415	7490
BH0102	4	415	7490
BH0105	4.1/8	415	7490
BH0110	4.5/16	450	8500
BH0116	4.9/16	450	8500
BH0119	4.11/16	475	12570
BH0125	4.15/16	475	12570
BH0130	5.1/8	505	17250
BH0137	5.3/8	505	17250
BH0145	5.11/16	575	21000
BH0152	6	575	21000

**AJ  
BJ**

**Striking open end wrench**

Maulschlagschlüssel  
Clé à frapper à fourche  
Llave de boca de golpe

DIN 133



Part No.	s mm	l mm	g
AJ0027	27	180	380
AJ0028	28	180	380
AJ0029	29	180	380
AJ0030	30	190	440
AJ0032	32	190	440
AJ0033	33	190	440
AJ0034	34	190	440
AJ0035	35	215	750
AJ0036	36	215	750
AJ0037	37	215	750
AJ0038	38	215	750
AJ0041	41	235	1150
AJ0042	42	235	1150
AJ0046	46	255	1400
AJ0047	47	255	1400
AJ0050	50	275	1600
AJ0052	52	275	1600
AJ0054	54	300	1800
AJ0055	55	300	1800
AJ0056	56	300	1800
AJ0058	58	320	2500
AJ0060	60	320	2500
AJ0063	63	320	2500
AJ0065	65	340	3700
AJ0067	67	340	3700
AJ0070	70	375	4000
AJ0075	75	375	4000
AJ0080	80	410	6300
AJ0085	85	410	6300
AJ0090	90	445	8000
AJ0095	95	445	8000
AJ0100	100	485	9900
AJ0105	105	485	9900
AJ0110	110	510	19500
AJ0115	115	510	19500
AJ0120	120	545	23000
AJ0125	125	545	23000
AJ0130	130	575	28000
AJ0135	135	575	28000
AJ0145	145	640	38000
AJ0150	150	640	38000
AJ0155	155	640	38000

Part No.	s inch	l mm	g
BJ0027	1.1/16	180	380
BJ0029	1.1/8	180	380
BJ0030	1.3/16	190	440
BJ0032	1.1/4	190	440
BJ0033	1.5/16	190	440
BJ0035	1.3/8	215	750
BJ0037	1.7/16	215	750
BJ0038	1.1/2	215	750
BJ0039	1.9/16	235	1150
BJ0041	1.5/8	235	1150

Part No.	s inch	l mm	g
BJ0043	1.11/16	235	1150
BJ0044	1.3/4	255	1400
BJ0046	1.13/16	255	1400
BJ0048	1.7/8	255	1400
BJ0051	2	275	1600
BJ0052	2.1/16	275	1600
BJ0054	2.1/8	300	1800
BJ0056	2.3/16	300	1800
BJ0057	2.1/4	300	1800
BJ0059	2.5/16	320	2500
BJ0060	2.3/8	320	2500
BJ0062	2.7/16	320	2500
BJ0064	2.1/2	340	3700
BJ0065	2.9/16	340	3700
BJ0067	2.5/8	340	3700
BJ0070	2.3/4	375	4000
BJ0071	2.13/16	375	4000
BJ0075	2.15/16	375	4000
BJ0076	3	375	4000
BJ0079	3.1/8	410	6300
BJ0083	3.1/4	410	6300
BJ0086	3.3/8	410	6300
BJ0089	3.1/2	445	8000
BJ0092	3.5/8	445	8000
BJ0095	3.3/4	445	8000
BJ0098	3.7/8	485	9900
BJ0102	4	485	9900
BJ0105	4.1/8	485	9900
BJ0110	4.5/16	510	19500
BJ0116	4.9/16	510	19500
BJ0119	4.11/16	545	23000
BJ0125	4.15/16	545	23000
BJ0137	5.3/8	575	28000
BJ0152	6	640	38000

AK  
BK**Single end box wrench for extension tube**

Ringzugschlüssel  
Clé polygonale à traction  
Llave de cajón para extensión



Part No.	s mm	l mm	g	Tube
AK0030	30	235	800	
AK0032	32	235	800	
AK0033	33	235	800	
AK0034	34	235	800	
AK0035	35	245	850	AK1600
AK0036	36	245	850	
AK0037	37	245	850	
AK0038	38	255	950	
AK0041	41	265	1000	
AK0042	42	265	1000	
AK0046	46	280	1400	AK1700

Part No.	s mm	l mm	g	Tube
AK0047	47	280	1400	
AK0050	50	290	1550	
AK0052	52	290	1550	AK1700
AK0054	54	300	1650	
AK0055	55	300	1650	
AK0056	56	300	1650	
AK0058	58	345	2450	
AK0060	60	345	2450	
AK0063	63	345	2450	
AK0065	65	355	2700	
AK0067	67	355	2700	
AK0070	70	365	2850	AK1750
AK0071	71	365	2850	
AK0075	75	375	3200	
AK0077	77	375	3200	
AK0080	80	385	3600	
AK0082	82	385	3600	
AK0085	85	385	3600	

Part No.	s inch	l mm	g	Tube
BK0030	1.3/16	235	800	
BK0032	1.1/4	235	800	
BK0033	1.5/16	235	800	
BK0035	1.3/8	245	850	
BK0037	1.7/16	245	850	AK1600
BK0038	1.1/2	255	950	
BK0039	1.9/16	255	1000	
BK0041	1.5/8	265	1000	
BK0043	1.11/16	265	1000	
BK0044	1.3/4	280	1400	
BK0046	1.13/16	280	1400	
BK0048	1.7/8	290	1550	
BK0051	2	290	1550	
BK0052	2.1/16	290	1550	AK1700
BK0054	2.1/8	300	1650	
BK0056	2.3/16	300	1650	
BK0057	2.1/4	300	1650	
BK0059	2.5/16	345	2450	
BK0060	2.3/8	345	2450	
BK0062	2.7/16	345	2450	
BK0064	2.1/2	355	2700	
BK0065	2.9/16	355	2700	
BK0067	2.5/8	355	2700	
BK0070	2.3/4	365	2850	AK1750
BK0071	2.13/16	365	2850	
BK0075	2.15/16	375	3200	
BK0076	3	375	3200	
BK0079	3.1/8	385	3600	
BK0083	3.1/4	385	3600	
BK0086	3.3/8	385	3600	

AK

**Extention tube**

Aufsteckrohr für Ringzugschlüssel  
 Tube levier pour clé polygonale  
 Extensión para la llave de cajón



Part No.	OD/ID	l mm	g
AK1600	30/22	600	800
AK1700	35/25	700	1450
AK1750	40/30	750	2250

AM  
BM

**Construction open end wrench with pin**

Montageschlüssel mit Dorn  
 Clé à fourche avec pointe  
 Llave de construcción con perno



Part No.	s mm	l mm	g
AM0017	17	320	270
AM0018	18	320	270
AM0019	19	350	465
AM0020	20	350	465
AM0021	21	350	465
AM0022	22	350	465
AM0023	23	370	650
AM0024	24	370	650
AM0025	25	370	650
AM0026	26	370	650
AM0027	27	370	650
AM0028	28	400	950
AM0029	29	400	950
AM0030	30	400	950
AM0032	32	400	950
AM0033	33	400	950
AM0034	34	400	950
AM0035	35	430	1400
AM0036	36	430	1400
AM0037	37	430	1400
AM0038	38	430	1400
AM0041	41	470	1900
AM0042	42	470	1900
AM0046	46	500	2700
AM0047	47	500	2700
AM0050	50	500	3550

Part No.	s inch	l mm	g
BM0018	11/16	320	270
BM0019	3/4	350	465
BM0020	25/32	350	465
BM0021	13/16	350	465
BM0022	7/8	350	465
BM0024	15/16	370	650
BM0025	31/32	370	650
BM0026	1	370	650

Part No.	s inch	l mm	g
BM0027	1.1/16	370	650
BM0029	1.1/8	400	950
BM0030	1.3/16	400	950
BM0032	1.1/4	400	950
BM0033	1.5/16	400	950
BM0035	1.3/8	430	1400
BM0037	1.7/16	430	1400
BM0038	1.1/2	430	1400
BM0039	1.9/16	470	1900
BM0041	1.5/8	470	1900
BM0043	1.11/16	470	1900
BM0044	1.3/4	500	2700
BM0046	1.13/16	500	2700
BM0048	1.7/8	500	2700
BM0051	2	530	3550

AN  
BN

**Construction box wrench offset with pin**

Montageringschlüssel gekröpft  
 Clé fermée à broche, coudée  
 Llave de construcción, acodada con perno



Part No.	s mm	l mm	g
AN0017	17	320	295
AN0018	18	320	295
AN0019	19	350	510
AN0020	20	350	510
AN0021	21	350	510
AN0022	22	350	510
AN0023	23	370	715
AN0024	24	370	715
AN0025	25	370	715
AN0026	26	370	715
AN0027	27	370	715
AN0028	28	400	1145
AN0029	29	400	1145
AN0030	30	400	1145
AN0032	32	400	1145
AN0033	33	400	1145
AN0034	34	400	1145
AN0035	35	430	1540
AN0036	36	430	1540
AN0037	37	430	1540
AN0038	38	430	1540
AN0041	41	470	2090
AN0042	42	470	2090
AN0046	46	500	2970
AN0047	47	500	2970
AN0050	50	530	3900

Part No.	s inch	l mm	g
BN0018	11/16	320	295
BN0019	3/4	350	510
BN0020	25/32	350	510
BN0021	13/16	350	510
BN0022	7/8	350	510



Part No.	s inch	l mm	g
BN0024	15/16	370	715
BN0025	31/32	370	715
BN0026	1	370	715
BN0027	1.1/16	370	715
BN0029	1.1/8	400	1145
BN0030	1.3/16	400	1145
BN0032	1.1/4	400	1145
BN0033	1.5/16	400	1145
BN0035	1.3/8	430	1540
BN0037	1.7/16	430	1540
BN0038	1.1/2	430	1540
BN0039	1.9/16	470	2090
BN0041	1.5/8	470	2090
BN0043	1.11/16	470	2090
BN0044	1.3/4	500	2970
BN0046	1.13/4	500	2970
BN0048	1.7/8	500	2970
BN0051	2	530	3900

AP  
BP**Long handle open end wrench**

Maulzugschlüssel  
Clé à fourche à manche long  
Llave de Boca de mango largo



Part No.	s mm	l mm	g
AP0022	22	320	450
AP0023	23	320	450
AP0024	24	348	600
AP0025	25	348	600
AP0026	26	380	850
AP0027	27	380	850
AP0028	28	416	1050
AP0029	29	416	1050
AP0030	30	416	1050
AP0032	32	453	1350
AP0033	33	453	1350
AP0034	34	453	1350
AP0035	35	497	1700
AP0036	36	497	1700
AP0037	37	497	1700
AP0038	38	497	1700
AP0041	41	546	2350
AP0042	42	546	2350
AP0046	46	600	2800
AP0047	47	600	2800
AP0050	50	662	4000
AP0052	52	662	4000
AP0054	54	662	4000
AP0055	55	730	5300
AP0056	56	730	5300
AP0058	58	805	6850
AP0060	60	805	6850

Part No.	s inch	l mm	g
BP0021	13/16	320	450
BP0022	7/8	320	450
BP0024	15/16	348	600
BP0025	31/32	348	600
BP0026	1	380	850
BP0027	1.1/16	380	850
BP0029	1.1/8	416	1050
BP0030	1.3/16	416	1050
BP0032	1.1/4	416	1050
BP0033	1.5/16	416	1050
BP0035	1.3/8	497	1700
BP0037	1.7/16	497	1700
BP0038	1.1/2	497	1700
BP0039	1.9/16	546	2350
BP0041	1.5/8	546	2350
BP0043	1.11/16	600	2800
BP0044	1.3/4	600	2800
BP0046	1.13/16	600	2800
BP0048	1.7/8	662	4000
BP0051	2	663	4000
BP0052	2.1/16	662	4000
BP0054	2.1/8	730	5300
BP0056	2.3/16	730	5300
BP0057	2.1/4	805	6850
BP0059	2.5/16	805	6850

AT

**Adjustable end wrench**

Rollgabelschlüssel  
Clé à molette  
Llave de cabeza ajustable



Part No.	l inch	l mm	s max mm	g
AT0150	6	150	19	120
AT0200	8	200	24	260
AT0250	10	250	30	400
AT0300	12	300	36	650
AT0380	15	380	45	1300
AT0460	18	450	55	2050
AT0600	24	600	60	4300

AU

**Monkey (railroad) wrench**

Verstellbarer Schraubenschlüssel  
Clé anglaise (chemin de fer)  
Llave Inglesa (Ferrocarri)



Part No.	s max mm	s max inch	l mm	g
AU200	40	1.1/2	200	680
AU245	50	2	245	1005
AU290	60	2.3/8	290	1595
AU360	70	2.3/4	360	2415
AU415	80	3.1/8	415	3800
AU480	105	4	480	5080

CA > DG

SOCKETS  
STECKSCHLÜSSEL  
DOUILLES  
CUBOS



**Sockets, 6 point & deep well**

Steckschlüsseleinsätze, 6-kant & lang  
 Douilles, 6 pans & longues  
 Cubos, 6-puntos & largo

**CA 1/4" Drive**

Part No.	s mm	l mm	g	Part No.	s mm	l mm	g
CA1040	4	22	11	CA2040	4	50	25
CA1045	4.5	22	11	CA2045	4.5	50	25
CA1050	5	22	12	CA2050	5	50	28
CA1055	5.5	22	12	CA2055	5.5	50	28
CA1060	6	22	12	CA2060	6	50	28
CA1070	7	22	13	CA2070	7	50	30
CA1080	8	22	15	CA2080	8	50	34
CA1090	9	22	17	CA2090	9	50	39
CA1100	10	22	18	CA2100	10	50	41
CA1110	11	22	24	CA2110	11	50	55
CA1120	12	22	32	CA2120	12	50	72
CA1130	13	22	32	CA2130	13	50	72
CA1140	14	22	40	CA2140	14	50	90

**DA 1/4" Drive**

Part No.	s inch	l mm	g	Part No.	s inch	l mm	g
DA1048	3/16"	22	12	DA2048	3/16"	50	25
DA1056	7/32	22	12	DA2056	7/32	50	25
DA1064	1/4"	22	12	DA2064	1/4"	50	28
DA1070	9/32	22	13	DA2070	9/32	50	30
DA1080	5/16	22	15	DA2080	5/16	50	34
DA1087	11/32	22	17	DA2087	11/32	50	39
DA1100	3/8	22	18	DA2100	3/8	50	41
DA1120	7/16	22	32	DA2120	7/16	50	72
DA1130	1/2	22	32	DA2130	1/2	50	72
DA1150	9/16	22	40	DA2150	9/16	50	100

**CB 3/8" Drive**

Part No.	s mm	l mm	g	Part No.	s mm	l mm	g
CB1006	6	31	20	CB2006	6	70	45
CB1007	7	31	20	CB2007	7	70	45
CB1008	8	31	20	CB2008	8	70	45
CB1009	9	31	20	CB2009	9	70	45
CB1010	10	31	30	CB2010	10	70	85
CB1011	11	31	40	CB2011	11	70	85
CB1012	12	31	40	CB2012	12	70	85
CB1013	13	31	40	CB2013	13	70	85
CB1014	14	31	50	CB2014	14	70	105
CB1015	15	34	60	CB2015	15	70	120
CB1016	16	34	60	CB2016	16	70	120
CB1017	17	34	60	CB2017	17	70	120
CB1018	18	34	70	CB2018	18	70	140
CB1019	19	34	70	CB2019	19	70	140
CB1020	20	38	80	CB2020	20	70	160
CB1021	21	38	80	CB2021	21	70	160
CB1022	22	38	90	CB2022	22	70	180

**DB 3/8" Drive**

Part No.	s inch	l mm	g	Part No.	s inch	l mm	g
DB1006	1/4"	31	20	DB2006	1/4"	70	45
DB1008	5/16"	31	20	DB2008	5/16"	70	45
DB1010	3/8"	31	30	DB2010	3/8"	70	85
DB1012	7/16"	31	40	DB2012	7/16"	70	85
DB1013	1/2"	31	40	DB2013	1/2"	70	85
DB1014	9/16"	31	50	DB2014	9/16"	70	105
DB1016	5/8"	34	60	DB2016	5/8"	70	120
DB1018	11/16"	34	70	DB2018	11/16"	70	140
DB1019	3/4"	34	70	DB2019	3/4"	70	140
DB1021	13/16"	38	80	DB2021	13/16"	70	160
DB1022	7/8"	38	90	DB2022	7/8"	70	180

**CC 1/2" Drive**

Part No.	s mm	l mm	g	Part No.	s mm	l mm	g
CC1008	8	40	65	CC2008	8	82	125
CC1009	9	40	65	CC2009	9	82	125
CC1010	10	40	75	CC2010	10	82	145
CC1011	11	40	75	CC2011	11	82	145
CC1012	12	40	75	CC2012	12	82	145
CC1013	13	40	75	CC2013	13	82	145
CC1014	14	40	80	CC2014	14	82	150
CC1015	15	40	85	CC2015	15	82	155
CC1016	16	40	85	CC2016	16	82	155
CC1017	17	40	100	CC2017	17	82	185
CC1018	18	40	100	CC2018	18	82	185
CC1019	19	42	110	CC2019	19	82	200
CC1020	20	42	110	CC2020	20	82	200
CC1021	21	42	125	CC2021	21	82	230
CC1022	22	44	140	CC2022	22	82	255
CC1023	23	44	140	CC2023	23	82	255
CC1024	24	46	180	CC2024	24	82	330
CC1025	25	46	180	CC2025	25	82	330
CC1026	26	46	220	CC2026	26	82	400
CC1027	27	48	220	CC2027	27	82	400
CC1028	28	48	230	CC2028	28	82	420
CC1029	29	48	260	CC2029	29	82	475
CC1030	30	50	260	CC2030	30	82	475
CC1032	32	50	260	CC2032	32	82	475

**DC 1/2" Drive**

Part No.	s inch	l mm	g	Part No.	s inch	l mm	g
DC1008	5/16	40	65	DC2008	5/16	82	125
DC1009	3/8	40	75	DC2009	3/8	82	125
DC1011	7/16	40	75	DC2011	7/16	82	145
DC1013	1/2	40	75	DC2013	1/2	82	145
DC1014	9/16	40	75	DC2014	9/16	82	150
DC1015	19/32	40	80	DC2015	19/32	82	155
DC1016	5/8	40	85	DC2016	5/8	82	155
DC1018	11/16	40	100	DC2018	11/16	82	185
DC1019	3/4	42	100	DC2019	3/4	82	200
DC1020	25/32	42	110	DC2020	25/32	82	200
DC1021	13/16	42	110	DC2021	13/16	82	230
DC1022	7/8	44	125	DC2022	7/8	82	255
DC1024	15/16	46	140	DC2024	15/16	82	330
DC1026	1	46	180	DC2026	1	82	400
DC1027	1.1/16	48	220	DC2027	1.1/16	82	400
DC1029	1.1/8	48	230	DC2029	1.1/8	82	475
DC1030	1.3/16	50	230	DC2030	1.3/16	82	475
DC1032	1.1/4	50	260	DC2032	1.1/4	82	475

CD				3/4" Drive			
Part No.	s mm	l mm	g	Part No.	s mm	l mm	g
CD1019	19	50	190	CD2019	19	90	300
CD1022	22	50	230	CD2022	22	90	355
CD1024	24	50	260	CD2024	24	90	400
CD1027	27	55	280	CD2027	27	90	430
CD1030	30	55	300	CD2030	30	90	435
CD1032	32	60	330	CD2032	32	90	480
CD1033	33	60	350	CD2033	33	90	510
CD1034	34	60	350	CD2034	34	90	510
CD1035	35	60	350	CD2035	35	90	540
CD1036	36	65	400	CD2036	36	90	554
CD1037	37	65	400	CD2037	37	90	554
CD1038	38	65	450	CD2038	38	90	690
CD1041	41	65	450	CD2041	41	90	690
CD1042	42	65	550	CD2042	42	90	850
CD1046	46	65	600	CD2046	46	100	925
CD1047	47	65	600	CD2047	47	100	925
CD1050	50	65	700	CD2050	50	100	1080
CD1052	52	65	700	CD2052	52	100	1080
CD1055	55	65	850	CD2055	55	100	1300
CD1060	60	65	1300	CD2060	60	100	2000

DD				3/4" Drive			
Part No.	s inch	l mm	g	Part No.	s inch	l mm	g
DD1019	3/4	50	190	DD2029	3/4	90	300
DD1022	7/8	50	230	DD2022	7/8	90	355
DD1026	1	55	260	DD2026	1	90	400
DD1027	1.1/16	55	280	DD2027	1.1/16	90	430
DD1030	1.3/16	55	300	DD2030	1.3/16	90	480
DD1033	1.5/16	62	350	DD2033	1.5/16	90	510
DD1035	1.3/8	65	350	DD2035	1.3/8	90	540
DD1037	1.7/16	65	400	DD2037	1.7/16	90	615
DD1038	1.1/2	65	450	DD2038	1.1/2	90	690
DD1039	1.9/16	65	450	DD2039	1.9/16	90	690
DD1041	1.5/8	65	450	DD2041	1.5/8	90	690
DD1043	1.11/16	65	550	DD2043	1.11/16	90	850
DD1044	1.3/4	65	550	DD2044	1.3/4	100	850
DD1046	1.13/16	65	600	DD2046	1.13/16	100	925
DD1048	1.7/8	65	600	DD2048	1.7/8	100	925
DD1049	1.15/16	65	700	DD2049	1.15/16	100	1080
DD1051	2	65	700	DD2051	2	100	1080

CE				1" Drive			
Part No.	s mm	l mm	g	Part No.	s mm	l mm	g
CE1036	36	70	685	CE2036	36	100	979
CE1041	41	70	853	CE2041	41	100	1219
CE1046	46	75	1114	CE2046	46	115	1708
CE1050	50	80	1374	CE2050	50	115	1975
CE1055	55	85	1727	CE2055	55	125	2539
CE1060	60	90	2134	CE2060	60	125	2964
CE1065	65	95	2601	CE2065	65	135	3696
CE1070	70	95	2974	CE2070	70	135	4227
CE1075	75	100	3550	CE2075	75	140	4970
CE1080	80	100	3996	CE2080	80	140	5594

DE				1" Drive			
Part No.	s inch	l mm	g	Part No.	s inch	l mm	g
DE1037	1.7/16	70	578	DE2037	1.7/16	100	890
DE1038	1.1/2	70	685	DE2038	1.1/2	100	979
DE1041	1.5/8	70	853	DE2041	1.5/8	100	1219
DE1046	1.13/16	75	1114	DE2046	1.13/16	115	1708
DE1051	2	80	1374	DE2051	2	115	1975
DE1054	2.1/8	85	1727	DE2054	2.1/8	125	2539
DE1060	2.3/8	90	2134	DE2060	2.3/8	125	2964
DE1065	2.9/16	95	2601	DE2065	2.9/16	135	3696
DE1070	2.3/4	95	2974	DE2070	2.3/4	135	4227
DE1075	2.15/16	100	3550	DE2075	2.15/16	140	4970
DE1079	3.1/8	100	3996	DE2079	3.1/8	140	5594

**Ratchet**

Knarre  
Cliquet réversible  
Llave trinquete

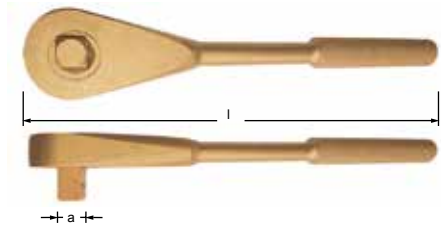

CA				1/4" Drive			
Part No.	a inch	l mm	g				
CA5000	1/4	130	85				

CC				1/2" Drive			
Part No.	a inch	l mm	g				
CC5000	1/2	250	560				

CD				3/4" Drive			
Part No.	a inch	l mm	g				
CD5000	3/4	455	2000				

CE				1" Drive			
Part No.	a inch	l mm	g				
CE5000	1	660	4000				



**Extension bar**

Verlängerungen  
Rallonge  
Barra de extensión

**CA 1/4" Drive**

Part No.	a inch	l mm	g
CA5050	1/4	50	35
CA5100	1/4	100	55
CA5150	1/4	150	100

**CC 1/2" Drive**

Part No.	a inch	l mm	g
CC5075	1/2	75	130
CC5125	1/2	125	225
CC5250	1/2	250	420

**CD 3/4" Drive**

Part No.	a inch	l mm	g
CD5095	3/4	95	155
CD5200	3/4	200	480
CD5400	3/4	400	1250

**CE 1" Drive**

Part No.	a inch	l mm	g
CE5200	1	200	1050
CE5400	1	400	2000

**Sliding T bar**

T - Gleitgriff  
Poignée coulissante  
Barra deslizante

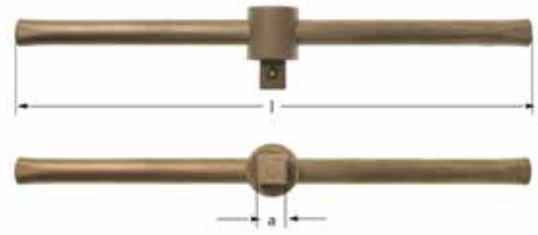
**CA 1/4" Drive**

Part No.	a inch	l mm	g
CA5820	1/4	115	55

**CC 1/2" Drive**

Part No.	a inch	l mm	g
CC5820	1/2	290	500

**CD 3/4" Drive**

Part No.	a inch	l mm	g
CD5820	3/4	500	1200

**CE 1" Drive**

Part No.	a inch	l mm	g
CE5820	1	700	3000

**Hinged handle**

Gelenkgriff  
Poignée articulée  
Mango de cabeza deslizante

**CA 1/4" Drive**

Part No.	a inch	l mm	g
CA5800	1/4	150	85

**CC 1/2" Drive**

Part No.	a inch	l mm	g
CC5800	1/2	305	930

**CD 3/4" Drive**

Part No.	a inch	l mm	g
CD5800	3/4	500	1300

**Universal joint**

Kardangelenk  
Cardan  
universal conexión universal

**CA 1/4" Drive**

Part No.	a inch	l mm	g
CA5840	1/4	33	25

**CC 1/2" Drive**

Part No.	a inch	l mm	g
CC5840	1/2"	75	190

**CD 3/4" Drive**

Part No.	a inch	l mm	g
CD5840	3/4"	90	350

**CE 1" Drive**

Part No.	a inch	l mm	g
CE5840	1	120	1350

**CC**
**Speed handle**

 Winde  
 Manivelle  
 Manivela

1/2"-3/4" Drive

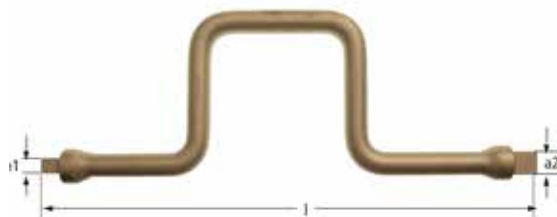

Part No.	a1 inch	a2 inch	l mm	g
CC5860	1/2	3/4	410	1350

**Adapter, Converter**

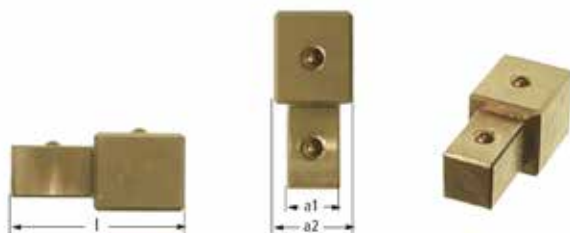
 Übergangsteil  
 Réducteur  
 Adaptador para trinquete

**CA**
**1/4" Drive**

Part No.	a1 inch	a2 inch	l mm	g
CA5893	1/4	1/2	24	36

**CC**
**1/2" Drive**

Part No.	a1 inch	a2 inch	l mm	g
CC5893	1/2	3/4	42	80

**CD**
**3/4" Drive**

Part No.	a1 inch	a2 inch	l mm	g
CD5893	3/4	1	45	380

**Socket sets, 6 point**

 Steckschlüssel-Garnitur  
 6-kant Jeu de douilles, 6 pans  
 Juego de cubos, 6-puntos

**CA  
DA**
**1/4" Drive**

Part No.	s mm	g	parts
CA9000	4, 4.5, 5, 5.5, 6, 7, 8, 9, 10, 11, 12, 13, 14	980	Ratchet, extension bar 100 mm, sliding T bar, universal joint.

DA9000	3/16, 7/32, 1/4, 9/32, 5/16, 11/32, 3/8, 7/16, 1/2, 9/16	900	Ratchet, extension bar 100 mm, sliding T bar, universal joint.
--------	--	-----	--

**CC  
DC**
**1/2" Drive**

Part No.	s mm	g	parts
CC9000	8, 9, 10, 11, 12, 13, 14, 15, 16, 17, 18, 19, 20, 21, 22, 23, 24, 25, 26, 27, 28, 29, 30, 32	7200	Ratchet, extension bar 75 & 250mm, sliding T bar, hinged handle, universal joint.
DC9000	5/16, 3/8, 7/16, 1/2, 9/16, 19/32, 5/8, 11/16, 3/4, 25/32, 13/16, 7/8, 15/16, 1, 1.1/16, 1.1/8, 1.1/4	6900	Ratchet, extension bar 75 & 250mm, sliding T bar, hinged handle, universal joint.

**CD  
DD**
**3/4" Drive**

Part No.	s mm	g	parts
CD9000	19, 22, 24, 27, 30, 32, 36, 38, 41, 46, 50, 55, 60	15200	Ratchet, extension bar 200 & 400mm, sliding T bar, hinged handle, universal joint.
DD9000	1.5/16, 1.3/8, 1.7/16, 1.1/2, 1.9/16, 1.5/8, 1.11/16, 1.3/4, 1.13/16, 1.7/8, 2	14150	Ratchet, extension bar 200 & 400mm, sliding T bar, hinged handle, universal joint.

**CE  
DE**
**1" Drive**

Part No.	s mm	g	parts
CE9000	36, 41, 46, 50, 55, 60, 65, 70, 75, 80	37400	Ratchet, extension bar 200 & 400mm, sliding T bar, universal joint.
DE9000	1.7/16, 1.5/8, 1.13/16, 2, 2.1/8, 2.3/8, 2.9/16, 2.3/4, 2.15/16, 3.1/8	37300	Ratchet, extension bar 200 & 400mm, sliding T bar, universal joint.

**Impact sockets, 6 point & deep well**

Schlagschraubereinsätze, 6-kant & lang  
 Douilles impact, 6 pans & longues  
 Cubos impact, 6-puntos & largo

**CC 1/2" Drive**

Part No.	s mm	l mm	g	Part No.	s mm	l mm	g
CC3008	8	42	65	CC4008	8	82	125
CC3009	9	42	65	CC4009	9	82	125
CC3010	10	42	75	CC4010	10	82	145
CC3011	11	42	75	CC4011	11	82	145
CC3012	12	44	75	CC4012	12	82	145
CC3013	13	44	75	CC4013	13	82	145
CC3014	14	44	80	CC4014	14	82	150
CC3015	15	44	85	CC4015	15	82	155
CC3016	16	44	85	CC4016	16	82	155
CC3017	17	44	100	CC4017	17	82	185
CC3018	18	44	100	CC4018	18	82	185
CC3019	19	44	110	CC4019	19	82	200
CC3020	20	44	110	CC4020	20	82	200
CC3021	21	44	125	CC4021	21	82	230
CC3022	22	44	140	CC4022	22	82	255
CC3023	23	44	140	CC4023	23	82	255
CC3024	24	46	180	CC4024	24	82	330
CC3025	25	46	180	CC4025	25	82	330
CC3026	26	46	220	CC4026	26	82	400
CC3027	27	48	220	CC4027	27	82	400
CC3028	28	48	230	CC4028	28	82	420
CC3029	29	48	260	CC4029	29	82	475
CC3030	30	50	260	CC4030	30	82	475
CC3032	32	50	260	CC4032	32	82	475

**DC 1/2" Drive**

Part No.	s inch	l mm	g	Part No.	s inch	l mm	g
DC3008	5/16	42	65	DC4008	5/16	82	125
DC3009	3/8	42	75	DC4009	3/8	82	125
DC3011	7/16	42	75	DC4011	7/16	82	145
DC3013	1/2	44	75	DC4013	1/2	82	145
DC3014	9/16	44	75	DC4014	9/16	82	150
DC3015	19/32	44	80	DC4015	19/32	82	155
DC3016	5/8	44	85	DC4016	5/8	82	155
DC3018	11/16	44	100	DC4018	11/16	82	185
DC3019	3/4	44	100	DC4019	3/4	82	200
DC3020	25/32	44	110	DC4020	25/32	82	200
DC3021	13/16	44	110	DC4021	13/16	82	230
DC3022	7/8	44	125	DC4022	7/8	82	255
DC3024	15/16	44	140	DC4024	15/16	82	330
DC3026	1	46	180	DC4026	1	82	400
DC3027	1.1/16	48	220	DC4027	1.1/16	82	400
DC3029	1.1/8	48	230	DC4029	1.1/8	82	475
DC3030	1.3/16	50	230	DC4030	1.3/16	82	475
DC3032	1.1/4	50	260	DC4032	1.1/4	82	475

**CD 3/4" Drive**

Part No.	s mm	l mm	g	Part No.	s mm	l mm	g
CD3019	19	55	190	CD4019	19	90	300
CD3022	22	55	230	CD4022	22	90	355
CD3024	24	55	260	CD4024	24	90	400
CD3027	27	55	280	CD4027	27	90	430
CD3030	30	62	300	CD4030	30	95	460
CD3032	32	62	330	CD4032	32	95	480
CD3034	34	62	350	CD4034	34	95	510
CD3036	36	65	400	CD4036	36	95	585
CD3041	41	65	450	CD4041	41	100	690
CD3046	46	65	600	CD4046	46	100	925
CD3050	50	65	700	CD4050	50	100	1080
CD3055	55	65	850	CD4055	55	100	1300
CD3060	60	65	1300	CD4060	60	100	2000

**DD 3/4" Drive**

Part No.	s inch	l mm	g	Part No.	s inch	l mm	g
DD3019	3/4	55	190	DD4019	3/4	90	300
DD3022	7/8	55	230	DD4022	7/8	90	355
DD3026	1	55	260	DD4026	1	90	400
DD3027	1.1/16	55	280	DD4027	1.1/16	90	430
DD3030	1.3/16	62	300	DD4030	1.3/16	95	480
DD3033	1.5/16	62	350	DD4033	1.5/16	95	510
DD3035	1.3/8	65	350	DD4035	1.3/8	95	540
DD3037	1.7/16	65	400	DD4037	1.7/16	95	615
DD3038	1.1/2	65	450	DD4038	1.1/2	100	690
DD3041	1.5/8	65	450	DD4041	1.5/8	100	690
DD3044	1.3/4	65	550	DD4044	1.3/4	100	850
DD3048	1.7/8	65	600	DD4048	1.7/8	100	925
DD3051	2	65	700	DD4051	2	100	1080

**CE 1" Drive**

Part No.	s mm	l mm	g	Part No.	s mm	l mm	g
CE3030	30	65	557	CE4030	30	100	857
CE3032	32	65	614	CE4032	32	100	944
CE3034	34	65	673	CE4034	34	100	1035
CE3036	36	70	792	CE4036	36	100	1131
CE3041	41	70	972	CE4041	41	100	1388
CE3046	46	75	1254	CE4046	46	115	1922
CE3050	50	80	1534	CE4050	50	115	2205
CE3055	55	85	1911	CE4055	55	125	2810
CE3060	60	90	2345	CE4060	60	125	3257
CE3065	65	95	2839	CE4065	65	135	4035
CE3070	70	95	3229	CE4070	70	135	4588
CE3075	75	100	3835	CE4075	75	140	5369
CE3080	80	100	4297	CE4080	80	140	6016

**DE 1" Drive**

Part No.	s inch	l mm	g	Part No.	s inch	l mm	g
DE3029	1.1/8	65	557	DE4029	1.1/8	100	857
DE3032	1.1/4	65	614	DE4032	1.1/4	100	944
DE3033	1.5/16	65	673	DE4033	1.5/16	100	1035
DE3038	1.1/2	70	792	DE4038	1.1/2	100	1131
DE3041	1.5/8	70	972	DE4041	1.5/8	100	1388
DE3046	1.13/16	75	1254	DE4046	1.13/16	115	1922
DE3051	2	80	1534	DE4051	2	115	2205
DE3054	2.1/8	85	1911	DE4054	2.1/8	125	2810
DE3060	2.3/8	90	2345	DE4060	2.3/8	125	3257
DE3065	2.9/16	95	2839	DE4065	2.9/16	135	4035
DE3070	2.3/4	95	3229	DE4070	2.3/4	135	4588
DE3075	2.15/16	95	3835	DE4075	2.15/16	140	5369
DE3079	3.1/8	95	4297	DE4079	3.1/8	140	6016

CF				1 1/2" Drive			
Part No.	s mm	l mm	g	Part No.	s mm	l mm	g
CF3036	36	80	1082	CF4036	36	120	1664
CF3041	41	80	1336	CF4041	41	120	2004
CF3046	46	85	1663	CF4046	46	150	2970
CF3050	50	90	1955	CF4050	50	150	3370
CF3055	55	90	2343	CF4055	55	150	3906
CF3060	60	95	2838	CF4060	60	150	4481
CF3065	65	100	3397	CF4065	65	150	5095
CF3070	70	105	4025	CF4070	70	170	6516
CF3075	75	110	4725	CF4075	75	170	7302
CF3080	80	115	5550	CF4080	80	180	8611
CF3085	85	120	6359	CF4085	85	180	9539
CF3090	90	125	7418	CF4090	90	180	10513
CF3095	95	127	8139	CF4095	95	180	11535
CF3100	100	130	9103	CF4100	100	180	12604
CF3105	105	130	9910	CF4105	105	190	14483

DF				1 1/2" Drive			
Part No.	s inch	l mm	g	Part No.	s inch	l mm	g
DF3035	1.3/8	80	1082	DF4035	1.3/8	120	1664
DF3041	1.5/8	80	1336	DF4041	1.5/8	120	2004
DF3046	1.13/16	85	1663	DF4046	1.13/16	150	2970
DF3051	2	90	1955	DF4051	2	150	3370
DF3054	2.1/8	90	2343	DF4054	2.1/8	150	3906
DF3060	2.3/8	95	2838	DF4060	2.3/8	150	4481
DF3065	2.9/16	100	3397	DF4065	2.9/16	150	5095
DF3070	2.3/4	105	4025	DF4070	2.3/4	170	6516
DF3075	2.15/16	110	4725	DF4075	2.15/16	170	7302
DF3079	3.1/8	115	5550	DF4079	3.1/8	180	8611
DF3086	3.3/8	120	6359	DF4086	3.3/8	180	9539
DF3089	3.1/2	125	7418	DF4089	3.1/2	180	10513
DF3095	3.3/4	127	8139	DF4095	3.3/4	180	11535
DF3100	3.15/16	130	9103	DF4100	3.15/16	180	12604
DF3104	4.1/8	130	9910	DF4104	4.1/8	190	14483

CG				2 1/2" Drive			
Part No.	s mm	l mm	g	Part No.	s mm	l mm	g
CG3075	75	140	6653	CG4075	75	180	8553
CG3080	80	140	7371	CG4080	80	180	9478
CG3085	85	140	8127	CG4085	85	180	10449
CG3090	90	150	9557	CG4090	90	200	12742
CG3095	95	150	10445	CG4095	95	200	13927
CG3100	100	150	11373	CG4100	100	200	15164
CG3105	105	150	12341	CG4105	105	220	18099
CG3110	110	150	13348	CG4110	110	220	19576
CG3115	115	150	14394	CG4115	115	220	21111
CG3120	120	150	15480	CG4120	120	220	22704
CG3125	125	150	16605	CG4125	125	220	24355

DG				2 1/2" Drive			
Part No.	s inch	l mm	g	Part No.	s inch	l mm	g
DG3075	2.15/16	140	6653	DG4075	2.15/16	180	8553
DG3079	3.1/8	140	7371	DG4079	3.1/8	180	9478
DG3086	3.3/8	140	8127	DG4086	3.3/8	180	10449
DG3089	3.1/2	150	9557	DG4089	3.1/2	200	12742
DG3095	3.3/4	150	10445	DG4095	3.3/4	200	13927
DG3100	3.15/16	150	11373	DG4100	3.15/16	200	15164
DG3104	4.1/8	150	12341	DG4104	4.1/8	220	18099
DG3110	4.5/16	150	13348	DG4110	4.5/16	220	19576
DG3114	4.1/2	150	14394	DG4114	4.1/2	220	21111
DG3121	4.3/4	150	15480	DG4121	4.3/4	220	22704
DG3125	4.15/16	150	16605	DG4125	4.15/16	220	24355

**Impact extension bar**

Verlängerungen für Schlagschrauber  
Rallonge impact  
Barras de extensión impact



CC				1/2" Drive			
Part No.	a inch	l mm	g	Part No.	a inch	l mm	g
CC7075	1/2	75	155	CC7125	1/2	125	260

CD				3/4" Drive			
Part No.	a inch	l mm	g	Part No.	a inch	l mm	g
CD7125	3/4	125	385	CD7250	3/4	250	530

CE				1" Drive			
Part No.	a inch	l mm	g	Part No.	a inch	l mm	g
CE7150	1	150	910	CE7300	1	300	1650

**Impact universal joint**

Kardangelen für Schlagschrauber  
Cardan universel impact  
Conexión universal impact



CC				1/2" Drive			
Part No.	a inch	l mm	g	Part No.	a inch	l mm	g
CC7840	1/2	60	210				

CD				3/4" Drive			
Part No.	a inch	l mm	g	Part No.	a inch	l mm	g
CD7840	3/4	108	370				

CE				1" Drive			
Part No.	a inch	l mm	g	Part No.	a inch	l mm	g
CE7840	1	113	1500				



**CH > CY**

SPECIAL KEYS  
ZONDERE SCHLÜSSEL  
CLÉS SPÉCIALES  
LLAVES ESPECIALES



CH  
DH**Hex key / Allen key**Sechskant-Winkelschraubendreher (Inbus)  
Clé mâle pour vis creuse à 6 pans  
Llave hexagonal, allen

DIN 911

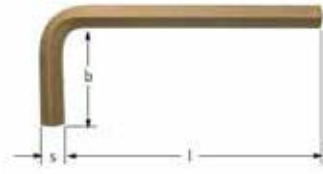

Part No.	s mm	b mm	l mm	g
CH0015	1.5	19	45	2
CH0020	2	19	45	2
CH0025	2.5	20	65	4
CH0030	3	20	65	5
CH0040	4	25	72	11
CH0050	5	28	80	19
CH0060	6	32	90	30
CH0070	7	32	90	45
CH0080	8	36	100	60
CH0090	9	36	109	90
CH0100	10	40	112	105
CH0110	11	40	112	105
CH0120	12	45	125	170
CH0140	14	55	140	260
CH0170	17	60	160	444
CH0190	19	70	175	618
CH0220	22	80	200	950
CH0240	24	90	224	1260
CH0270	27	110	250	1780
CH0300	30	112	280	2460
CH0320	32	125	315	3140
CH0360	36	140	355	4470

Part No.	s inch	b mm	l mm	g
DH0016	1/16	19	45	5
DH0020	3/32	19	45	9
DH0024	5/64	19	45	9
DH0032	1/8	21	60	9
DH0040	5/32	22	64	9
DH0048	3/16	22	73	18
DH0056	7/32	28	80	27
DH0064	1/4	28	98	36
DH0080	5/16	36	104	64
DH0090	3/8	38	104	109
DH0110	7/16	44	131	163
DH0130	1/2	44	131	209
DH0140	9/16	44	144	281
DH0160	5/8	48	158	390
DH0180	11/16	57	185	544
DH0190	3/4	57	185	644
DH0220	7/8	57	185	898
DH0260	1	57	185	1179

CH  
DH**Sets**Sätze  
Jeux  
Juego

Part No.	parts	b mm	g
CH1007	7pcs	1.5,2,2.5,3,4,5,6	130
CH1009	9pcs	1.5,2,2.5,3,4,5,6,8,10	535

Part No.	parts	b inch	g
DH1006	6pcs	1/16,5/64,3/32,1/8,5/32,3/16	130
DH1009	9pcs	1/8,5/32,3/16,7/32,1/4,5/16 3/8,7/16,1/2	535

CJ  
DJ**Ballpoint hex driver, long arm**Sechskant - Winkelschraubendreher, lang, mit Kugelkopf  
Clé mâle longue à tête sphérique  
Llave hexagonal, larga, cabeza esférica

Part No.	s mm	b mm	l mm	g
CJ0020	2	16	75	2
CJ0025	2.5	18	85	4
CJ0030	3	20	90	7
CJ0040	4	25	100	15
CJ0050	5	28	115	24
CJ0060	6	32	135	42
CJ0070	7	34	140	57
CJ0080	8	36	150	80
CJ0090	9	38	160	110
CJ0100	10	40	170	140

Part No.	s inch	b mm	l mm	g
DJ0020	3/32	16	75	2
DJ0024	5/64	18	85	4
DJ0032	1/8	20	90	7
DJ0040	5/32	25	100	15
DJ0048	3/16	28	115	24
DJ0056	7/32	32	135	42
DJ0064	1/4	34	140	57
DJ0080	5/16	36	150	80
DJ0090	3/8	38	160	110
DJ0110	7/16	40	170	140

CL  
DL**Socket wrench 6 point**Steckschlüssel, 6-Kant  
Clé à douille, 6 pans  
Llave para cubo, 6-Puntos

DIN 911



Part No.	s mm	l mm	g	Bar	d mm	l mm
CL0008	8	190	110			
CL0009	9	200	135			
CL0010	10	215	160	CL0150	6	150
CL0011	11	230	210			
CL0012	12	250	260			
CL0013	13	265	350	CL0180	8	180
CL0014	14	265	350			
CL0015	15	280	400			
CL0016	16	280	400	CL0200	10	200
CL0017	17	300	450			
CL0018	18	300	450			
CL0019	19	325	650			
CL0020	20	325	650	CL0230	10	230
CL0021	21	350	830			
CL0022	22	350	830			
CL0023	23	380	1140			
CL0024	24	380	1140	CL0250	13	250
CL0025	25	415	1450			
CL0026	26	415	1450	CL0320	13	320
CL0027	27	415	1450			
CL0028	28	190	1800			
CL0029	29	200	1800			
CL0030	30	215	1800	CL0400	16	400
CL0032	32	230	2450			
CL0033	33	250	2450			
CL0034	34	265	2450			
CL0035	35	530	3300			
CL0036	36	530	3300			
CL0037	37	530	3300	CL0500	16	500
CL0038	38	530	3300			
CL0041	41	580	4000			
CL0042	42	580	4000			
CL0046	46	635	4800	CL0630	20	630
CL0047	47	635	4800			
CL0050	50	320	4900			
CL0052	52	320	4900			
CL0054	54	340	6500			
CL0055	55	340	6500	CL0710	25	710
CL0056	56	340	6500			
CL0058	58	360	8300			
CL0060	60	360	8300			
CL0063	63	360	8300			
CL0065	65	380	10500			
CL0067	67	380	10500			
CL0070	70	380	10500			
CL0071	71	380	10500	CL0800	32	800
CL0075	75	400	14300			
CL0077	77	400	14300			
CL0080	80	400	14300			
CL0082	82	400	14300			

Part No.	s mm	l mm	g	Bar	d mm	l mm
CL0085	85	425	19200			
CL0088	88	425	19200			
CL0090	90	425	19200	CL1000	38	1000
CL0094	94	455	26000			
CL0095	95	455	26000			
CL0100	100	455	26000			

Part No.	s inch	l mm	g	Bar	d mm	l mm
DL0008	5/16	190	110			
DL0009	3/8	200	160	CL0150	6	150
DL0010	13/32	215	210			
DL0011	7/16	230	260			
DL0013	1/2	265	350	CL0180	8	180
DL0014	9/16	265	350			
DL0015	19/32	280	400			
DL0016	5/8	280	400	CL0200	10	200
DL0018	11/16	300	450			
DL0019	3/4	325	650			
DL0020	25/32	325	650	CL0230	10	230
DL0021	13/16	350	830			
DL0022	7/8	350	830			
DL0024	15/16	380	1140			
DL0025	31/32	415	1450	CL0250	12.7	250
DL0026	1	415	1450	CL0320	12.7	320
DL0027	1.1/16	450	1800			
DL0029	1.1/8	450	1800			
DL0030	1.3/16	450	1800			
DL0032	1.1/4	485	2450	CL0400	15.9	400
DL0033	1.5/16	485	3300			
DL0035	1.3/8	530	3300			
DL0037	1.7/16	530	3300			
DL0038	1.1/2	580	4000			
DL0039	1.9/16	580	4000	CL0500	15.9	500
DL0041	1.5/8	580	4000			
DL0043	1.11/16	580	4000			
DL0044	1.3/4	635	4800			
DL0046	1.13/16	635	4800	CL0630	20.6	630
DL0048	1.7/8	635	4800			
DL0051	2	320	4900			
DL0052	2.1/16	320	4900			
DL0054	2.1/8	340	6500			
DL0056	2.3/16	340	6500	CL0710	25.4	710
DL0057	2.1/4	340	6500			
DL0059	2.5/16	360	8300			
DL0060	2.3/8	360	8300			
DL0062	2.7/16	360	8300			
DL0064	2.1/2	380	10500			
DL0065	2.9/16	380	10500			
DL0067	2.5/8	380	10500			
DL0070	2.3/4	380	10500			
DL0071	2.13/16	380	10500	CL0800	32	800
DL0075	2.15/16	400	14300			
DL0076	3	400	14300			
DL0079	3.1/8	400	14300			
DL0083	3.1/4	400	14300			
DL0086	3.3/8	425	19200			
DL0089	3.1/2	425	19200			
DL0092	3.5/8	455	19200	CL1000	38	1000
DL0095	3.3/4	455	26000			
DL0098	3.7/8	455	26000			

CN  
DN**Socket wrench L-type, 6 point**

Steckschlüssel, gewinkelt, 6-kant  
Clé à pipe, 6 pans  
Llave para cubo, tipo-L, 6-puntos



Part No.	s mm	b mm	l mm	g
CN0008	8	33	175	100
CN0009	9	35	185	120
CN0010	10	37	195	140
CN0011	11	39	205	180
CN0012	12	42	220	220
CN0013	13	45	240	280
CN0014	14	45	240	280
CN0015	15	48	250	300
CN0016	16	48	250	300
CN0017	17	51	270	320
CN0018	18	51	270	320
CN0019	19	55	290	530
CN0020	20	55	290	530
CN0021	21	59	310	680
CN0022	22	59	310	680
CN0023	23	63	335	830
CN0024	24	63	335	830
CN0025	25	69	365	1000
CN0026	26	69	365	1000
CN0027	27	69	365	1000
CN0028	28	75	395	1300
CN0029	29	75	395	1300
CN0030	30	75	395	1300
CN0032	32	81	425	1700
CN0033	33	81	425	1700
CN0034	34	81	425	1700
CN0035	35	89	465	2800
CN0036	36	89	465	2800
CN0037	37	89	465	2800
CN0038	38	89	465	2800
CN0041	41	96	510	3600
CN0042	42	96	510	3600
CN0046	46	105	555	4000
CN0047	47	105	555	4000
CN0050	50	114	605	4800
CN0052	52	114	605	4800
CN0054	54	120	660	6400
CN0055	55	120	660	6400
CN0056	56	120	660	6400
CN0058	58	138	730	8200
CN0060	60	138	730	8200
CN0063	63	138	730	8200
CN0065	65	150	800	10400
CN0067	67	150	800	10400
CN0070	70	150	800	10400
CN0071	71	150	800	10400
CN0075	75	166	880	14100
CN0077	77	166	880	14100
CN0080	80	166	880	14100
CN0082	82	166	880	14100

Part No.	s inch	b mm	l mm	g
DN0008	5/16	33	175	100
DN0009	3/8	37	195	140
DN0010	13/32	39	205	180
DN0011	7/16	42	220	220
DN0013	1/2	45	240	280
DN0014	9/16	45	240	280
DN0015	19/32	48	250	300
DN0016	5/8	48	250	300
DN0018	11/16	51	270	320
DN0019	3/4	55	290	530
DN0020	25/32	55	290	530
DN0021	13/16	59	310	680
DN0022	7/8	59	310	680
DN0024	15/16	63	335	830
DN0025	31/32	69	365	1000
DN0026	1	69	365	1000
DN0027	1.1/16	75	395	1300
DN0029	1.1/8	75	395	1300
DN0030	1.3/16	75	395	1300
DN0032	1.1/4	81	425	1700
DN0033	1.5/16	81	425	1700
DN0035	1.3/8	89	465	2800
DN0037	1.7/16	89	465	2800
DN0039	1.1/2	89	465	2800
DN0040	1.9/16	96	510	3600
DN0042	1.5/8	96	510	3600
DN0043	1.11/16	96	510	3600
DN0044	1.3/4	105	555	4000
DN0046	1.13/16	105	555	4000
DN0048	1.7/8	105	555	4000
DN0051	2	114	605	4800
DN0052	2.1/16	114	605	4800
DN0054	2.1/8	120	660	6400
DN0056	2.3/16	120	660	6400
DN0057	2.1/4	120	660	6400
DN0059	2.5/16	138	730	8200
DN0060	2.3/8	138	730	8200
DN0062	2.7/16	138	730	8200
DN0064	2.1/2	150	800	10400
DN0065	2.9/16	150	800	10400
DN0067	2.5/8	150	800	10400
DN0070	2.3/4	150	800	10400
DN0071	2.13/16	150	800	10400
DN0075	2.15/16	166	880	14100
DN0076	3	166	880	14100
DN0079	3.1/8	166	880	14100
DN0083	3.1/4	166	880	14100



CS

**Socket wrench 3 point, for switch-board**

Dreikantsteckschlüssel  
Clé à douille 3 pans, pour boîte de distribution  
Llave para cubo, 3-puntos, armario eléctrico

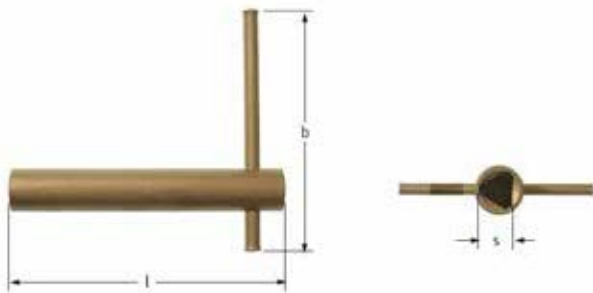

Part No.	s mm	b mm	l mm	g
CS0004	M4	50	90	70
CS0005	M5	68	100	105
CS0006	M6	86	112	180
CS0008	M8	105	125	270
CS0010	M10	130	140	420
CS0012	M12	206	160	660
CS0016	M16	206	180	1150
CS0020	M20	250	200	1900
CS0024	M24	315	224	3300

CT  
DT**Hex nut driver**

Mutterdreher  
Clé à douille pour boulons à six pans  
Dirigidor de tuercas hexagonales

DIN 894



Part No.	s mm	b mm	l mm	g
CT0035	3.5	85	175	55
CT0040	4	85	180	55
CT0045	4.5	85	180	60
CT0050	5	85	185	60
CT0055	5.5	90	190	65
CT0060	6	90	190	65
CT0065	6.5	90	190	80
CT0070	7	100	200	80
CT0075	7.5	100	200	100
CT0080	8	100	210	100
CT0090	9	100	210	115
CT0100	10	110	220	115
CT0110	11	110	220	130
CT0120	12	110	230	170
CT0130	13	110	230	210
CT0140	14	120	240	210
CT0150	15	120	240	235
CT0160	16	130	250	235
CT0170	17	130	250	240

Part No.	s inch	b mm	l mm	g
DT0031	1/8	85	175	55
DT0040	5/32	85	180	55
DT0048	3/16	85	185	60
DT0056	7/32	90	190	65
DT0064	1/4	90	190	80
DT0080	5/16	100	210	100
DT0100	3/8	110	220	115
DT0120	7/16	110	230	170
DT0130	1/2	110	230	210
DT0150	9/16	120	240	235
DT0160	5/8	130	250	235
DT0170	11/16	130	250	240

CV

**Hook spanner, fixed/adjustable hook**

Hakenschlüssel / Gelenkhakenschlüssel

Clé à ergot / à ergot articulé

DIN 1810

Llave de gancho / de gancho ajustable

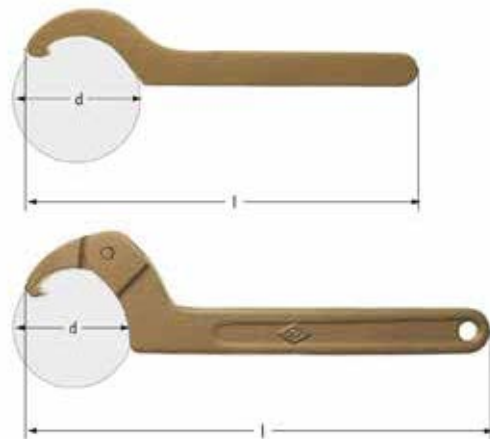

Part No.	d mm	d inch	l mm	g
CV0014	12-14	15/32-9/16	110	30
CV0020	16-20	5/8-13/16	110	30
CV0028	25-28	31/32-1.1/8	136	50
CV0032	30-32	1.3/16-1.1/4	136	50
CV0036	34-36	1.5/16-1.7/16	170	100
CV0042	40-42	1.9/16-1.11/16	170	100
CV0050	45-50	1.3/4-2	205	190
CV0055	52-55	2.1/16-2.3/16	205	190
CV0062	58-62	2.1/4-2.7/16	245	265
CV0075	68-75	2.11/16-2	245	265
CV0090	80-90	3.1/8-3.1/2	285	410
CV0100	95-100	3.3/4-4	285	410
CV0115	110-115	3.5/16-4.9/16	335	730
CV0130	120-130	4.11/16-5.1/8	335	730
CV0145	135-145	5.5/16-5.3/4	385	1150
CV0165	155-165	6.1/8-6.1/2	385	1150
CV2000	32-75	1.1/4-3	205	230
CV2100	50-120	2-4.3/4	285	450
CV2200	115-170	4.1/2-6.3/4	310	500

**CW****Hose coupling wrench**Kupplungsschlüssel  
Clé pour raccord de tuyau  
Llave de ansas acopladas

DIN 14822

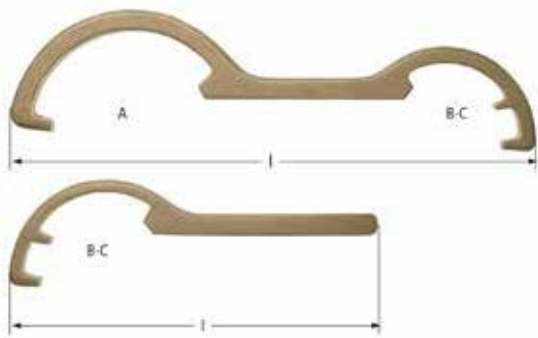

Part No.	d mm	d inch	l mm	g
CW1000	A,B-C	110-75-52	455	1100
CW2000	B-C	75-52	285	460

**CX****Valve wheel key**Handradschlüssel  
Clé à volant  
Llave giradora de válvulas

DIN 87311



Part No.	d mm	d max mm	a mm	l mm	g
CX5000	36	180	60	370	650
CX5100	48	400	80	430	1300
CX5200	62	720	102	550	2550

**CX****Valve wheel hook**Ventilhaken  
Clé à valve  
Gancho girador de válvulas

Part No.	a mm	b mm	l mm	g
CX0300	30	56	300	350
CX0350	35	61	350	600
CX0400	40	72	400	680
CX0450	45	77	450	1110
CX0500	50	88	500	1200
CX0600	60	104	600	2000
CX0700	70	120	700	3000
CX0800	80	136	800	4230
Part No.	a1x2 mm	b mm	l mm	g
CX2000	30x40	113	500	720

**CY****Multi-head bung wrench**Universalfassschlüssel  
Clé universelle pour débonder les fûts  
Llave taponadora universal

Part No.	l mm	g
CY1000	385	1300



Part No.	l mm	g
CY2000	305	680





EA > EU

PLIERS  
ZANGE  
PINCES  
ALICATES





EA

**Pliers, combination, with cutter**

Kombinationszange  
Pince universelle  
Alicate universal

DIN 5244  
ISO 5746



Part No.	p mm	l mm	g
EA1700	13	170	285
EA2000	15	200	343

EE

**Pliers, long nose, with cutter**

Telefonzange  
Pince demi-ronde, long bec  
Alicate de punta larga con cortador

ISO 5745



Part No.	p mm	l mm	g
EE1500	9	160	105
EE1800	10	200	290

EB

**Pliers, adjustable combination**

Verstellbare Kombinationszange  
Pince combinée  
Alicate ajustable

ISO 9343

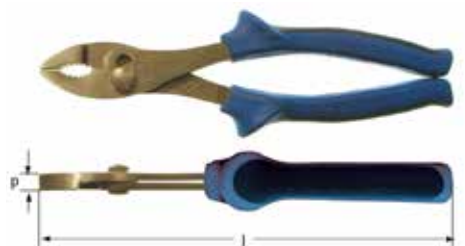

Part No.	d max inch	d max mm	p mm	l mm	g
EB2050	1	25	12	205	285

EF

**Pliers, flat nose**

Flachzange  
Pince plate  
Alicate de punta aplanada

DIN 5248  
ISO 5745



Part No.	p mm	l mm	g
EF1600	8	160	105

EC

**Pliers, groove joint**

Wasserpumpenzange  
Pince multiprise  
Pinza junta estrila

DIN 5231 F  
ISO 8976



Part No.	a max inch	a max mm	p mm	l mm	g
EC2500	1.1/2	40	10	250	380
EC3000	2.1/8	50	12	300	635
EC4000	3.3/8	85	14	400	1195

EG

**Pliers, round nose**

Rundzange  
Pince becs ronds  
Alicate, bocas redondas

DIN 5249  
ISO 5745



Part No.	p mm	l mm	g
EG1550	8	160	105

**EH** **Pliers, snap ring, outside**  
 Sicherungsringszange (Außen)  
 Pince pour circlips extérieurs  
 Pinza abre anillos exteriores **DIN 5254**

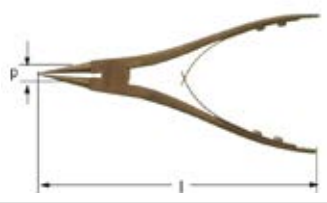

Part No.	Ring dia mm	p mm	l mm	g
EH0140	3-10	7	140	85
EH1140	10-25	7	140	85
EH2180	19-60	9	180	125
EH3225	40-100	11	225	245
EH4305	85-165	14	305	520
EH5500	125-300	17	500	1225

**EL** **Pliers, wire stripping**  
 Abisolierzange  
 Pince à dénuder  
 Pinza quita alambre

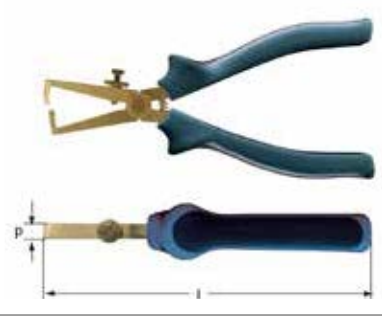

Part No.	Ring dia mm	p mm	l mm	g
EL1550	0.5-5	8	155	122

**EJ** **Pliers, snap ring, inside**  
 Sicherungsringszange (Innen)  
 Pince pour circlips intérieurs  
 Pinza abre anillos interiores **ISO 5256**



Part No.	Ring dia mm	p mm	l mm	g
EJ1140	8-25	7	140	65
EJ2180	19-60	9	180	135
EJ3220	40-100	11	220	250
EJ4270	85-165	15	270	465
EJ5500	125-300	17	500	1120

**EM** **Tweezers**  
 Pinzette  
 Pincette  
 Pinzeta



Part No.	l mm	g
EM1100	110	12
EM2000	200	30

**EK** **Pliers, diagonal cutting**  
 Seitenschneider  
 Pince coupante diagonale  
 Alicates de corte diagonal **DIN 5238**  
**ISO 5749**



Part No.	p mm	l mm	g
EK1550	9	155	170
EK1800	12	180	185

**EN** **Pliers, top cutting**  
 Vornschneider  
 Pince à tête coupante  
 Pinza de corte superior **DIN 5234**  
**ISO 6748**



Part No.	p mm	l mm	g
EN1850	12	185	315

EP

**Pliers, cutting**

Beißzange  
Tenaille  
Pinza cortadora

DIN 5241  
ISO 9243



Part No.	p mm	l mm	g
EP2000	20	200	488

ER

**Pliers, pipe**

Gasbrennerzange  
Pince à gaz  
Alicate para tubos gas

DIN 5247  
ISO 9243



Part No.	p mm	l mm	g
ER2500	13	250	618

ES

**Pliers, Swedish**

Eckrohrzange  
Clé serre-tube, type suédois  
Pinza sueca

DIN 5234 B



Part No.	a max inch	a max mm	p mm	l mm	g
ES3500	1	35	16	320	735
ES4400	1.1/2	45	22	440	1420
ES5600	2	55	25	560	2525

ET

**Adjustable pipe wrench**

Verstellbarer Rohrschlüssel  
Clé serre-tube  
Llave Ajustable para tubos

DIN 5244  
ISO 5746

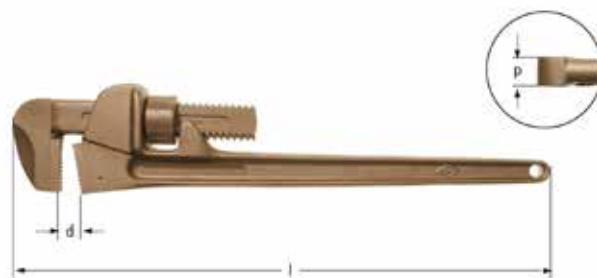
**BRONZE**

Part No.	d max inch	d max mm	p mm	l mm	"	g
ET0215	3/4	19	18	215	8	605
ET0280	1	25	20	280	10	930
ET0305	1.9/16	40	25	305	12	1480
ET0350	1.1/2	28	38	350	14	1630
ET0420	2	50	26	420	18	2180
ET0565	2.1/2	65	30	565	24	3810
ET0770	3.1/2	90	35	770	36	7220
ET1110	5	130	39	1100	48	10400

**ALUMINUM**

Part No.	d max inch	d max mm	p mm	l mm	g
ET1280A	1	25	20	280	615
ET1350A	1.1/2	38	23	350	955
ET1420A	2	50	26	420	1485
ET1565A	2.1/2	65	30	565	2480
ET1770A	3.1/2	90	35	770	4215
ET2110A	5	130	39	1100	8040

EU

**Chain pipe wrench**

Kettenrohrzange  
Serre-tube à chaîne  
Llave Encadenadora de Tubos



Part No.	d max inch	d max mm	p mm	l mm	g
EU0510	1.1/2	38	55	510	2650
EU0685	2.1/2	65	62	685	4500
EU0915	4	100	76	915	12710
EU1830	12	305	90	1830	15800

EV

**Pipe cutter**Rohrabschneider  
Coupe-tube  
Cortadora tubo

Part No.	d max inch	d max mm	p mm	l mm	g
EV2050	2	50	50	430	2500





FA>FV

HAMMERS, AXES

HÄMMER, AXT

MARTEAUX, HACHES

MARTILLOS, HACHAS





FA

**Axe, flat head**

Axt  
Hache d'abattage  
Hacha



Part No.	H g	a mm	b mm	l mm	g
FA0005	1500	125	200	920	2770
FA0006	2400	125	200	920	3630

FA

**Axe, pick head**

Feuerwehraxt  
Hache de pompier  
Hacha de Bombero

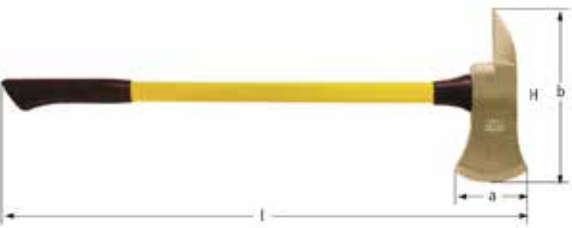

Part No.	H g	a mm	b mm	l mm	g
FA0015	1850	125	300	920	3040
FA0016	2950	125	300	920	4200

FB

**Hatchet**

Beil  
Hachette de charpentier  
Hachuela

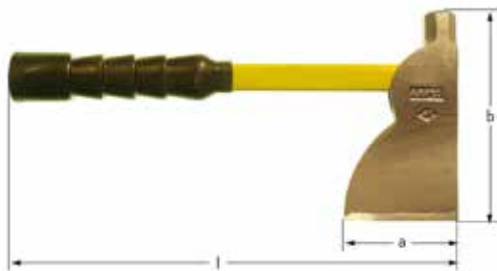

Part No.	a mm	b mm	l mm	g
FB0090	95	170	355	980

FC

**Hammer, cross peen engineer's**

Handhammer, amerikanische Form  
Massette anglaise  
Martillo de Ingeniero de Golpe Cruzado



Part No.	H lbs	H g	l mm	g
FC0040	1.5	680	355	970
FC0041	2.5	1135	380	1510
FC0042	3.5	1590	380	1950

FD

**Hammer, ball peen**

Schlosserhammer, amerikanische Form  
Marteau de mécanicien, type américain  
Martillo de Ingeniero



Part No.	H lbs	H g	l mm	g
FD1000	0.25	115	250	170
FD1001	0.75	340	350	585
FD1002	1	455	350	700
FD1003	1.5	680	360	895
FD1004	2	905	360	1170
FD1005	2.25	1020	360	1305
FD1006	2.75	1250	360	1410

FE

**Hammer, double face engineer's**

Handhammer, amerikanische Form  
Massette carrée  
Martillo de Doble Cabeza



Part No.	H lbs	H g	l mm	g
FE0014	1.75	800	355	1045
FE0015	2.25	1020	355	1280
FE0016	2.75	1250	380	1530
FE0017	3	1360	380	1680

FF

**Hammer, sledge German type**Fäustel  
Masse à pans  
Acotillo

DIN 6475



Part No.	H g	l mm	g
FF0100	1000	360	1200
FF0125	1250	380	1450
FF0150	1500	380	1750
FF0200	2000	400	2250
FF0250	2500	600	2800
FF0300	3000	600	3350
FF0400	4000	600	4400
FF0500	5000	800	5500
FF0600	6000	900	6600
FF0800	8000	900	8700
FF1000	10000	900	10800

FH

**Mallet**Schlägel  
Massette, forme baril  
Mazo

Part No.	H lbs	H g	l mm	g
FH0001	2	900	355	1110
FH0002	4	1820	380	1990
FH0003	6	2730	380	2870

FJ

**Hammer, double face machinist's**Maschinenhammer  
Marteau d'ajuteur  
Martillo de Maquinista

Part No.	H lbs	H g	l mm	g
FJ0044	0.25	115	255	170
FJ0045	1.5	680	360	895
FJ0046	1.75	800	360	920
FJ0047	2	910	360	1080

FG

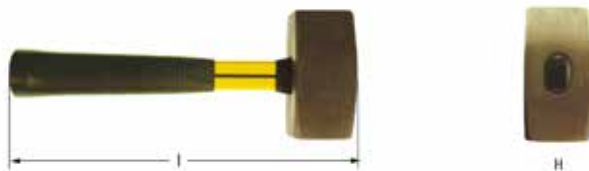
**Hammer, club**Fäustel, club-hammer  
Massette carrée  
Martillo de doble cabeza

Part No.	H lbs	H g	l mm	g
FG0321	2	910	255	1185
FG0323	4	1820	255	2020

FG

**Hammer, sledge**Fäustel, amerikanische Form  
Masse à pans  
Acotillo

Part No.	H lbs	H g	l mm	g
FG0068	2	900	255	1100
FG0069	3	1360	380	1570
FG0070	5	2270	840	3220
FG0071	7.5	3400	840	4300
FG0072	10	4540	840	5030
FG0073	15	6800	840	7300
FG0074	18	8170	840	8740
FG0075	22	9900	830	10900

FK

**Hammer, claw**Klauenhammer  
Marteau de charpentier  
Martillo con garra

Part No.	H lbs	H g	l mm	g
FK0019	0.75	340	360	645
FK0020	1	455	360	760
FK0021	1.25	570	360	955

FL

**Hammer, scaling**

Entrostungshammer  
 Marteau à piquer  
 Martillo burilador



Part No.	H lbs	H g	l mm	g
FL0060	1	455	355	680
FL0061	1.5	680	355	930
FL0062	3	1360	380	1550

FN

**Hammer, bricklayer's**

Maurerhammer  
 Marteau de maçon, type allemand  
 Martillo de albañil

DIN 5108



Part No.	H g	l mm	g
FN0600	600	290	710
FN0800	800	300	970

FM

**Hammer, cutoff**

Schrotmeißel  
 Marteau de burinage  
 Martillo de corte

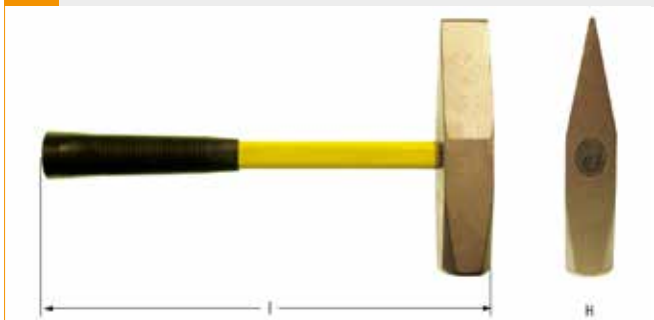

Part No.	H lbs	H g	l mm	g
FM0050	3	1360	380	1495
FM0051	5	2270	380	2400

FP

**Riveter**

Setzhammer  
 Marteau à riveter  
 Remachador



Part No.	H g	l mm	g
FP1500	1500	380	1700

FN

**Hammer, bricklayer's**

Maurerhammer  
 Marteau de maçon  
 Martillo de albañil



Part No.	H lbs	H g	l mm	g
FN0010	1.5	680	360	1030

FR

**Hammer, backing out tool**

Durchtreiber mit Stiel  
 Marteau à poinçon  
 Martillo de apoyo externo



Part No.	d mm	l mm	g
FR0008	8	330	500
FR0010	10	330	550
FR0012	12	350	800
FR0016	16	350	860

FS

**Hammer, cross peen, German type**

Schlosserhammer

Marteau, mécanicien

Martillo de Ingeniero de Golpe Cruzado

DIN 1041



Part No.	H g	l mm	g
FS0100	100	260	150
FS0150	150	280	220
FS0200	200	280	300
FS0300	300	300	400
FS0400	400	320	520
FS0500	500	320	650
FS0600	600	330	750
FS0700	700	350	900
FS0800	800	350	1000
FS1000	1000	360	1250
FS1250	1250	380	1550
FS1500	1500	380	1850
FS2000	2000	400	2400

FV

**Hammer, cross peen, heavy duty**

Vorschlaghammer

Masse, type allemand

Martillo de Golpe Cruzado

DIN 1042



Part No.	H g	l mm	g
FV0250	2500	600	2900
FV0300	3000	600	3600
FV0400	4000	600	4600
FV0500	5000	800	5700
FV0600	6000	800	6800
FV0800	8000	900	9000
FV1000	10000	900	11200
FV1500	15000	920	16500

FT

**Hammer, cross peen, German type, fiberglass handle**

Schlosserhammer, fiberglasgrif

Marteau mécanicien, manche en fibre de verre

Martillo de ingeniero, mango de fibra de vidrio



Part No.	H g	l mm	g
FT0200	200	250	300
FT0300	300	355	400
FT0500	500	355	650
FT0800	800	355	1000
FT1000	1000	355	1250

GF > GW

SCREWDRIVERS  
SCHRAUBENDREHER  
TOURNEVIS  
DESTORNILLADORS





GF

**Screwdriver, flat**

Schlitz-Schraubendreher  
Tournevis, lame plate  
Destornilladores, Hoja Cilindrica

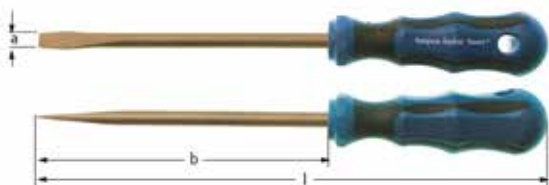

Part No.	a mm	b mm	l mm	g
GF0306	3	60	150	20
GF0315 *	3	150	240	60
GF0407	4	70	160	35
GF0412	4	120	210	45
GF0508	5	80	170	50
GF0510 *	5	100	190	60
GF0520 *	5	200	290	75
GF0605	6	50	150	60
GF0610	6	100	200	80
GF0615 *	6	150	250	85
GF0808	8	80	190	70
GF0815	8	150	260	130
GF1020	10	200	320	225
GF1030	10	300	420	305
GF1038	10	380	500	345

\* Electrician

GT

**Torx screwdrivers**

Sätze  
Tournevis Torx  
Juegos

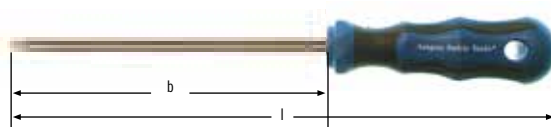

Part No.	TN No.	b mm	l mm	g
GT0005	5	60	150	40
GT0006	6	60	150	40
GT0007	7	60	150	40
GT0008	8	60	150	40
GT0009	9	60	150	40
GT0010	10	80	170	50
GT0015	15	80	180	70
GT0020	20	100	200	75
GT0025	25	100	200	75
GT0027	27	115	225	120
GT0030	30	115	225	122
GT0040	40	130	250	190
GT0045	45	130	250	195
GT0050	50	150	270	248
GT0055	55	150	270	257
GT0060	60	150	270	333

GK

**Screwdriver, Phillips**

Kreuzschlitz-Schraubendreher  
Tournevis Phillips  
Destornillador estrella



Part No.	PH No.	b mm	l mm	g
GK0006	0	60	150	25
GK1008	1	80	170	60
GK2010	2	100	200	85
GK3015	3	150	260	135
GK4020	4	200	320	230

GW

**Screwdriver, offset**

Winkelschraubendreher  
Tournevis coudé  
Destornillador acodado



Part No.	a mm	l mm	g
GW0412	4	120	25
GW0613	6	135	40
GW1014	10	140	60
GW1319	13	190	200

GS

**Sets**

Sätze  
Jeux  
Juegos

Part No.	Content	pcs	g
GS1001	8x80, 8x150, 10x200mm, PH No.2	4	625
GS1002	8x80, 8x150, 10x200mm, PH No.1, 2, 3	6	845
GS1003 *	3x150, 4x120, 5x200, 6x150mm	4	265

\* Electrician

HA > HK

PUNCHES  
DURCHTREIBER  
CHASSE-CLOUS  
PUNZONES



**HA** **Punch**  
Durchtreiber  
Chasse-clou standard  
Punzón DIN 6458



Part No.	a mm	d mm	l mm	g
HA0112	1	8	120	38
HA0212	2	8	120	40
HA0312	3	8	120	40
HA0412	4	8	120	40
HA0512	5	10	120	60
HA0612	6	10	120	65
HA0716	7	13	160	140
HA0816	8	13	160	140
HA0916	9	16	160	220
HA1016	10	16	160	220
HA1216	12	16	160	220
HA1416	14	16	160	220
HA1620	16	19	200	500
HA1820	18	19	200	500
HA2020	20	22	200	620

**HB** **Drift pin, straight type**  
Durchtreiber, konisch  
Chasse-clou  
Perno de dirección, tipo recto



Part No.	a mm	d mm	l mm	g
HB0020	6	13	150	100
HB0021	7	17	150	100
HB0022	8	21	205	175
HB0023	12	24	255	645
HB0024	13	29	255	865

**HB** **Punch, machinist's**  
Durchtreiber, konisch  
Chasse-clou, série lourde  
Punzón de mecánico



Part No.	a mm	d mm	l mm	g
HB0040	5	16	215	255
HB0041	10	19	230	420
HB0042	13	25	255	880

**HC** **Drift pin, barrel type**  
Durchtreiber, spindelförmig  
Broche fusiforme  
Perno de dirección, tipo barril



Part No.	a mm	d mm	l mm	g
HC0001	8	17	200	230
HC0002	8	21	200	360
HC0003	10	24	200	415
HC0004	13	27	200	630
HC0005	18	30	200	880
HC0006	22	33	200	1050

**HD** **Pin punch**  
Splinttreiber  
Chasse-goupilles  
Botador DIN 6450



Part No.	a mm	d mm	l mm	g
HD0111	1.5	8	110	50
HD0211	2	8	110	50
HD0311	3	8	110	50
HD0412	4	10	120	80
HD0513	5	10	130	90
HD0614	6	10	140	100
HD0815	8	13	150	140
HD1016	10	13	160	160
HD1318	13	16	180	340
HD1620	16	16	200	400

**HE**

**Pin punch**  
Splinttreiber  
Chasse-gouilles, série légère  
Botador



Part No.	a mm	d mm	l mm	g
HE0050	3	10	130	40
HE0051	6	14	150	120
HE0052	10	14	180	160
HE0053	13	18	200	290
HE0054	16	20	300	655

**HF**

**Center punch**  
Körner  
Pointeau  
Punzón de marcar



Part No.	d mm	l mm	g
HF1290	8	100	30
HF1291	10	115	45
HF1292	13	125	95
HF1293	16	150	175

**HG**

**Double-end scriber**  
Reissnadel  
Pointe à tracer double  
Rayador de doble extremo



Part No.	d mm	l mm	g
HG0225	4	225	45

**HH**

**Awl**  
Vorstecher  
Alène  
Lesna



Part No.	d mm	l mm	g
HH0185	4	185	65

**HJ**

**Pin, straight**  
Zugdorn  
Goupille droite  
Perno recto

DIN 6459



Part No.	d mm	l mm	g
HJ0085	8	85	40
HJ0090	10	90	50
HJ0100	13	100	70
HJ0110	16	110	100
HJ0140	19	140	180
HJ0160	21	160	270
HJ0200	25	200	450
HJ0240	29	240	630

**HK**

**Pin, offset**  
Winkeldorn  
Goupille coudée  
Perno acodado



Part No.	d mm	l1 mm	l2 mm	g
HK1600	16	150	450	930
HK1900	19	150	450	1300
HK2500	25	150	450	2000
HK2900	29	150	450	2300
HK3000	30	150	450	3300

JA>JT

SCRAPERS, KNIVES

SCHABER, MESSER

GRATTOIRS, COUTEAUX

RASPADORES, CORTADORES





JA

**Scraper, flat**  
Flachschaber  
Grattoir de mécanicien  
Raspador plano

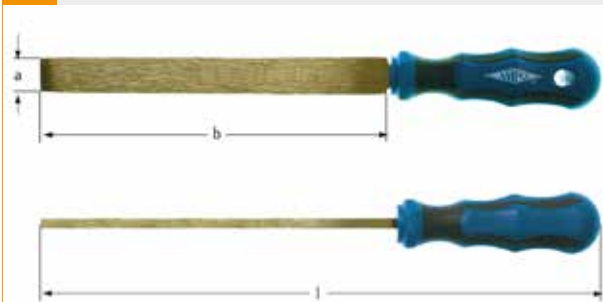

Part No.	a mm	b mm	l mm	g
JA0200	20	200	310	210

JB

**Scraper, triangular**  
Dreikantschaber  
Grattoir triangulaire  
Raspador triangular



Part No.	b mm	l mm	g
JB0200	200	310	185

JC

**Knife, common**  
Messer  
Couteau, forme droite  
Cuchillo común



Part No.	b mm	l mm	g
JC0001	80	175	30

JC

**Knife, common with antistatic handle**

Part No.	b mm	l mm	g
JC0002	110	220	63

JC

**Knife, common**  
Messer  
Couteau, forme droite  
Cuchillo común



Part No.	b mm	l mm	g
JC0005	145	260	80

JC

**Knife, linoleum**  
Linoleum-Messer  
Couteau à linoleum  
Cuchillo linoleo



Part No.	a mm	b mm	l mm	g
JC0040	50	60	190	80

JC

**Knife, utility**  
Universalmesser  
Couteau de cordonnier  
Cuchillo zapatero



Part No.	a mm	b mm	l mm	g
JC0010	25	105	220	75

JD

**Knife, putty, stiff blade**  
Spachtel, starres Blatt  
Couteau de vitrier, lame rigide  
Espátula de hoja rígida



Part No.	a mm	b mm	l mm	g
JD0020	20	90	190	65
JD0030	30	90	195	75
JD0050	50	105	205	120
JD0090	90	115	220	165

JD

**Knife, putty, flexible blade**  
Spachtel, biegsames Blatt  
Couteau de vitrier, lame souple  
Espátula de Hoja Flexible



Part No.	a mm	b mm	l mm	g
JD1090	90	115	220	115

JD

**Knife, putty, stiff blade, anti-static handle**

Spachtel, starres Blatt, mit antistatischem Griff  
 Couteau de vitrier, lame rigide, à poignée anti-statique  
 Espátula de hoja rígida, mango anti-estático



Part No.	a mm	b mm	l mm	g
JD1025	25	140	250	100
JD1050	50	130	240	125
JD1075	75	130	240	150

JD

**Knife, putty, flexible blade, anti-static handle**

Spachtel, biegsames Blatt, mit antistatischem Griff  
 Grattoir à mastic, lame souple, à poignée anti-statique  
 Espátula de hoja flexible, mango anti-estático



Part No.	a mm	b mm	l mm	g
JD2075	75	130	240	125

JE

**Spatula**

Spachtelmesser  
 Spatule  
 Espátula



Part No.	a mm	b mm	l mm	g
JE0025B	25	150	260	85
JE0040B	40	230	350	145
JE0050B	50	355	490	275

JE

**Spatula, with anti-static handle**

Spachtelmesser mit antistatischem Griff  
 Spatule, à poignée anti-statique  
 Espátula, mango anti-estático



Part No.	a mm	b mm	l mm	g
JE1675	16	75	210	180
JE2515	25	150	270	100

JF

**Scraper, deck**

Winkelschaber  
 Grattoir coudé  
 Raspador elevado



Part No.	a mm	l mm	g
JF0200	22	200	210
JF0300	55	300	570

JF

**Scraper, deck**

Winkelschaber mit Griff  
 Grattoir coudé, à poignée  
 Raspador elevado



Part No.	a mm	l mm	g
JF0380	38	380	780

**JG**

**Scraper, without handle**

Schaber, ohne Stiel  
Grattoir, sans manche  
Raspador, sin mango

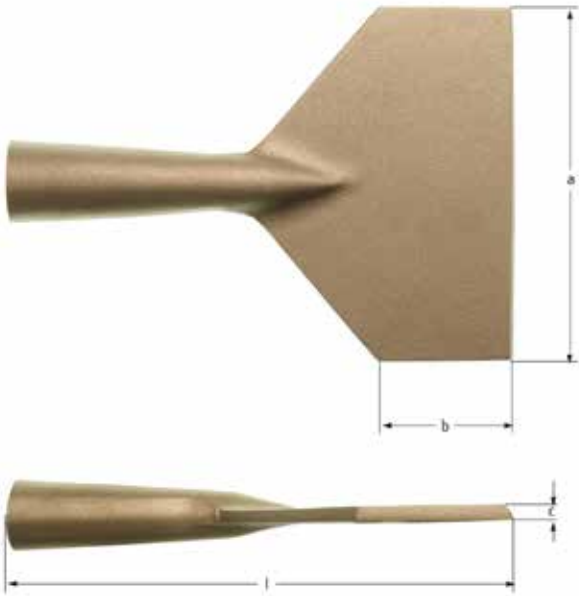

Part No.	a mm	b mm	c mm	l mm	g
JG0075	75	65	6	220	605
JG0100	100	65	6	220	780
JG0125	125	65	6	220	820
JG0150	150	65	6	220	900

**Handle**

Stiel  
Manche  
Mango

Part No.	l mm
WHF	1500

**JH**

**Scraper, spray booth**

Spritzkabinenschaber  
Grattoir pour cabine de peinture  
Raspador para cabina de pintar



Part No.	a mm	l mm	g
JH0075	75	235	345

**JK**

**Scraper, hand style**

Schaber mit Stiel  
Grattoir d'aire, emmanché  
Raspador estilo mano



Part No.	a mm	b mm	l mm	g
JK0095	95	95	480	640

**JL**

**Scraper, ship**

Plattenschaber  
Grattoir de peintre, forme trapèze  
Raspador de viajado



Part No.	a mm	b mm	l mm	g
JL0100	100	75	415	635
JL0101	100	75	-	195

**JM**

**Scraper, pick and scaler**

Reinigungswerkzeug  
Pic à grattoir  
Raspador pico



Part No.	a mm	l mm	g
JM0075	75	450	1100

JP

**Scraper, rust, with handle**

Roststecher mit Stiel  
Grattoir antirouille, emmanché  
Raspador de oxido



Part No.	a mm	b mm	l mm	g
JP0600	75	200	600	560
JP0800	75	200	800	680
JP1000	75	200	1000	800
JP1200	75	200	1200	920

JS

**Thread cleaning pick**

Gewindereinigungsstift  
Pointe pour nettoyer les filetages  
Pico Removedor de filamentos



Part No.	a mm	l mm	g
JS3003	6	300	66
JS3010	10	300	145
JS3013	13	300	255

JR

**Knife, gasket**

Flanschmesser  
Couteau à joints  
Cuchillo para empaquetaduras

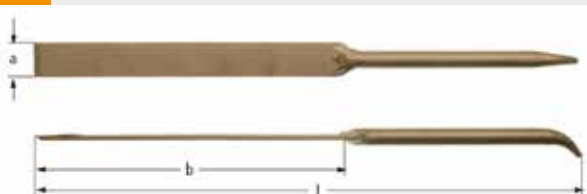

Part No.	a mm	b mm	l mm	g
JR0400	25	220	400	300

JT

**Mop holder**

Wischtuchhalter  
Porte-faubert  
Sujetador de la mopa

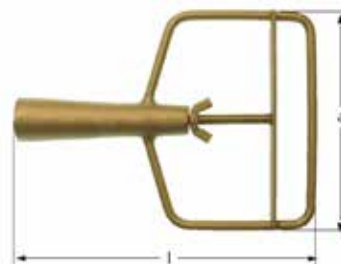

Part No.	a mm	l mm	g
JT0170	170	225	670

JR

**Knife, gasket**

Flanschmesser  
Couteau à joints  
Cuchillo para empaquetaduras

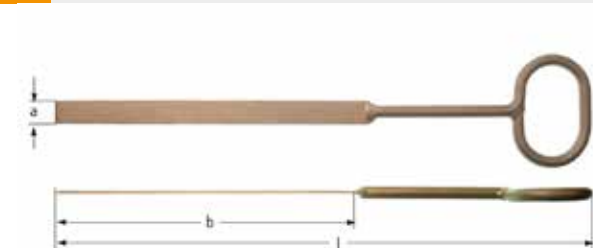

Part No.	a mm	b mm	l mm	g
JR0690	30	400	690	1200
JR1240	40	800	1240	2000

**KB>KP**

BRUSHES  
BÜRSTE  
BROSSES  
CEPILLOS





KA

**Drive arbor, wheel brush**

Aufnahme für vorstehend Rundbürsten  
Tige de fixation pour brosses circulaires  
Vastago de fijación para cepillo de disco



Part No.	d1 mm	d2 mm	l mm	g
KA0125A	12.5	6.4	22	46

KB

**Broom, round wire**

Besen, Runddraht glatt  
Balai de rue, fil rond  
Escoba, de alambre redondo



Part No.	a mm	b mm	l mm	Rows	g
KB0001	75	55	305	6x25	1500

KC

**Cup brush, crimped wire**

Topfbürste, Runddraht gewellt  
Brosse à boisseau, circulaire, fil ondulé  
Cepillo de copa, circular, de alambra redondo ondulado

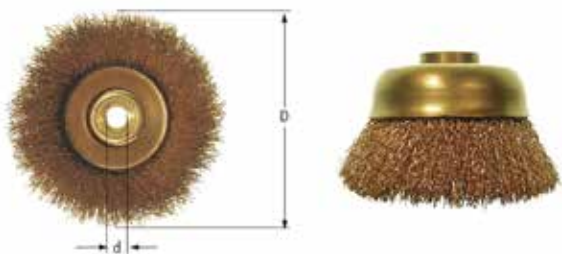

Part No.	D mm	d UNC-11	RPM max	g
KC0076	76	5/8	12500	365
KC1102	102	5/8	8500	500
KC1153	153	5/8	4500	1040
KC0065	65	M14	12500	230
KC0102	102	M14	8500	500
KC0153	153	M14	4500	1040

KC

**Cup brush, knot wire**

Topfbürste, Runddraht gezopft  
Brosse à boisseau, circulaire, fil en tresses  
Cepillo de copa, circular de alambre redondo rancio



Part No.	D mm	d UNC-11	RPM max	g
KC2076	76	5/8	12500	300
KC2102	102	5/8	8500	560
KC2153	153	5/8	6000	1540
KC2202	102	M14	8500	560
KC2265	65	M14	12500	220
KC2276	76	M14	12500	300

KH

**Brush, curved handle**

Handdrahtbürste, Runddraht glatt  
Brosse à manche, fil rond  
Cepillo, de alambre redondo



Part No.	a mm	b mm	l mm	Rows	g
KH0002	45	30	350	3x19	165
KH0003	45	30	350	4x19	195

KH

**Brush, curved back**

Kastenbürste, gebogen, Runddraht glatt  
Brosse à dos courbé, dure, fil rond  
Cepillo de alambre redondo



Part No.	a mm	b mm	l mm	Rows	g
KH0005	45	30	185	6x19	280

**KH****Brush, flat back**

Kastenbürste, Runddraht glatt  
Brosse à dos plat, dure, fil rond  
Cepillo de alambre redondo



Part No.	a mm	b mm	l mm	Rows	g
KH0004	65	40	180	6x19	300

**KP****End brush**

Pinselfürste  
Brosse pinceau  
Pincel plano



Part No.	D mm	d mm	l mm	RPM Max	g
KP0026	26	6.4	25	20000	135
KP1026	26	6.4	25	20000	135

**KH****Brush, shoe handle**

Handdrahtbürste, Runddraht glatt  
Brosse à manche cintré, fil rond  
Cepillo, de alambre redondo



Part No.	a mm	b mm	l mm	Rows	g
KH0001	45	30	285	4x16	140

**KR****Wheel brush, knot wire**

Rundbürste, Runddraht gezopft  
Brosse circulaire, fil en tresses  
Cepillo, circular de alambre redondo rancio

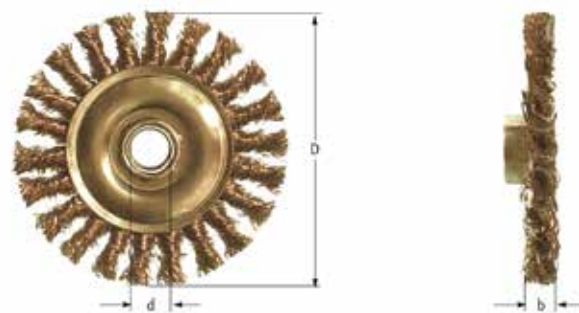

Part No.	D mm	b mm	d UNC-11	RPM Max	g
KR1020	102	9	5/8	20000	225
KR1530	153	13	5/8	9000	590

**KK****Brush, spark-plug cleaning**

Zündkerzenbürste, Runddraht glatt  
Brosse pour bougies  
Cepillo para bujias



Part No.	a mm	b mm	l mm	Rows	g
KK0001	22	13	195	3x7	18

**KR****Wheel brush, crimped wire**

Rundbürste, Runddraht gewellt  
Brosse circulaire, fil ondulé  
Cepillo circular, de alambre redondo ondulado

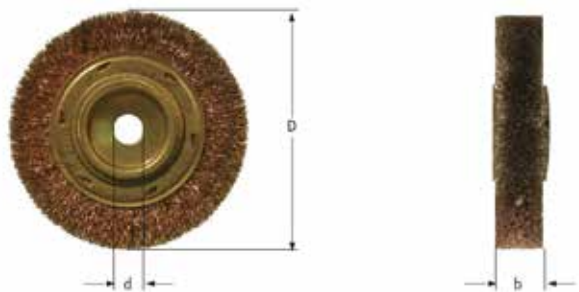

Part No.	D mm	b mm	d mm	RPM Max	g
KR0050	50	7	13	20000	45
KR0076	76	10	13	20000	70
KR0102	102	19	10	6000	365
KR1102	102	19	13	6000	365
KR2102	102	19	16	6000	365
KR0153	153	26	13	4500	725
KR1153	153	26	16	4500	725
KR2153	153	26	19	4500	725
KR3153	153	26	26	4500	725
KR4153	153	26	32	4500	725

KS

**Scrubbing broom, round wire**

Schrubber, Runddraht glatt  
Brosse à décaper, fil rond  
Cepillo de lavado de alambre redondo



Part No.	a mm	b mm	l mm	Rows	g
KS0001	60	40	220	6x17	480

KT

**Brush, tube**

Zylinderbürste, Draht gewellt  
Goupillon  
Cepillo de tubo



Part No.	a mm	b mm	l mm	g
KT0001	20	100	340	42





MA>MN

CHISELS, WEDGES  
MEISSEL, KEIL  
BURINS, COINS  
CINCELES, CUÑAS



MA

**Chisel, hand**

Flachmeißel  
Burin  
Cinzel de mano



Part No.	a mm	s mm	l mm	g
MA0130	8	6	130	35
MA0145	10	10	145	75
MA0155	14	12	155	145
MA1155	17	17	155	240
MA0200	20	19	200	400
MA0220	23	23	220	580
MA0225	20	20	225	475
MA0230	17	17	230	380
MA1230	27	24	230	740
MA0270	50	32	270	1645
MA0305	14	14	305	300
MA1305	22	19	305	655
MA0370	19	14	370	420
MA0450	26	26	450	1645
MA0760	24	24	760	2610

MB

**Chisel, hand, oval**

Flachmeißel, oval  
Burin, oval  
Cinzel de mano, oval

DIN 6453



Part No.	a mm	s mm	l mm	g
MB0150	18	17	150	170
MB0200	24	23	200	160
MB0250	25	26	250	435
MB0300	26	26	300	545

MC

**Chisel, cape**

Kreuzmeißel  
Bédane de mécanicien  
Cortahierro de ranurar



Part No.	a mm	s mm	l mm	g
MC0150	11	16	150	230
MC0205	13	20	205	410
MC0235	17	22	235	630
MC0300	16	25	300	1050
MC0400	19	29	400	1800

MD

**Chisel, groove**

Nutenmeißel  
Bédane  
Cinzel de ranurar



Part No.	a mm	s mm	l mm	g
MD0200	10	19	200	430
MD0225	13	22	225	670

ME

**Chisel, diamond point**

Diamantspitzmeißel  
Burin à pointe, forme diamant  
Cinzel punta de diamante



Part No.	a mm	s mm	l mm	g
ME0205	13	20	205	435
ME0310	19	23	310	915



MF

**Chisel, concrete**

Betonmeißel  
Burin à béton  
Cinzel para hormigón



Part No.	a mm	s mm	l mm	g
MF0380	45	33	380	3040

MH

**Pneumatic chisel, flat end**

Preßluftflachmeißel  
Burin pour marteau pneumatique  
Cinzel neumático



Part No.	a mm	l1 mm	l2 mm	d mm	s mm	g
MH0065	65	305	153	43	28.6	2630
MH0075	75	305	153	43	28.6	2690

MG

**Pneumatic chisel, bull point**

Preßluftspitzmeißel  
Fleuret pour marteau pneumatique  
Rompedor



Part No.	s mm	l mm	g
MG0470	25.4	470	1820

MH

**Pneumatic chisel, spade end**

Preßluftspatenmeißel  
Tranche pour marteau pneumatique  
Pala neumática de arcilla



Part No.	a mm	l1 mm	l2 mm	d mm	s mm	g
MH0115	115	410	82	40	22	4150

MG

**Pneumatic chisel, bull point**

Preßluftspitzmeißel  
Fleuret pour marteau  
pneumatique  
Rompedor

DIN 20376



Part No.	l1 mm	l2 mm	d1 mm	d2 mm	g
MG0250	250	75	25	42	1140
MG0350	350	75	25	42	1600
MG0450	450	75	25	42	2050

MJ

**Pneumatic chisel, flat end, with collar**

Preßluftflachmeißel  
Burin pour marteau pneumatique  
Cinzel neumático



Part No.	a mm	l1 mm	l2 mm	d1 mm	d2 mm	g
MJ0032	32	110	60	17	31.5	140
MJ0040	40	130	60	17	31.5	420
MJ0046	46	140	60	17	31.5	500
MJ0063	63	150	60	17	31.5	610

MG

**Pneumatic chisel, bull point**

Preßluftspitzmeißel  
Fleuret pour marteau pneumatique  
Rompedor



Part No.	l1 mm	l2 mm	d mm	s mm	g
MG0375	375	153	43	28.5	2710
MG0400	400	153	43	31.7	3530

MK

**Pneumatic chisel, scaling**

PreBluftschaiber

Burin de détartrage pour marteau pneumatique

Cinzel burilador neumático



Part No.	a mm	l1 mm	l2 mm	d mm	g
MK0038	38	120	70	17	415
MK0044	44	130	70	17	510
MK0063	63	150	70	17	595

MM

**Caulking tool, concave**

Stemmwerkzeug, gewölbt

Matoir

Herramienta de rematar, cóncave

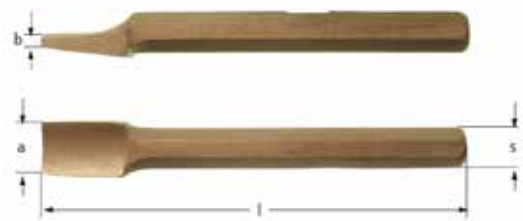

Part No.	a mm	b mm	s mm	l mm	g
MM0027	27	5	19	205	430

ML

**Pneumatic chisel, scaling**

PreBluftschaiber

Burin de détartrage, pour marteau pneumatique

Cinzel burilador neumático

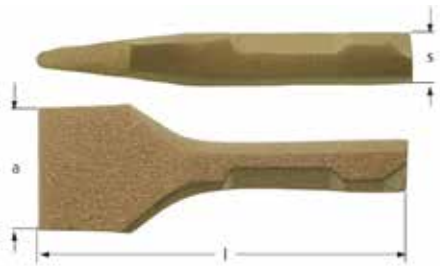

Part No.	a mm	s mm	l mm	g
ML0016	18	13	125	70
ML0030	24	13	90	115
ML0050	25	13	130	165
ML1050	26	13	200	330

MM

**Caulking tool**

Stemmwerkzeug

Matoir

Herramienta de rematar



Part No.	a mm	b mm	s mm	l mm	g
MM0015	15	2	12	260	225
MM0033	33	3	19	230	460

MM

**Caulking tool**

Stemmwerkzeug

Matoir

Herramienta de rematar



Part No.	a mm	b mm	s mm	l mm	g
MM0022	22	10	22	220	680

MM

**Caulking tool, flat edge, offset**

Stemmwerkzeug, Kante stumpf, gekröpft

Matoir

Herramienta de rematar



Part No.	a mm	b mm	s mm	l mm	g
MM3025	25	6	19	200	440

MM

**Caulking tool, half-round edge, offset**

Stemmwerkzeug, Kante rund, gekröpft  
Matoir  
Herramienta de rematar

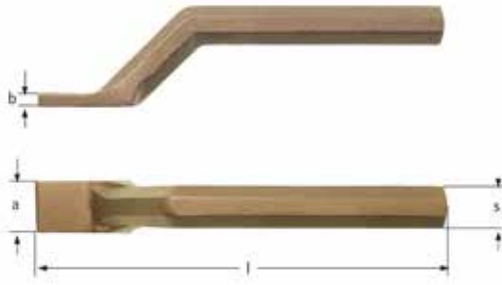

Part No.	a mm	b mm	s mm	l mm	g
MM3125	25	6	19	200	440

MM

**Caulking tool, half-round edge, straight**

Stemmwerkzeug, Kante rund, gerade  
Matoir  
Herramienta de rematar



Part No.	a mm	b mm	s mm	l mm	g
MM4125	25	6	19	200	400

MN

**Yarning tool**

Strickwerkzeug  
Matoir à cordes  
Herramienta de hilado



Part No.	a mm	b mm	s mm	l mm	g
MN0220	20	2	18	250	400
MN0420	20	4	18	250	430
MN0620	20	6	18	250	470
MN0820	20	8	18	250	500
MN1020	20	10	18	250	560

MP

**Wedge, flange**

Flanschkeil  
Coin, casse joint  
Cuña de Pestaña



Part No.	a mm	b mm	l mm	g
MP1501	15	6	80	50
MP1902	19	13	105	100
MP2503	25	13	150	200
MP3205	32	13	180	300
MP3804	38	19	150	400
MP3808	38	25	200	800
MP3807	38	41	200	1300
MP5012	50	10	90	200
MP5011	50	10	180	400
MP5006	50	19	180	730
MP5009	50	19	200	805
MP5010	50	32	215	1400

MP

**Wedge, stone**

Steinkeil  
Coin à pierre  
Cuña de piedra

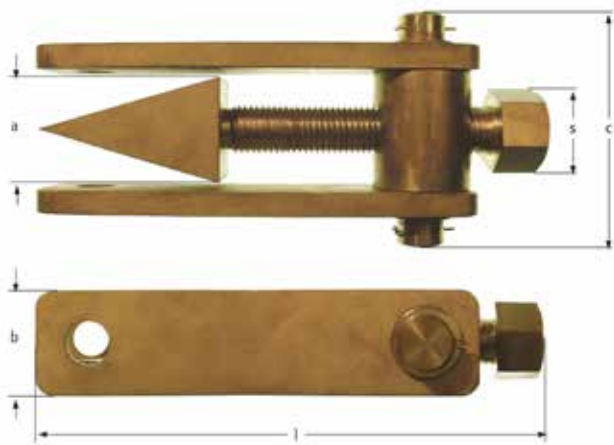

Part No.	a mm	l mm	g
MP0120	44	120	1120
MP0150	45	150	1475
MP0190	47	190	2015
MP0240	50	240	2800

**MR** Flange spreaderFlanschlöser  
Décolleur  
Veleta difusora

Part No.	a mm	b mm	c mm	s mm	l mm	g
MR6060	60	60	140	46	305	7200

**MS** Bar, pinchBrechstange  
Pince à talon  
Barra pie de cabra

Part No.	a mm	l mm	g
MS0460	25	460	1050
MS0760	30	760	2300
MS0910	38	910	3550

**MS** Bar, crowHebestange  
Pince à levier  
Barra pata de gallo

Part No.	a mm	l mm	g
MS1525	28	1525	8500
MS1730	32	1730	11000

**MT** Bar, wreckingNageleisen mit klaue  
Pince à décoffrer  
Barra de demolición

Part No.	a mm	b mm	l mm	g
MT0460	28	16	460	920
MT0610	33	19	610	1600
MT0760	39	22	760	2800
MT0920	43	22	920	3300

**MW** Spike, marlinErdungsspieß  
Epissoir  
Pica de marlin

Part No.	l mm	g
MW0406	406	916

NA>NT

UTILITY TOOLS  
DIENSTPROGRAMME  
OUTILS UTILITAIRES  
UTILIDADES HERRAMIENTAS





NA

**Railroad adze**

Platthacke  
Houe  
Azuela de ferrocarril

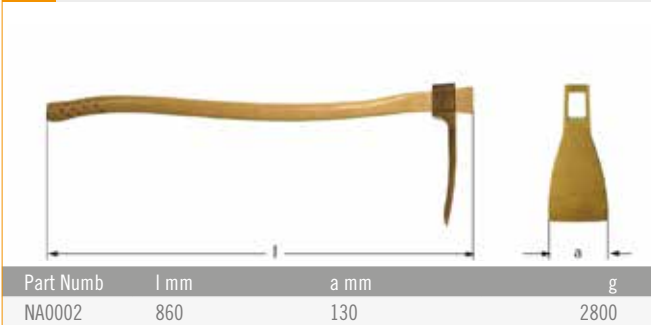

NF

**Garden fork**

Spatengabel  
Fourche bêche  
Horquilla de jardín

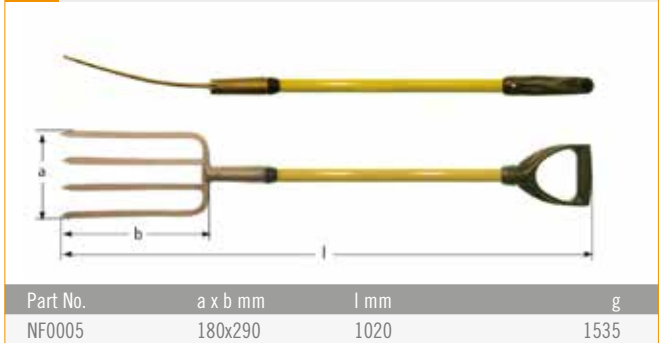

NB

**Mattock**

Breithacke  
Pioche à défricher  
Piqueta

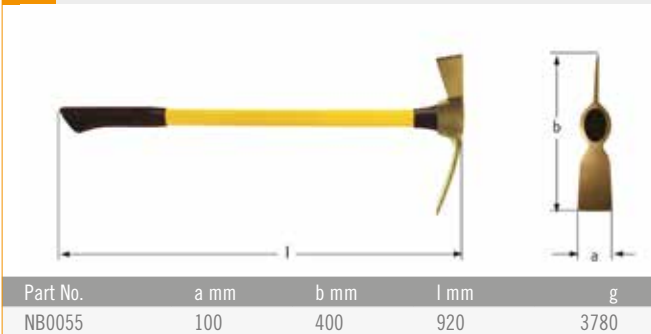

NF

**Manure fork**

Dunggabel  
Fourche à fumure  
Horquilla para abono

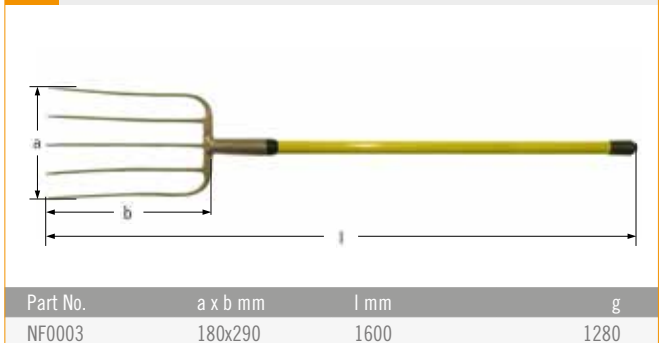

ND

**Edging spade with D-handle**

Spaten mit D-stiel  
Bêche, manche à poignée  
Azada de borde

DIN 20127



NF

**Hay fork**

Heugabel  
Fourche à foin  
Horquilla para heno

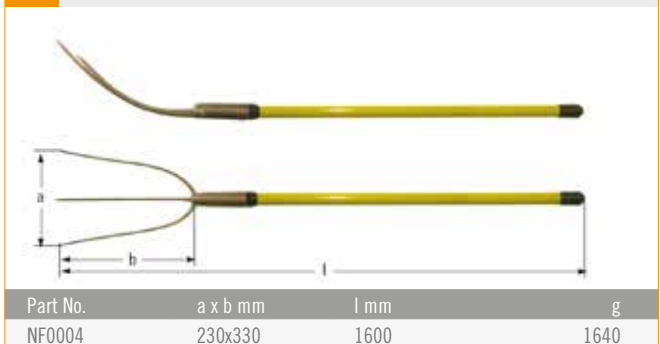

**NF**
**Guncotton fork, with handle**

Gabel für Schießbaumwolle, mit Stiel  
Fourche pour Fulmicoton, avec manche  
Horquilla para algodón, con mango



Part No.	a x b mm	l mm	g
NF0001	90x140	200	600
NF0011	150x250	370	1305

**NH**
**Garden hoe**

Gartenhaue  
Houe à manche long  
Azadón de jardín



Part No.	a mm	l mm	g
NH0100	150	1600	1505
NH0101	200	1600	1740
NH0102	250	1600	2050
NH0103	290	1600	2170

**NG**
**Miner's pick**

Grubenpickel  
Pic de mineur  
Pico de minero



Part No.	H mm	b mm	l mm	g
NG2100	2100	406	920	3310

**NK**
**Railroad pick**

Kreuzhacke  
Pioche de terrassier  
Pico de ferrocarril

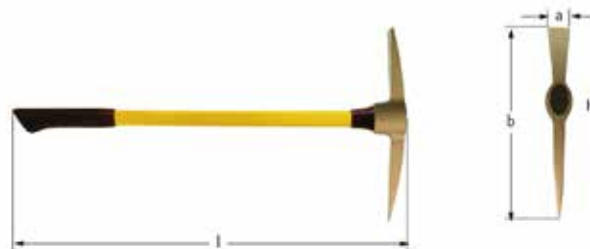

Part No.	H mm	a mm	b mm	l mm	g
NK2040	2040	25	535	920	3270
NK3040	3040	32	635	920	4210
NK4700	4700	38	700	920	6050

With wooden handle DIN 20123

Part No.	H mm	a mm	b mm	l mm	g
NK1500	1500	50	400	900	2050
NK2500	2500	50	500	950	3300
NK3000	3000	55	550	950	3900
NK3500	3500	55	600	950	4500
NK4500	4500	60	680	950	5500

**NH**
**Planter's hoe**

Haue  
Houe  
Azadón de plantación

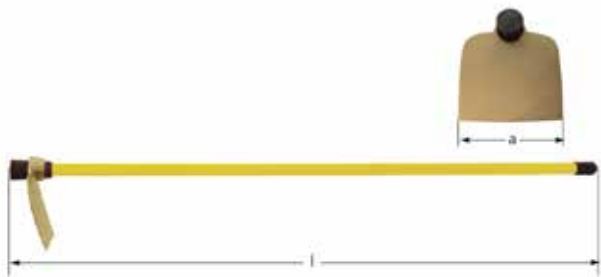

Part No.	a mm	l mm	g
NH0110	200	1570	1475

NM

**Trowel, bricklayer's**

Maurerkelle  
Truelle à joints  
Palustre para ladrillos



Part No.	a x b mm	l mm	g
NM1321	130x215	335	475
NM1428	140x280	360	615

NR

**Rake**

Rechen  
Râteau  
Rastrillo

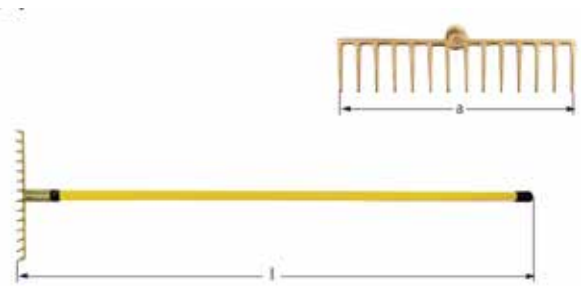

Part No.	a mm	l mm	g
NR0010	360	1600	1530

NN

**Dust pan**

Handschaufel  
Pelle à poussière  
Recogedor

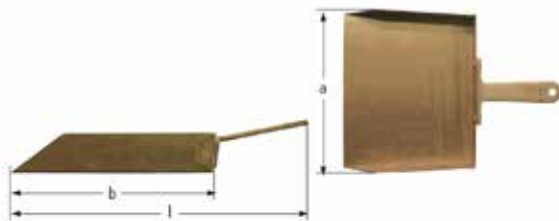

Part No.	a x b mm	l mm	g
NN0049	100x200	320	515
NN0050	225x190	310	785

NS

**Shovel, round point**

Schaufel, frankfurter form  
Pelle de terrassier, manche droit  
Pala de punta redonda

DIN 20121



Part No.	a x b mm	l mm	g
NS8100	230 x 280	1500	2230

NP

**Hand pick**

Handpickel  
Pic à main  
Pico de mano



Part No.	b mm	l mm	g
NP0096	230	370	990

NS

**Shovel, round point**

Schaufel, frankfurter form  
Pelle de terrassier, manche à poignée  
Pala de punta redonda

DIN 20121

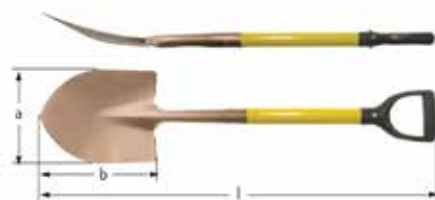

Part No.	a x b mm	l mm	g
NS8300	230 x 280	980	1990

**NS**
**Shovel, square edge**

 Randschaufel  
 Pelle à boue, manche à poignée  
 Pala de punta cuadrada

DIN 20123



Part No.	a x b mm	l mm	g
NS8200	230 x 280	1500	2250

**NS**
**Shovel, scoop**

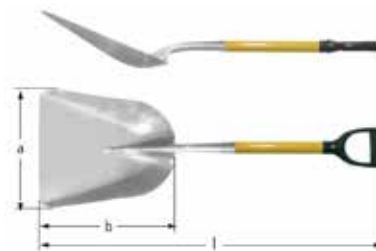
 Ballastschaufel  
 Pelle creuse, manche à poignée  
 Pala cuchara

Part No.	a x b mm	l mm	g
NS8000	330 x 430	1150	2750

**NS**
**Shovel, square edge**

 Randschaufel  
 Pelle à boue, manche droit  
 Pala de punta cuadrada

DIN 20123



Part No.	a x b mm	l mm	g
NS8400	230 x 280	980	2155

**NT**
**Edging spade with T-handle**

 Spaten mit T-stiel  
 Bêche, manche en T  
 Azada de borde

DIN 20127



Part No.	a x b mm	l mm	g
NT1000	185x280	1155	1200

**NS**
**Shovel, scoop**

 Ballastschaufel  
 Pelle creuse, manche droit  
 Pala cuchara

Part No.	a x b mm	l mm	g
NS7900	330 x 430	1700	2890

**NZ**
**Sugar scoop**

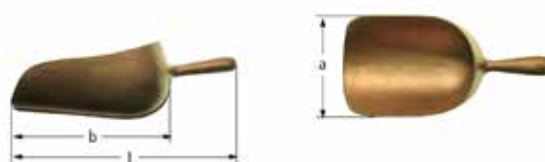
 Schöpfschaufel  
 Pelle pour granules et liquides  
 Cuchara recogedora de azúcar

Part No.	a x b mm	l mm	g
NZ0043	75x130	200	505
NZ0044	120x200	300	1135
NZ0045	140x240	350	1745

LF>PV

MISCELLANEOUS  
SONSTIGES  
DIVERS  
DIVERSO





LF

**Hand file**

Flachfeile  
Lime plate  
Lima de mano

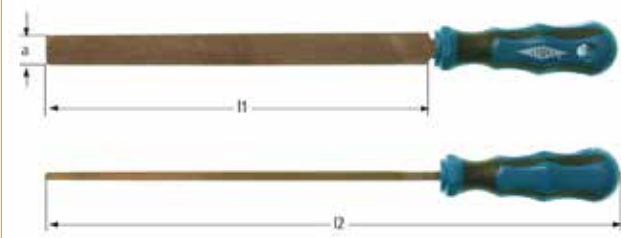

Part No.	a mm	l1 mm	l2 mm	g
LF2501*	20	250	360	275
LF2503**	20	250	360	275

LS

**Hack saw frame**

Bügelsäge  
Monture de scie à métaux  
Marco para sierra de corte

DIN 6473



Part No.	a mm	l1 mm	l2 mm	g
LS0300	115	300	540	860

LH

**Half round file**

Halbrundfeile  
Lime demi-ronde  
Lima de media circunferencia



Part No.	a mm	l1 mm	l2 mm	g
LH2501*	24	250	360	305
LH2503**	24	250	360	305

LS

**Blade, hack saw**

Sägeblatt  
Lame de scie à métaux  
Hoja de sierra de corte



Part No.	b mm	l mm	teeth inch	g
LS0310	14	310	24	20

LR

**Round file**

Rundfeile  
Lime ronde  
Lima redonda



Part No.	a mm	l1 mm	l2 mm	g
LR2501*	10	250	360	218
LR2503**	10	250	360	218

LS

**Hand saw (6 teeth/inch)**

Handsäge (6 Zähne/Zoll)  
Scie égoïne (6 dents/pouce)  
Serrucho de mano (6 dientes/pulgada)

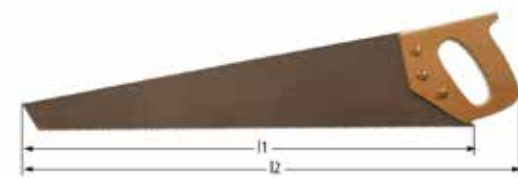

Part No.	l1 mm	l2 mm	g
LS0500	500	630	770

\* Bastard ; Hieb 1 ; Batârde ; Aspero  
\*\* Smooth ; Hieb 3 ; Douce ; Suave

PB

**Bucket**Eimer  
Seau  
Balde

Part No.	d x h mm	V l	g
PB1000	275x290	15	1450

PF

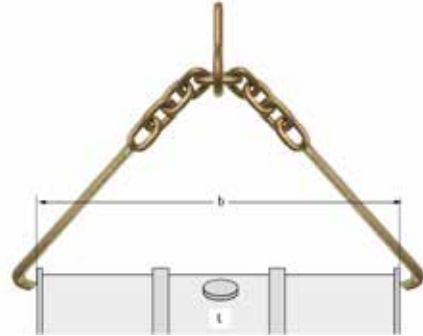
**Barrel hook, chain, adjustable**Fassheber, verstellbar über kette  
Crochet à fût, réglable  
Ganchos para barril, ajustable

Part No.	b Max kg	L Max mm	g
PF0710	1060	700	4545

PE

**Fireman's hook**Einreibhaken  
Crochet de pompier  
Gancho de bombero

DIN 14851



Part No.	a mm	l mm	g
PE0380	176	380	1800

PK

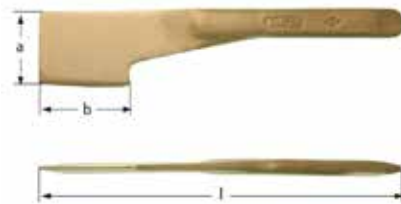
**Carbide drum opener**Karbiddrommelöffner  
Ouvre tonneau à carbure  
Abridor de toneles de carburo

Part No.	a x b mm	l mm	g
PK0305	60x75	305	750

PF

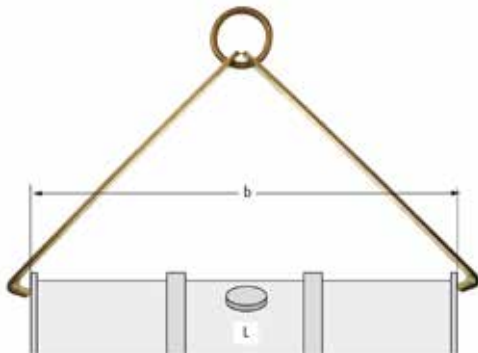
**Barrel hook, fixed**Fassheber  
Crochet à fût, fixe  
Ganchos para barril, fijado

Part No.	b Max kg	L Max mm	g
PF0715	1060	700	2430

PP

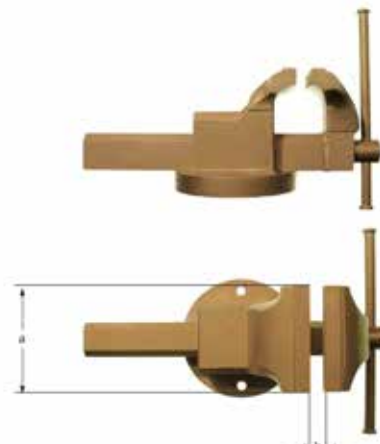
**Parallel vice**Parallel-schraubstock  
Étau  
Prensa paralela

Part No.	a mm	b Max mm	g
PP0135	130	170	17000

PP

**Grounding clamp**

Polschraubzwinde  
Serre-joint  
Prensa para toma



Part No.	a mm	b mm	l mm	g
PP0105	105	75	230	800

PS

**Clamp, bar**

Schraubzwinde mit Knebel  
Serre-joint, à manche  
Prensa, con mango

DIN 6413

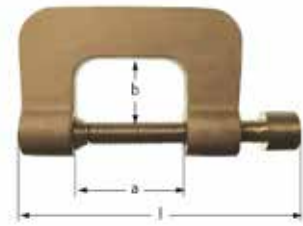

Part No.	a mm	b mm	l mm	g	PN Bar	d x l mm
PS0100	100	70	265	5000	PS1015A	10x150
PS0125	125	80	300	6250	PS1015A	10x150
PS0150	150	100	335	7500	PS1220A	13x200
PS0200	200	120	395	10000	PS1220A	13x200
PS0250	250	150	475	13750	PS1525A	16x250
PS0300	300	175	525	17500	PS1525A	16x250
PS0400	400	200	645	25000	PS1930A	20x300

PS

**Clamp**

Schraubzwinde  
Presse serre-joint  
Prensa

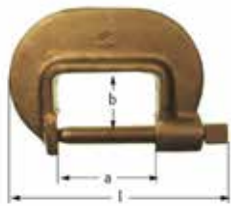

Part No.	a mm	b mm	l mm	g
PS0019	19	19	79	175
PS0115	115	75	290	4445
PS0165	165	90	370	9244

PV

**Crate opener**

Verschlagöffner  
Ouvre-caisses  
Abre cajas



Part No.	a mm	l mm	g
PV0230	70	230	420

PS

**Bar, clamp**

Knebel  
Manche, pour serre-joint  
Barra, para prensa



Part No.	d mm	l mm	g
PS1015	10	150	95
PS1220	13	200	180
PS1525	16	250	400
PS1930	20	300	650

RE>RT

SPECIAL KITS  
SPEZIELLE KITS  
KITS SPÉCIAUX  
KITS ESPECIALES



<b>RE</b>		
<b>Electrician's tool set</b>		
Elektriker - Werkzeugsatz		
Jeu d'outils d'électriciens		
Juego de herramientas electricista		
Part No.	Parts	g
RE1000	20	2800
Content	Dimension	Part No.
Round Nose Pliers	160 mm	EG1550B
Flat Nose Pliers	160 mm	EF1600B
Diagonal Sidecutting Pliers	155 mm	EK1550B
Combination Pliers	170 mm	EA1700B
Tweezers	110 mm	EM1100B
Wire Stripping Pliers	155 mm	EL1550B
Adjustable End Wrench	19 mm, 150 mm	AT0150A
Screwdriver	3x150 mm	GF0315B
Screwdriver	4x120 mm	GF0412B
Screwdriver	5x200 mm	GF0520B
Phillips Screwdriver	PH 0	GK0006B
Phillips Screwdriver	PH 1	GK0008B
Ball End Driver	2 mm	CJ0020B
Ball End Driver	2.5 mm	CJ0025B
Ball End Driver	3 mm	CJ0030B
Ball End Driver	4 mm	CJ0040B
Ball End Driver	5 mm	CJ0050B
Common Knife	175 mm	JC0001B
Cutting Shears	150 mm	LA0075A

<b>RH</b>		
<b>HAZMAT - tool kit</b>		
HAZMAT - Werkzeugset		
HAZMAT - Jeu d'outils		
HAZMAT - Juego de herramientas		
Part No.	Parts	g
RH1051	18	9100
Content	Dimension	Part No.
Brush	4x16, 260 mm	KH0001
Crate Opener	230 mm	PV0230A
Claw Hammer	455 g	FK0020A
Knife	260 mm	JC0005B
Putty Knife	50 mm	JD0050B
Groove Joint Pliers	21/8", 300 mm	EC3000B
Long Nose Pliers	180 mm	EE1800B
Combination Pliers	200 mm	EA2000B
Deck Scraper	380 mm	JF0380A
Spray Booth Scraper	75 mm	JH0075A
Screwdriver	8x150 mm	GF0815B
Phillips Screwdriver	PH 3	GK3015B
Tin Snips	75x300 mm	LB0075A
Adjustable End Wrench	200 mm	AT0200A
Adjustable End Wrench	300 mm	AT0300A
Adjustable Pipe Wrench	350 mm	ET0350A
Bung Wrench	3/4x2"	CY2000A

<b>RM</b>		
<b>Machinist's tool kit</b>		
Montage - Werkzeugsatz		
Jeu d'outils de monteur		
Juego de herramientas de maquinista		
Part No.	Parts	g
RM1048	12	4650
Content	Dimension	Part No.
Combination pliers	4x16, 260 mm	KH0001
Brush	230 mm	PV0230A
Flitty knife	455 g	FK0020A
Knife	260 mm	JC0005B
Groove joint pliers	50 mm	JD0050B
Phillips screwdriver	21/8", 300 mm	EC3000B
Screwdriver	180 mm	EE1800B
Claw hammer	200 mm	EA2000B
Adjustable end wrench	380 mm	JF0380A
Adjustable end wrench	75 mm	JH0075A
Adjustable pipe wrench	8x150 mm	GF0815B
Part No.	Parts	g
RM1049	21	7000
Content	Dimension	Part No.
Combination Wrench	10 mm	AA0010A
Combination Wrench	11 mm	AA0011A
Combination Wrench	12 mm	AA0012A
Combination Wrench	13 mm	AA0013A
Combination Wrench	14 mm	AA0014A
Combination Wrench	17 mm	AA0017A
Combination Wrench	19 mm	AA0019A
Combination Wrench	22 mm	AA0022A
Phillips Screwdriver	PH 2	GK2010B
Screwdriver	8x150 mm	GF0815B
Adjustable End Wrench	250 mm	AT0250A
Combination Pliers	170 mm	EA1700B
Combination Pliers	200 mm	EA2000B
Groove Joint Pliers	250 mm	EC2500B
Knife	175 mm	JC0001B
Putty Knife	30 mm	JD0030B
Claw Hammer	455 g	FK0020A
Adjustable Pipe Wrench	350 mm	ET0350A
Brush	4x16, 260 mm	KH0001
Deck Scraper	300 mm	JF0300A





RN

**Marine kit**

Marine - werkzeugkasten  
Jeu d'outils - marine  
Juego - marino

Part No.	Parts	g
RN1050	30	75400
Content	Dimension	Part No.
Wrecking Bar	920 mm	MT0920A
Adjustable End Wrench	1.13/16", 250 mm	AT0250A
Adjustable End Wrench	1.3/8", 300 mm	AT0300A
Adjustable End Wrench	2", 375 mm	AT0380A
Ball Peen Hammer	1 lb	FD1002A
Ball Peen Hammer	2 lbs	FD1004A
Scaling Hammer	1 lb	FL0060A
Sledge Hammer	5 lbs	FG0070A
Deck Scraper	300 mm	JF0300A
Scraper	100 mm	JG0100A
Ship Scraper	100 mm	JL0100A
Screwdriver	10x200 mm	GF1020B
Screwdriver	10x300 mm	GF1030B
Scoop Shovel	330x430 mm	NS8000
Hand Chisel	17x155 mm	MA1155A
Hand Chisel	23x220 mm	MA0220A
Adjustable Pipe Wrench	1", 280 mm	ET1280A
Adjustable Pipe Wrench	1.1/2", 350 mm	ET1350A
Adjustable Pipe Wrench	2", 420 mm	ET1420A

RR

**Spray booth cleaning set**

Spritzkabinen - reinigungsset  
Jeu nettoyage pour cabine de peinture  
Juego herramientas para cabina de pintar

Part No.	Parts	g
RR1000	10	4600
Content	Dimension	Part No.
Putty Knife stiff	50 mm	JD0050B
Putty Knife stiff	90 mm	JD0090B
Putty Knife flexible	90 mm	JD1090B
Flat Scraper	20x200 mm	JA0200A
Pick Scraper	75x450 mm	JM0075A
Deck Scraper	50x300 mm	JF0300A
Spray Booth Scraper	75 mm	JH0075A
Scraper	100 mm	JG0100A
Brush	4x19, 350 mm	KH0001

RT

**Engineer's tool kit**

Techniker - Werkzeugsatz  
Jeu d'outils d'ingénieur  
Juego de herramientas de ingeniero

Part No.	Parts	g
RT1000	38	12700
Content	Dimension	Part No.
Combination Wrench	10 mm	AA0010A
Combination Wrench	11 mm	AA0011A
Combination Wrench	12 mm	AA0012A
Combination Wrench	13 mm	AA0013A
Combination Wrench	14 mm	AA0014A
Combination Wrench	15 mm	AA0015A
Combination Wrench	17 mm	AA0017A
Combination Wrench	19 mm	AA0019A
Combination Wrench	22 mm	AA0022A
Combination Wrench	24 mm	AA0024A
Double Box Wrench	6x7 mm	AC0607A
Double Box Wrench	8x9 mm	AC0809A
Double Box Wrench	10x11 mm	AC1011A
Double Box Wrench	12x13 mm	AC1213A
Double Box Wrench	14x17 mm	AC1417A
Double Box Wrench	19x22 mm	AC1922A
Allen Key Set	2, 3, 4, 5, 6, 8, 10 mm	CH1000B
Combination Pliers	200 mm	EA2000B
Diagonal Sidecutting Pliers	180 mm	EK1800B
Groove Joint Pliers	1.1/2", 250 mm	EC2500B
Swedish Pliers	1.1/2", 440 mm	ES3500B
Adjustable End Wrench	30 mm, 250 mm	AT0250A
Adjustable End Wrench	36 mm, 300 mm	AT0300A
GetmanQoss Peen Hammer	500 g	FS0500A
German Sledge Hammer	1000 g	FF0100A
Screwdriver	5x100 mm	GF0510B
Screwdriver	8x150 mm	GF0815B
Phillips Screwdriver	PH 1	GK1008B
Phillips Screwdriver	PH 3	GK3015B
Hand Chisel	20x200 mm	MA0200A
Cape Chisel	13x205 mm	MC0205A
Punch	5x120 mm	HA0512B
Punch	10x160 mm	HA1016B
Cutting Shears	200 mm	LA0110A
Knife	260 mm	JC0005B
Putty Knife	50 mm	JD0050B
Brush	4x16, 260 mm	KH0001

A series of horizontal dotted lines for writing notes, spanning the width of the page.



**SAFETY TOOLS®**

Protecting Lives

**SINCE 1922**

AC SAFETY TOOLS S.A.  
Route de Chésalles 48 • P.O. Box 45  
1723 Marly • SWITZERLAND  
Tel.: +41 26 439 93 00 • Fax: +41 26 439 93 01  
E-mail: [info@safetytools.com](mailto:info@safetytools.com)  
Website: [www.safetytools.com](http://www.safetytools.com)